

visual engineering
LIGHTWARE

User's Manual



HDMI-TPS-RX110AY
HDMI-TPS-RX110AY-Plus

HDBaseT™ Multimedia Extender

Important Safety Instructions

Class II apparatus construction.

The equipment should be operated only from the power source indicated on the product.

To disconnect the equipment safely from power, remove the power cord from the rear of the equipment, or from the power source. The MAINS plug is used as the disconnect device, the disconnect device shall remain readily operable.

There are no user-serviceable parts inside of the unit. Removal of the cover will expose dangerous voltages. To avoid personal injury, do not remove the cover. Do not operate the unit without the cover installed.

The appliance must be safely connected to multimedia systems. Follow instructions described in this manual.

Ventilation

For the correct ventilation and to avoid overheating ensure enough free space around the appliance. Do not cover the appliance, let the ventilation holes free and never block or bypass the ventilators (if any).

WARNING

To prevent injury, the apparatus is recommended to securely attach to the floor/wall or mount in accordance with the installation instructions. The apparatus shall not be exposed to dripping or splashing and that no objects filled with liquids, such as vases, shall be placed on the apparatus. No naked flame sources, such as lighted candles, should be placed on the apparatus.

Waste Electrical & Electronic Equipment WEEE

This marking shown on the product or its literature, indicates that it should not be disposed with other household wastes at the end of its working life. To prevent possible harm to the environment or human health from uncontrolled waste disposal, please separate this from other types of wastes and recycle it responsibly to promote the sustainable reuse of material resources. Household users should contact either the retailer where they purchased this product, or their local government office, for details of where and how they can take this item for environmentally safe recycling. Business users should contact their supplier and check the terms and conditions of the purchase contract. This product should not be mixed with other commercial wastes for disposal.

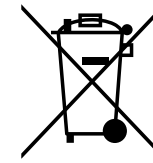

Common Safety Symbols

Symbol	Description
	Direct current
	Alternating current
	Double insulation
	Caution, possibility of electric shock
	Caution

Symbol Legend

The following symbols and markings are used in the document:

WARNING! Safety-related information which is highly recommended to read and keep in every case!

ATTENTION! Useful information to perform a successful procedure; it is recommended to read.

DIFFERENCE: Feature or function that is available with a specific firmware/hardware version or product variant.

INFO: A notice which may contain additional information. Procedure can be successful without reading it.

DEFINITION: The short description of a feature or a function.

TIPS AND TRICKS: Ideas which you may have not known yet but can be useful.

Navigation Buttons

 Go back to the previous page. If you clicked on a link previously, you can go back to the source page by clicking the button.

 Navigate to the Table of Contents.

 Step back one page.

 Step forward to the next page.

Document Information

This User's Manual applies to the following versions of the mentioned software, firmware, and hardware:

Item	Version
Lightware Device Controller (LDC) software	1.33.0b5
Lightware Device Updater V2 (LDU2) software	2.0.0b22
Controller firmware	1.3.1
Hardware	1.2

Document revision: **2.3**

Release date: 08-10-2019

Editor: Tamas Forgacs

About Printing

Lightware Visual Engineering supports green technologies and eco-friendly mentality. Thus, this document is made for digital usage primarily. If you need to print out few pages for any reason, follow the recommended printing settings:

- Page size: A4
- Output size: Fit to page or Match page size
- Orientation: Landscape

TIPS AND TRICKS: Thanks to the size of the original page, a border around the content (grey on the second picture below) makes possible to organize the pages better. After punching the printed pages, they can be placed easily into a ring folder.

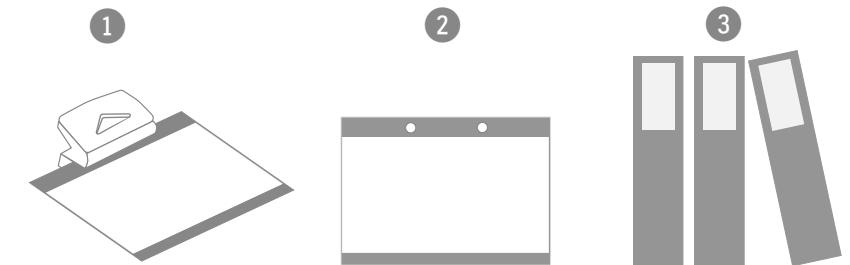

Hashtag (#) Keywords in the Document

This user's manual contains keywords with hashtag (#) to help you to find the relevant information as quick as possible.

The format of the keywords is the following:

#<keyword>_<chapter>

The usage of the keywords: use the **Search** function (Ctrl+F / Cmd+F) of your PDF reader application, type the # (hashtag) character and the wished keyword.

The **#new** special keyword indicates a new feature/function that has just appeared in the latest firmware or software version.

Example

#dhcp_lw3

This keyword is placed at the DHCP setting command in the LW3 Programmer's reference section.

Table of Contents

1. INTRODUCTION	7	3.10. FURTHER BUILT-IN FEATURES	20	5.9.1. Status	39
1.1. DESCRIPTION.....	7	3.10.1. Automatically Launched Actions – The Event Manager.....	20	5.9.2. Network.....	40
1.2. COMPATIBLE DEVICES	7	3.10.2. Receiver Cloning – Configuration Backup and Restore	20	5.9.3. Front Panel.....	40
1.3. BOX CONTENTS	7	3.10.3. Remote Firmware Upgrade of Connected Lightware Devices...	20	5.9.4. Backup	40
1.4. FEATURES	8	4. OPERATION	21	5.9.5. System	41
1.5. MODEL COMPARISON	8	4.1. FRONT PANEL - SPECIAL FUNCTIONS	21	5.10. CONFIGURATION CLONING (BACKUP TAB)	41
1.6. TYPICAL APPLICATION	9	4.1.1. Programmable Function Button	21	5.10.1. Cloning Steps in a Nutshell.....	41
2. INSTALLATION	10	4.1.2. Enable Dynamic (DHCP) IP Address	21	5.10.2. Save the Settings of the Device (Backup).....	42
2.1. MOUNTING OPTIONS	10	4.1.3. Reset to Factory Default Settings.....	21	5.10.3. Upload the Settings to a Device (Restore).....	42
2.1.1. 1U High Rack Shelf.....	10	4.1.4. Resetting the Device.....	21	5.10.4. Create and Restore Backups from the Device Memory.....	42
2.1.2. Under-desk Double Mounting Kit.....	10	4.1.5. Entering Bootload Mode	21	5.11. ADVANCED VIEW WINDOW	43
2.2. CONNECTING STEPS	11	4.2. SOFTWARE CONTROL MODES	22	6. LW2 PROGRAMMERS' REFERENCE	44
3. PRODUCT OVERVIEW	12	5. SOFTWARE CONTROL - LIGHTWARE DEVICE CONTROLLER	23	6.1. LW2 PROTOCOL DESCRIPTION	44
3.1. FRONT VIEW.....	12	5.1. INSTALL AND UPGRADE	23	6.2. GENERAL LW2 COMMANDS	44
3.2. REAR VIEW.....	13	5.2. RUNNING THE LDC	23	6.2.1. View Product Type.....	44
3.3. ELECTRICAL CONNECTIONS	13	5.3. ESTABLISHING THE CONNECTION	24	6.2.2. Query Control Protocol.....	44
3.3.1. DC 12V Connection	13	5.4. PORT PARAMETERS MENU	25	6.2.3. View Firmware Version of the CPU	45
3.3.2. HDMI Connector	13	5.4.1. Video Tab	25	6.2.4. Connection Test.....	45
3.3.3. Analog Audio Output.....	13	5.4.2. CEC Command Sending.....	26	6.2.5. View Serial Number	45
3.3.4. Ethernet Connector (TPS and LAN Ports)	14	5.4.3. Audio Tab	27	6.2.6. Compile Time.....	45
3.3.5. USB Connector.....	14	5.5. DIAGNOSTIC TOOLS	28	6.2.7. View Installed Board.....	45
3.3.6. IR Connector	14	5.5.1. Frame Detector	28	6.2.8. View Firmware for All Controllers.....	45
3.3.7. RS-232 Connector.....	14	5.5.2. Cable Diagnostics.....	28	6.2.9. Restart the Device	45
3.3.8. Relay Connector.....	14	5.6. EDID MENU	29	6.2.10. Query Health Status	45
3.4. TPS RECEIVER CONCEPT	14	5.6.1. EDID Operations.....	29	6.2.11. Restore Factory Default Settings.....	45
3.5. PORT DIAGRAM	15	5.6.2. EDID Summary Window	30	6.3. PORT SETTINGS	46
3.6. TPS INTERFACE	15	5.6.3. Editing an EDID	30	6.3.1. Mute Output	46
3.7. AUDIO INTERFACE	15	5.6.4. Creating an EDID - Easy EDID Creator	31	6.3.2. Unmute Output	46
3.7.1. Audio Input.....	15	5.7. CONTROL MENU	31	6.3.3. Lock Output.....	46
3.7.2. Audio Output Modes	15	5.7.1. RS-232.....	31	6.3.4. Unlock Output	46
3.7.3. Audio Options - Example.....	16	5.7.2. Relays.....	33	6.3.5. View Connection State on The Output	46
3.8. VIDEO INTERFACE	16	5.7.3. Ethernet.....	33	6.3.6. View Crosspoint Size.....	46
3.9. CONTROL FEATURES	16	5.7.4. Infra	34	6.4. NETWORK CONFIGURATION	47
3.9.1. Serial Interface.....	17	5.8. EVENT MANAGER	36	6.4.1. Query the Current IP Status	47
3.9.2. RS-232 Recognizer	18	5.8.1. The Event Editor.....	37	6.4.2. Set the IP Address	47
3.9.3. IR Interface.....	18	5.8.2. Create or Modify an Event.....	37	6.4.3. Set the Subnet Mask	47
3.9.4. Relay Interface.....	19	5.8.3. Special Tools and Accessories.....	38	6.4.4. Set the Gateway Address.....	47
3.9.5. Consuming Electronic Control (CEC) Interface	20	5.8.4. Clear One or More Event(s).....	38	6.4.5. Apply Network Settings.....	47
3.9.6. USB Control Interface.....	20	5.8.5. Export and Import Events	38	6.5. RS-232 SETTINGS	48
3.9.7. Ethernet Control Interface.....	20	5.8.6. Event Creating - Example	38	6.5.1. Set RS-232 Mode	48
		5.9. SETTINGS MENU	39	6.5.2. Set Local RS-232 Parameters.....	48
				6.5.3. Set Link RS-232 Parameters	48

Table of Contents

6.5.4. Set Local RS-232 Control Protocol Port.....	48	7.4.15. Test Pattern Setting.....	58	7.9.1. Enable the Recognizer.....	67
6.5.5. Set Link RS-232 Control Protocol Port.....	48	7.4.16. HDMI Mode Settings (Output Port).....	59	7.9.2. Set the Delimiter Hex.....	67
6.6. RELAY SETTINGS	49	7.4.17. Query the Recent TPS Mode.....	59	7.9.3. Set the Timeout	67
6.6.1. Query Relay Connection State	49	7.4.18. TPS Mode Settings.....	59	7.9.4. Query the Last Recognized Serial Message in String Format	67
6.6.2. Set Relay Connection State.....	49	7.5. AUDIO PORT SETTINGS.....	60	7.9.5. Query the Last Recognized Serial Message in Hex Format.....	67
6.7. LW2 COMMANDS – QUICK SUMMARY	50	7.5.1. Query the Status of Source Ports	60	7.9.6. Query the Last Recognized Serial Message in Hash Format	67
7. LW3 PROGRAMMERS' REFERENCE.....	51	7.5.2. Query the Status of Destination Port	61	7.9.7. Clear the Stored Last Recognized Serial Message	68
7.1. OVERVIEW.....	51	7.5.3. Mute Input.....	61	7.9.8. Query the Last Recognized Serial Message in String Format	68
7.2. PROTOCOL RULES.....	51	7.5.4. Unmute Input	61	7.9.9. Query the Last Recognized Serial Message in Hex Format.....	68
7.2.1. LW3 Tree Structure and Command Structure (examples).....	51	7.5.5. Lock Input	61	7.9.10. Query the Last Recognized Serial Message in Hash Format	68
7.2.2. General Rules.....	51	7.5.6. Unlock Input.....	61	7.9.11. Set the Active Timeout.....	68
7.2.3. Command Types.....	52	7.5.7. Mute Output.....	61	7.10. INFRARED PORT CONFIGURATION	68
7.2.4. Prefix Summary	52	7.5.8. Unmute Output	61	7.10.1. Enable Command Injection Mode.....	68
7.2.5. Error Messages.....	52	7.5.9. Lock Output.....	62	7.10.2. Change Command Injection Port Number	69
7.2.6. Escaping.....	52	7.5.10. Unlock Output.....	62	7.10.3. Enable/Disable Output Signal Modulation.....	69
7.2.7. Signature.....	53	7.6. ANALOG AUDIO OUTPUT SETTINGS.....	62	7.11. SENDING MESSAGE VIA THE COMMUNICATION PORTS	69
7.2.8. Subscription.....	53	7.6.1. Volume Setting (dB)	62	7.11.1. Sending a TCP Message (ASCII-format) via TCP Port.....	69
7.2.9. Notifications about the Changes of the Properties	53	7.6.2. Volume Setting (dB) in Steps.....	62	7.11.2. Sending a TCP Text (ASCII-format) via TCP Port	69
7.2.10. Legend for the Control Commands.....	53	7.6.3. Volume Setting (Percent).....	62	7.11.3. Sending a TCP Binary Message (HEX-format) via TCP Port	70
7.3. SYSTEM COMMANDS.....	54	7.6.4. Volume Setting (Percent) in Steps	62	7.11.4. Sending UDP Message (ASCII-format) via TCP Port	70
7.3.1. Query the Product Name.....	54	7.6.5. Balance Setting.....	63	7.11.5. Sending a TCP Text (ASCII-format) via TCP Port	70
7.3.2. Set the Device Label.....	54	7.6.6. Balance Setting in Steps.....	63	7.11.6. Sending a UDP Binary Message (HEX-format) via TCP Port	70
7.3.3. Query the Serial Number.....	54	7.7. NETWORK CONFIGURATION	63	7.11.7. Sending a Message (ASCII-format) via Serial Port	70
7.3.4. Query the Firmware Version	54	7.7.1. Query the DHCP State	63	7.11.8. Sending a Text (ASCII-format) via Serial Port.....	71
7.3.5. Identify the Device	54	7.7.2. Change the DHCP State.....	63	7.11.9. Sending a Binary Message (HEX-format) via Serial Port.....	71
7.3.6. Dark Mode.....	54	7.7.3. Query the IP Address.....	63	7.11.10. Using Hexadecimal Codes.....	71
7.3.7. Restarting the Device	55	7.7.4. Change the IP Address (Static)	64	7.11.11. Sending Pronto Hex Codes in Little-endian Format via IR Port.....	71
7.3.8. Restore the Factory Default Settings	55	7.7.5. Query the Subnet Mask.....	64	7.11.12. Sending Pronto Hex Codes in Big-endian Format via IR Port.....	72
7.4. VIDEO PORT SETTINGS	55	7.7.6. Change the Subnet Mask (Static).....	64	7.12. SENDING CEC COMMANDS.....	72
7.4.1. Query the Status of Source Ports.....	55	7.7.7. Query the Gateway Address	64	7.12.1. Sending an OSD String.....	72
7.4.2. Query the Status of Destination Port	56	7.7.8. Change the Gateway Address (Static).....	64	7.12.2. Sending a CEC Command in Text Format.....	73
7.4.3. Mute Input.....	56	7.7.9. Query the MAC Address.....	64	7.12.3. Sending a CEC Command in Hexadecimal Format.....	73
7.4.4. Unmute Input	56	7.7.10. Apply Network Settings.....	64	7.13. RELAY PORT SETTINGS.....	73
7.4.5. Lock Input	57	7.8. RS-232 PORT CONFIGURATION	65	7.13.1. Query the Connection State.....	73
7.4.6. Unlock Input.....	57	7.8.1. Protocol Setting.....	65	7.13.2. Change the Connection State.....	73
7.4.7. Mute Output.....	57	7.8.2. BAUD Rate Setting.....	65	7.13.3. Toggle the Connection State	73
7.4.8. Unmute Output	57	7.8.3. Databits Setting.....	65	7.14. EDID MANAGEMENT.....	74
7.4.9. Lock Output.....	57	7.8.4. Stopbits Setting	65	7.14.1. Query the Emulated EDIDs.....	74
7.4.10. Unlock Output.....	57	7.8.5. Parity Setting.....	66	7.14.2. Query the Validity of a Dynamic EDID	74
7.4.11. HDCP Setting (Input Port).....	57	7.8.6. RS-232 Operation Mode.....	66	7.14.3. Query the Preferred Resolution of an User EDID	74
7.4.12. HDCP Setting (Output Port).....	58	7.8.7. Query the Command Injection Mode	66	7.14.4. Emulating an EDID to an Input Port.....	74
7.4.13. Test Pattern Generator Mode	58	7.8.8. Change the Command Injection Mode	66	7.14.5. Emulating an EDID to All Input Ports.....	74
7.4.14. Test Pattern Generator Clock Source.....	58	7.9. RS-232 RECOGNIZER	67	7.14.6. Copy an EDID to User Memory	74

Table of Contents

7.14.7. Deleting an EDID from User Memory	75
7.14.8. Resetting the Emulated EDIDs.....	75
7.15. LW3 COMMANDS - QUICK SUMMARY	76
8. FIRMWARE UPGRADE	80
8.1. ABOUT THE FIRMWARE PACKAGE (LFP2 FILE).....	80
8.2. SHORT INSTRUCTIONS.....	80
8.3. INSTALLATION OF LDU2	80
8.4. DETAILED INSTRUCTIONS.....	80
8.4.1. Establish Connection	80
8.4.2. Start the LDU2 Application and Follow the Steps	80
8.5. KEEPING THE CONFIGURATION SETTINGS	83
8.6. REMOTE FIRMWARE UPGRADE OF CONNECTED LIGHTWARE DEVICES ...	84
9. TROUBLESHOOTING	85
9.1. USE CASE STUDIES	85
9.2. HOW TO SPEED UP THE TROUBLESHOOTING PROCESS	87
10. TECHNOLOGIES.....	88
10.1. EDID MANAGEMENT.....	88
10.1.1. Understanding the EDID.....	88
10.1.2. Advanced EDID Management.....	88
10.2. HDCP MANAGEMENT	89
10.2.1. Protected and Unprotected Content	89
10.2.2. Disable Unnecessary Encryption.....	89
10.3. PIXEL ACCURATE RECLOCKING	90
11. APPENDIX	91
11.1. SPECIFICATION	91
11.2. INPUT/OUTPUT PORT NUMBERING.....	92
11.3. CONTENT OF BACKUP FILE.....	92
11.4. FACTORY DEFAULT SETTINGS.....	92
11.5. MAXIMUM EXTENSION DISTANCES.....	93
11.6. MECHANICAL DRAWINGS	93
11.7. CABLE WIRING GUIDE	94
11.7.1. Cable Wiring Guide for Serial Data Transmission	94
11.7.2. Audio Cable Wiring Guide	94
11.8. FACTORY EDID LIST	95
11.9. RELEASE NOTES OF THE FIRMWARE PACKAGES	96
11.10. FURTHER INFORMATION.....	97

1

Introduction

Thank you for choosing Lightware's HDMI-TPS-RX110AY series receiver. In the first chapter we would like to introduce the device highlighting the most important features in the below listed sections:

- ▶ DESCRIPTION
- ▶ COMPATIBLE DEVICES
- ▶ BOX CONTENTS
- ▶ FEATURES
- ▶ MODEL COMPARISON
- ▶ TYPICAL APPLICATION

1.1. Description

A small size HDBaseT™ TPS receiver unit is being developed in the Lightware works with one PoE capable TPS input and a single HDMI output. The unit is full 4K/UHD and 3D capable and HDCP compliant. The HDMI audio is de-embedded to the balanced audio output via a Phoenix (Euroblock) connector, the audio port has volume and balance control. The built-in Event Manager feature and the dual Relay module of the device are both configurable via the Lightware Device Controller software. Further control options are served by the USB, RS-232, IR (in and out), and Ethernet ports.

Model Denomination

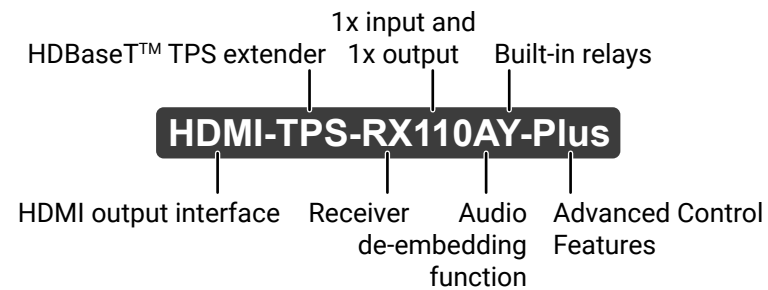

1.2. Compatible Devices

The receiver is compatible with other Lightware TPS transmitters, matrix TPS and TPS2 boards, 25G TPS2 boards, as well as third-party HDBaseT-extenders, displays, but not compatible with the phased out TPS-90 extenders.

ATTENTION! The receiver is PoE-compatible (Power over Ethernet, can be powered remotely via using CATx cable) but the device can only receive power and cannot send power other PoE-compatible devices. Only the TPS connector is PoE-compatible, Ethernet port cannot receive power.









The receiver is compatible with any third-party HDBaseT™ device.

HDBaseT™ and the HDBaseT Alliance logo are trademarks of the HDBaseT Alliance.

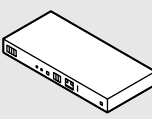
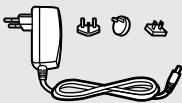
The List of Compatible Lightware Devices

- MX Modular matrix frames - MX-TPS/TPS2-OB
- 25G Modular matrix frames - 25G-TPS2-OB
- Standalone TPS matrix frames – MMX6x2-HT series
- TPS transmitters:
 - HDMI-TPS-TX95/96/97
 - DVI-HDCP-TPS-TX95/96/97
 - UMX-TPS-TX100 series
 - WP-UMX-TPS-TX100 series
 - SW4-TPS-TX240
 - HDMI-TPS-TX200 series
 - DVI-HDCP-TPS-TX200 series
 - DP-TPS-TX200 series
- Single port standalone TPS power injector – TPS-PI-1P1

1.3. Box Contents

 HDMI-TPS-RX110AY receiver	 12V DC adaptor with interchangeable plugs	 Phoenix® Combicon 3-pole connector
 Phoenix® Combicon 4-pole connector	 Phoenix® Combicon 5-pole connector	 Infrared detector unit
 Infrared emitter unit	 Safety & warranty info, Quick Start Guide	

1.4. Features



3D and 4K Support

High bandwidth allows extension of resolutions up to 4K and even 3D sources and displays are supported.



Signal Transmission up to 170 m

Video and audio signal transmission (HDMI, Ethernet, RS-232, and Infra-Red over a single CAT5e...CAT7e cable).



Pixel Accurate Reclocking

Each output has a clean, jitter free signal, eliminating signal instability and distortion caused by long cables or connector reflections.



Frame Detector and Signal Analysis

The exact video and audio signal format can be determined such as timing, frequencies, scan mode, HDCP encryption, color range, color space and audio sample rate.



HDCP-compliant

The receiver fulfills the HDCP standard. HDCP capability on the digital video inputs can be disabled when non-protected content is extended.



Built-in Event Manager

The Event Manager tool takes care of all the necessary control in a smaller configuration by performing predefined actions in response to device status changes. Hence, in a less complex environment, there is no need to invest in additional control solutions, which makes the receiver the best choice for numerous applications.



Remote Power

The receiver is PoE-compatible and can be powered locally by the supplied power adaptor, or remotely via the TPS connection (through the CATx cable) with a compatible power source equipment, e.g. MMX6x2-HT series matrix switchers and TPS2 matrix boards.



Bi-directional RS-232 Pass-through

AV systems can also contain serial port controllers and controlled devices. Serial port pass-through supports any unit that works with standard RS-232.



Relay

2x controllable relay modules up to 30V, 1A support.



Ethernet Control

Multiple simultaneous TCP/IP connections are available with a simple ASCII-based protocol for controlling, configuring the receiver or perform a firmware upgrade.



Dark Mode

Rental application requires this function, which keeps the LEDs unlit to hide the device during the event. *#new*

Advanced Control Features (Only for the Plus series)



Consumer Electronic Control

Supports transmitting standard CEC commands in order to remote control the source or sink device. *#new*



Infra Message Sending

Infrared (IR) is a wireless technology used for device communication over short ranges. Third party control systems may send IR control commands to endpoints turning them on and off or switching their inputs. *#new*





RS-232 Recognizer

Support recognizing incoming RS-232 messages to integrate with 3rd party devices like VC codec. *#new*

1.5. Model Comparison

The available models have different features depending on their design. The following table contains the most important differences between the two models:

	Advanced control features		
	Infra message sending 	CEC message sending 	RS-232 recognizer 
HDMI-TPS-RX110AY	-	-	-
HDMI-TPS-RX110AY-Plus	✓	✓	✓

The AV input/output ports, interface ports and the software features which are not mentioned here are the same in case of both models.

1.6. Typical Application

Standalone Application Diagram

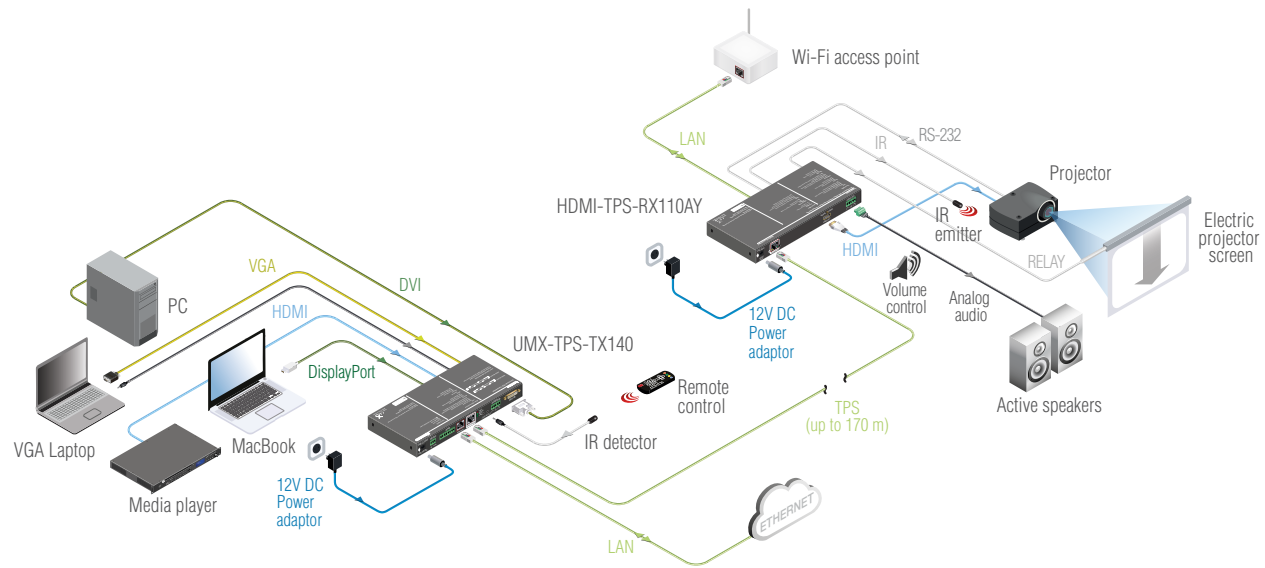

Integrated System Diagram

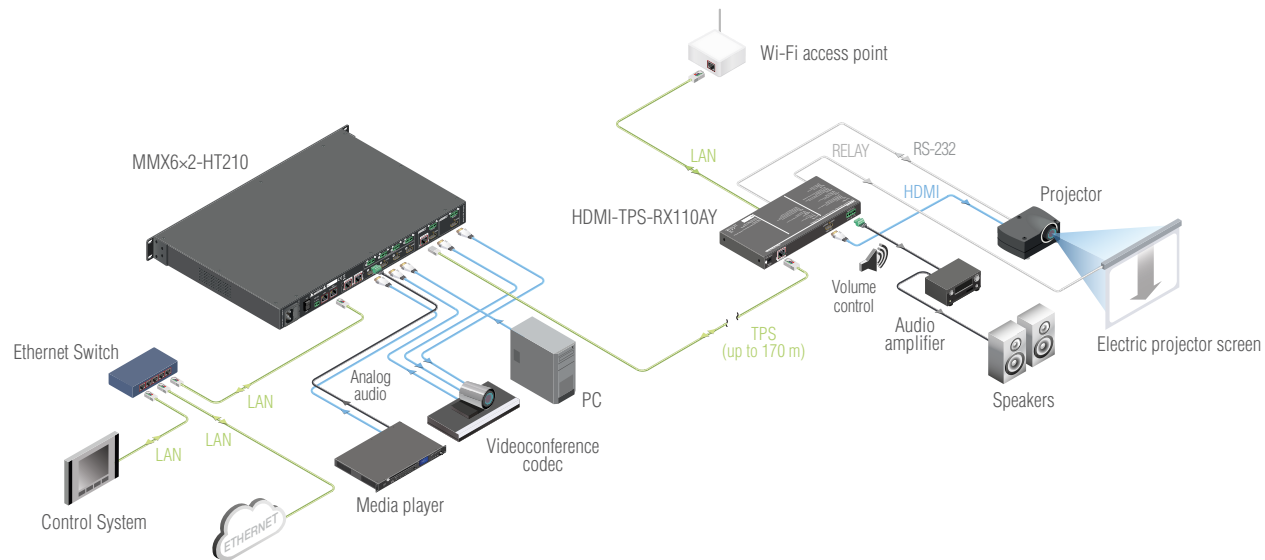

2

Installation

The chapter is about the installation of the device and connecting to other appliances, presenting also the mounting options and further assembly steps:

- ▶ [MOUNTING OPTIONS](#)
- ▶ [CONNECTING STEPS](#)

2.1. Mounting Options

To mount the receiver Lightware supplies optional accessories for different usage. There are two kinds of mounting kits with similar fixing method. The receiver has two mounting holes with inner thread on the bottom side; see the bottom view in the [Mechanical Drawings](#) section. Fasten the device by the screws enclosed to the accessory:

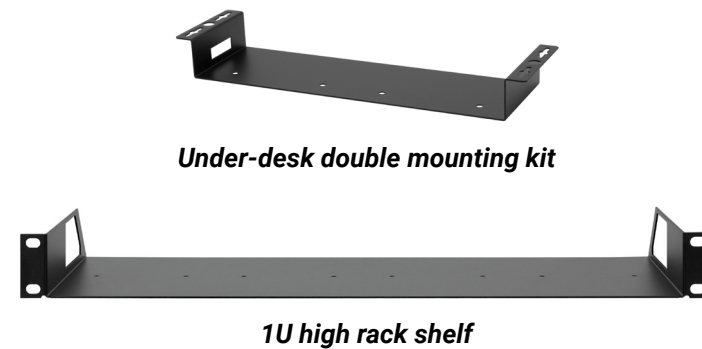

The Under-desk double mounting kit makes easy to mount a single device on any flat surface, e.g. furniture. 1U high rack shelf provides mounting holes for fastening two half-rack or four quarter-rack sized units. Pocket-sized devices can also be fastened on the shelf. To order mounting accessories please contact sales@lightware.com.

WARNING! Always use the supplied screws. Using different (e.g. longer) ones may cause damage to the device.

INFO: The receiver is half-rack sized.

2.1.1. 1U High Rack Shelf

Allows rack mounting for half-rack, quarter-rack and pocket sized units.

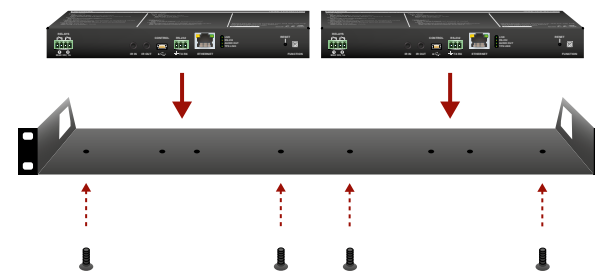

1U high rack shelf provides mounting holes for fastening two half-rack or four quarter-rack sized units. Pocket sized devices can also be fastened on the self.

2.1.2. Under-desk Double Mounting Kit

The UD-kit double makes it easy to mount a single receiver on any flat surface (e.g. furniture).

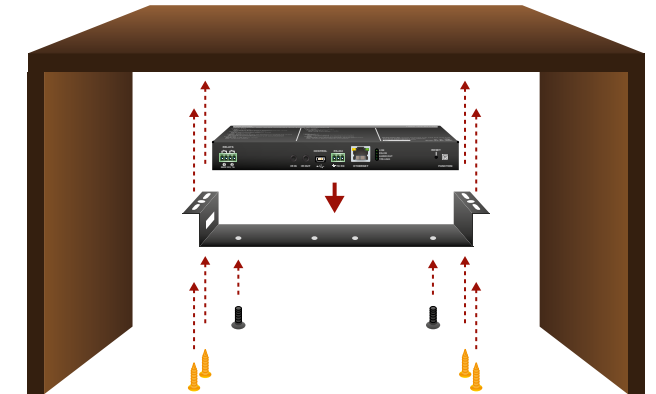

INFO: The chipboard screws are not supplied with the mounting kit.

2.2. Connecting Steps

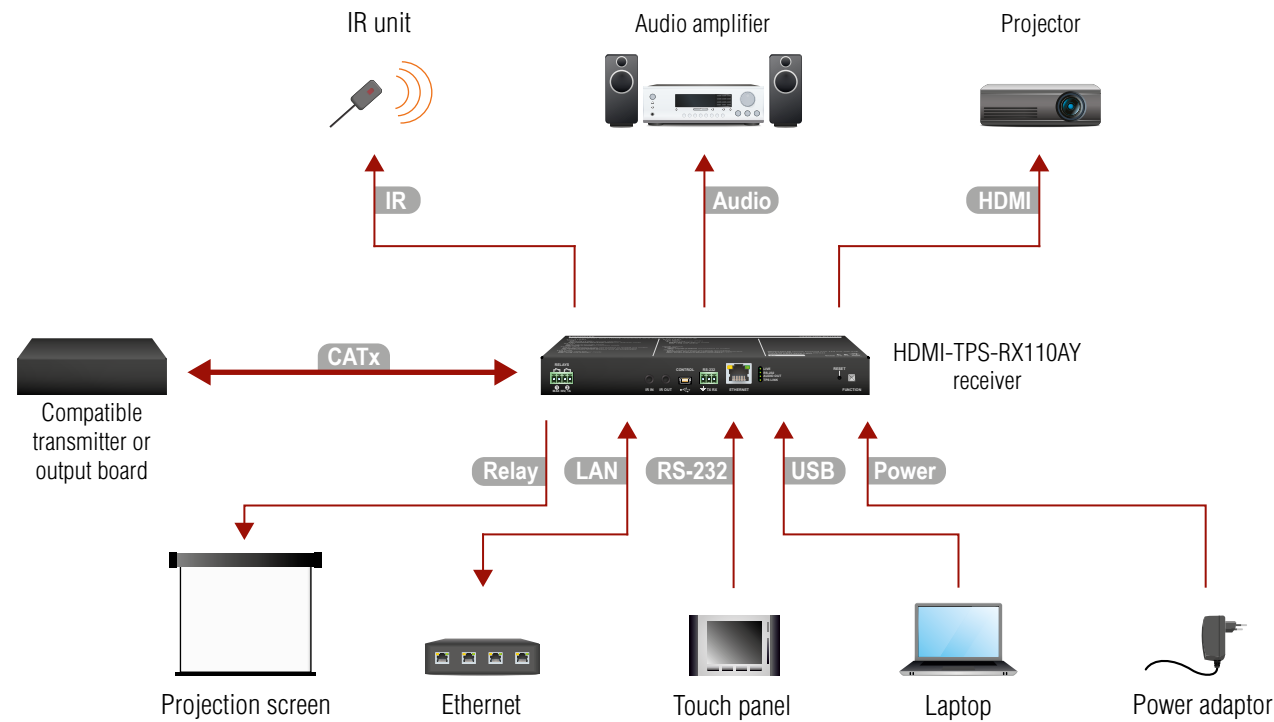

CATx Connect the compatible transmitter or the matrix output board and the receiver unit by a CATx cable via the TPS connectors.

HDMI Connect the sink device to the HDMI output port.

Audio Optionally connect an audio device (e.g. an audio amplifier) to the audio output port. See the wiring guide for the Phoenix 5-pole connector in the [Cable Wiring Guide](#) section.

IR Optionally for Infrared extension:
 - Connect the IR emitter to the IR OUT port of the receiver.
 - Connect the IR detector to the IR IN port of the receiver.

USB Optionally connect the receiver to a control device (e.g. laptop) with an USB mini cable.

RS-232 Optionally for RS-232 extension: connect a controller/controlled device (e.g. touch panel) to the RS-232 port.

LAN Optionally connect the receiver to a LAN network in order to control the device.

Relay Optionally for relays: connect a controlled device(s) (e.g. a projection screen) to the relay port.

Power See powering options on the next section.

Powering Options

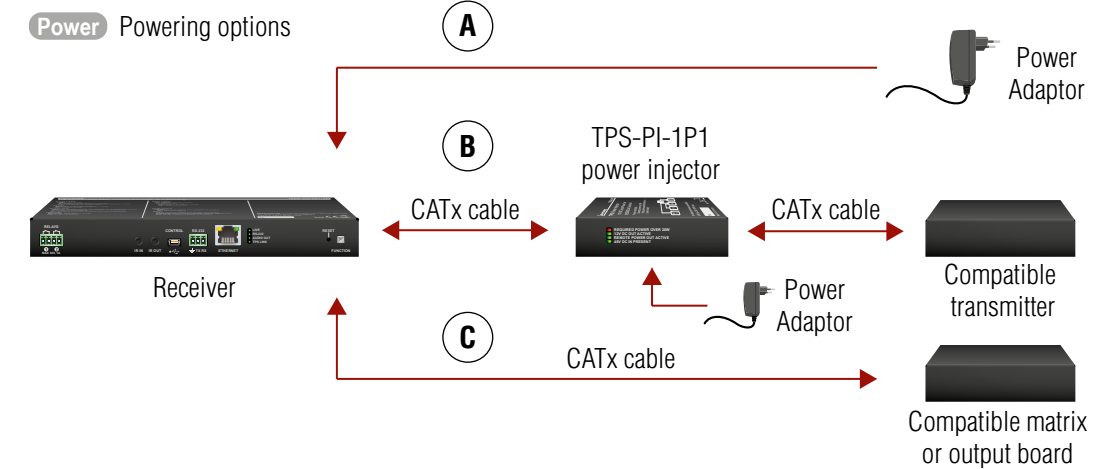

A **Using local PSU** - connect the power adaptor to the DC input on the receiver first, then to the AC power socket.

B **Using PoE with connecting a transmitter:** connect the TPS IN (PoE) port of the receiver to the TPS+PoE output port of the TPS-PI-1P1 power injector by a CATx cable as well as connect the TPS output port of the transmitter to the TPS port of the TPS-PI-1P1 by a CATx cable.

C **Using PoE with connecting a matrix or an output board:** connect the TPS IN (PoE) port of the receiver to the PoE-compatible TPS output port of the matrix or output board by a CATx cable.

ATTENTION! In case of connecting the receiver to an output board of the matrix always connect an external PSU to the board. For the detailed information please read the user's manual of the matrix.

ATTENTION! The Ethernet port does not support PoE. Only the TPS port support PoE function.

INFO: If both remote and local power sources are connected, the remote power will be used.

3

Product Overview

The following sections are about the physical structure of the device, input/output ports and connectors:

- ▶ [FRONT VIEW](#)
- ▶ [REAR VIEW](#)
- ▶ [ELECTRICAL CONNECTIONS](#)
- ▶ [TPS RECEIVER CONCEPT](#)
- ▶ [PORT DIAGRAM](#)
- ▶ [TPS INTERFACE](#)
- ▶ [AUDIO INTERFACE](#)
- ▶ [VIDEO INTERFACE](#)
- ▶ [CONTROL FEATURES](#)
- ▶ [FURTHER BUILT-IN FEATURES](#)

3.1. Front View

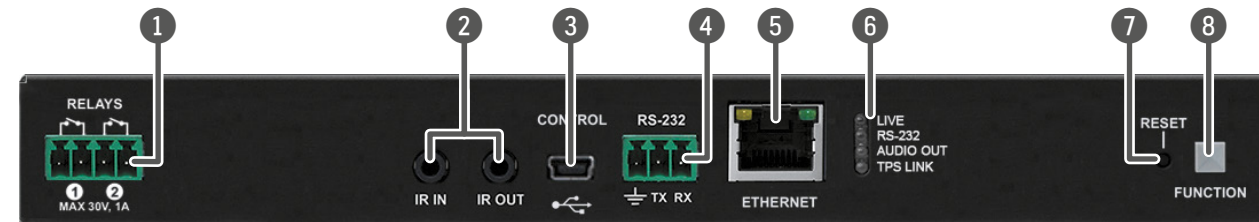

- 1 **Relay** 4-pole Phoenix connector for relay ports. Pin assignment can be found in the [Relay Connector](#) section.
- 2 **IR IN and OUT** 3-pole TRS connector, also known as 3.5 mm (1/8") jack plug for optional IR receiver (IR IN) and transmitter (IR OUT). Pin assignments can be found in the [IR Connector](#) section.
- 3 **USB** USB interface for LDC connection to control the receiver.
- 4 **RS-232** 3-pole Phoenix connector for controlling the device with LDC or third-party control systems. Pin assignment can be found in the [RS-232 Connector](#) section.
- 5 **Ethernet** Locking RJ45 connector for controlling the device with LDC or third-party control systems and LDU for firmware upgrade.
- 6 **Status LEDs** The LEDs give immediate feedback about current state of the device. See below the details.
- 7 **Reset button** Pressing reset button reboots the extender.
- 8 **Function button** Special functions are available with this button (switch to bootload mode, enable DHCP, restore factory default settings). For the details about special functions see the [Front Panel - Special Functions](#) section.

INFO: The illumination of the status LEDs can be switched off (dark mode) in the LDC software (see the details in the [Front Panel](#) section) and using LW3 protocol command (see the details in the [Dark Mode](#) section).

Status LEDs

LIVE



- OFF:** The device is not powered.
- BLINKING:** (slow; 1 sec): Device is powered and operational.
(fast; 0,5 sec): Device is in bootload mode.
- ON:** The device is powered but not operational.

RS-232



- OFF:** RS-232 ports (local and link) in Pass-through mode.
- BLINKING:** Command Injection mode is active.
- ON:** RS-232 ports (local and link) are in Control mode.

AUDIO OUT



- OFF:** Embedded audio is not present or analog output is muted.
- BLINKING:** Embedded audio format is not supported for audio de-embedding.
- ON:** Embedded audio is present and de-embedded.

TPS LINK



- OFF:** No TPS link between transmitter and receiver.
- BLINKING:** Device is in low power mode or in Ethernet fallback mode.
- ON:** TPS link is established, HDBaseT or Long Reach mode is active.

3.2. Rear View



- 1 **DC 12V IN** Local power in; connect the output of the supplied 12V DC power adaptor. For more details see next section.
- 2 **TPS IN (PoE)** Locking RJ45 connector. Connect a twisted pair cable between the transmitter and the receiver. Remote powering is also available through this connector. Maximum CATx cable distances can be found in the [Maximum Extension Distances](#) section.
- 3 **SIGNAL status LED** The LED gives immediate feedback about current state of the HDMI output signal. See the legend below.
- 4 **HDMI OUT** Connect an HDMI cable between the receiver and the local sink device. Applied cable shall not be more, than 30 m (when the signal is 1080p) and 20 m (when the signal is 4K).
- 5 **HDCP status LED** The LED gives immediate feedback about current state of HDCP. See the legend next to the table.
- 6 **AUDIO OUT** 5-pole Phoenix connector for asymmetric analog audio output. Pin assignment can be found in the next section.

TPS Input LEDs

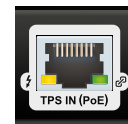

OFF: Remote power (PoE) is inactive, device is powered locally.

ON: Remote power is active.



OFF: No TPS link between the transmitter and receiver.

BLINKING: Device is in low power mode or Ethernet fallback mode.

ON: TPS signal is present.

SIGNAL LED for HDMI Output



OFF: Output signal is not present or muted.

ON: Signal is present.

HDCP LED for HDMI Output



OFF: Output signal is not HDCP-encrypted.

BLINKING: Non-HDCP capable device is connected, encrypted signal is replaced with red screen.

ON: Output signal is HDCP-encrypted.

3.3. Electrical Connections

3.3.1. DC 12V Connection

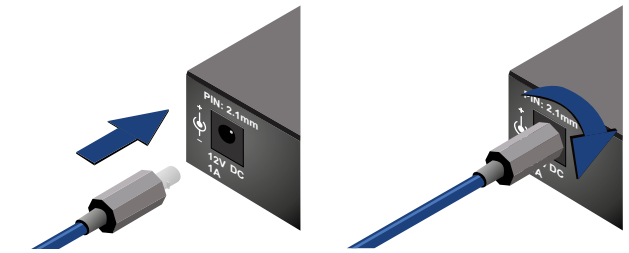

Locking DC connector

Do not forget to turn the plug clockwise direction before disconnecting the power adaptor.

WARNING! Always use the supplied 12V power adaptor. Warranty void if damage occurs due to use of a different power source.

3.3.2. HDMI Connector

The extender provides standard 19 pole HDMI connector for output. Always use high quality HDMI cable for connecting sources and displays. 

3.3.3. Analog Audio Output

5-pole Phoenix connector is used for balanced analog audio output. Unbalanced audio signals can be connected as well. For unbalanced output connect + and ground to the source and connect - to the ground.



Pin nr.	Signal
1	Left+
2	Left-
3	Ground
4	Right-
5	Right+

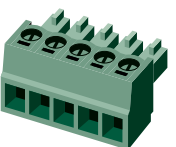

Analog audio connector and plug pin assignments

Compatible Plug Type

Phoenix® Combicon series (3.5mm pitch, 5-pole), type: MC 1.5/5-ST-3.5.

You can find more information about analog audio function in the [Audio Interface](#) section. Audio cable wiring guide is in the [Cable Wiring Guide](#) section.

3.3.4. Ethernet Connector (TPS and LAN Ports)

The extender provides standard RJ45 connectors for TPS IN and LAN ports. Always use high quality Ethernet cable for connecting transmitters and receivers. Maximum CATx cable distances can be found in the [Maximum Extension Distances](#) section.



RJ45 connector for LAN port **RJ45 connector for TPS input port**

Wiring of TPS and LAN Cables

Lightware recommends the termination of LAN cables on the basis of TIA/EIA T 568 A or TIA/EIA T 568 B standards.

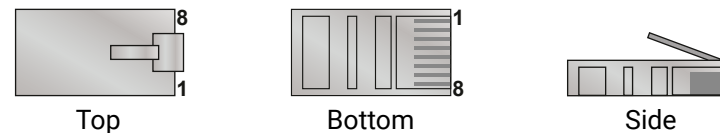

Pin	TIA/EIA T568 A	Color and name	TIA/EIA T568 B	Color and name
1		white/green stripe		white/orange stripe
2		green solid		orange solid
3		white/orange stripe		white/green stripe
4		blue solid		blue solid
5		white/blue stripe		white/blue stripe
6		orange solid		green solid
7		white/brown stripe		white/brown stripe
8		brown solid		brown solid

You can find more information about TPS interface in the [TPS Interface](#) section.

3.3.5. USB Connector

The extender provides standard USB 2.0 mini B-type connector for software control purpose.

3.3.6. IR Connector

IR detector and IR emitter can be connected to the receiver with TRS (Tip, Ring, and Sleeve) connectors. They are also known as (3,5 mm or approx. 1/8") audio jack, phone jack, phone plug, and mini-jack plug. The pin assignments are the following for the detector and the emitter:

Detector – 3-pole TRS		Emitter – 2-pole TS	
1 Tip	Signal (active low)	1 Tip	+5V
2 Ring	GND	2 Ring	Signal (active low)
3 Sleeve	+5V	3 Sleeve	

INFO: Ring pole of the emitter is optional. If your IR emitter has three-pole TRS plug, then the Ring and the Sleeve are the same signal (Output -).

You can find more information about Infrared interface in the [IR Interface](#) section.

3.3.7. RS-232 Connector

The receiver contains a 3-pole Phoenix connector which is used for RS-232 serial connection.

Pin nr.	Signal
1	Ground
2	TX data
3	RX data

Compatible Plug Type

Phoenix® Combicon series (3.5mm pitch, 3-pole), type: MC 1.5/3-ST-3.5.

You can find more information about RS-232 interface in the [Serial Interface](#) section.

3.3.8. Relay Connector

The receiver contains a 4-pole Phoenix connector which is used for relay connection.

Pin nr.	Signal
1	Pin 1 for Relay 1
2	Pin 2 for Relay 1
3	Pin 1 for Relay 2
4	Pin 2 for Relay 2

Relay connector pin assignment

INFO: The maximum ratings for each relay are 30V and 1A, AC/DC.

Compatible Plug Type

Phoenix® Combicon series (3.5mm pitch, 4-pole), type: MC 1.5/4-ST-3.5.

You can find more information about relay interface in the [Relay Interface](#) section.

3.4. TPS Receiver Concept

HDMI-TPS-RX110AY is a multifunctional receiver with HDBase™ (TPS) technology. The device can be controlled via many kind of interfaces, e.g. Ethernet, USB, RS-232, and Infrared. The receiver is built with audio de-embedder and relay function.



- + Ethernet
- + RS-232
- + Infrared
- + Local USB
- + Relay

Summary of the interfaces

3.5. Port Diagram

The following figure describes the port diagram of the device:

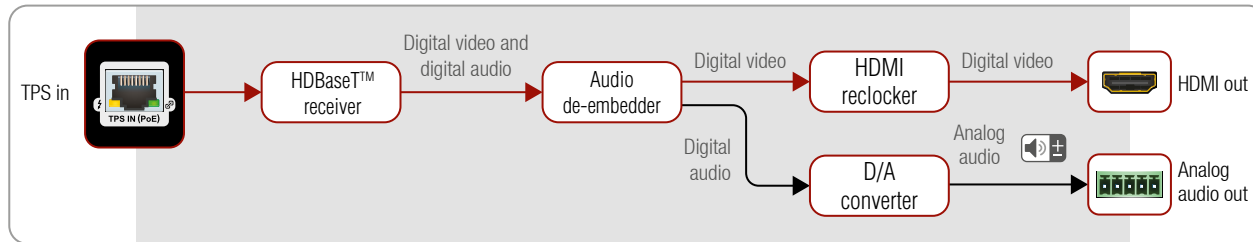

Port diagram of HDMI-TPS-RX110AY receiver

The device receives HDMI/DVI, Ethernet, RS-232, Infrared signals on the TPS input line. A/V signals are processed in the HDBaseT™ receiver unit. The audio de-embedder separates the digital audio and video signals. The digital video signal through the HDMI re-clocker can be forwarded to the local sink device by the HDMI output port while digital audio signal is converted to analog by the digital-analog (D/A) converter and forwarded to the local audio sink device by the analog audio output port.

3.6. TPS Interface

The device is built with TPS (Twisted Pair Single) interface which are using HDBaseT™ technology. It means the unit receives video, audio, Ethernet, RS-232 and Infrared signals via a single CATx cable.

TPS Interface Working Modes

The TPS working mode between the transmitter and the receiver is determined by the mode set in them. Both devices TPS mode settings together determine the finally established TPS transmission mode.

The following TPS modes are defined in the receiver:

- **Auto:** The TPS mode is determined automatically.
- **HDBaseT:** Ideal for high resolution signals up to 4K.
- **Long reach:** Ideal for big distances up to 1080p@60Hz with extended cable lengths.
- **LPPF1*:** Only RS-232 communication is transmitted (@ 9600 baud).
- **LPPF2*:** Only RS-232 (@ 9600 baud) and Ethernet communication are transmitted.

* LPPF: Low Power Partial Functionality.

		Selected mode on RX side				
		LPPF1	LPPF2	HDBaseT	Long reach	Auto
Selected mode on TX side	LPPF1	LPPF1	LPPF1	LPPF1	LPPF1	LPPF1
	LPPF2	LPPF1	LPPF2	LPPF2	LPPF2	LPPF2
	HDBaseT	LPPF1	LPPF2	HDBaseT	Long reach	HDBaseT
	Long reach	LPPF1	LPPF2	Long reach	Long reach	Long reach
	Auto	LPPF1	LPPF2	HDBaseT	Long reach	HDBaseT **

** If there is valid HDMI/DVI signal is on the TX side, the TPS mode will be HDBaseT on both side. If the transmitter does not transmits HDMI/DVI signal, the TPS mode will be changed to LPPF2 or LPPF1 automatically. Long reach mode is not available when both sides are set to Auto mode.

When using automatic operation mode selection, the device determines the mode of operation. If both halves are set to Auto mode, the source side is the initiator. It will negotiate each state transition with its sink side partner.

When one of the devices is configured to manual operation mode selection, the other device may be placed in automatic mode. In this case, the mode transition negotiation is initiated by the host-managed device and the auto-mode device follows through. The allowed cable lengths and resolutions are listed in the [Maximum Extension Distances](#) section.

3.7. Audio Interface

3.7.1. Audio Input

The device can receive embedded audio signal on the TPS input line.

3.7.2. Audio Output Modes

The device can transmit two types of audio:

- Embedded (HDMI) and
- Analog balanced stereo audio.

Audio de-embedding

The receiver has built-in audio de-embedder what means the device is able to receive HDMI signal with embedded audio via TPS line and can separate to video and audio signals on the output side.

ATTENTION! De-embedding function supports 2 channel PCM audio signals only. Other audio formats are not supported and de-embedding will not be successful.

3.7.3. Audio Options - Example

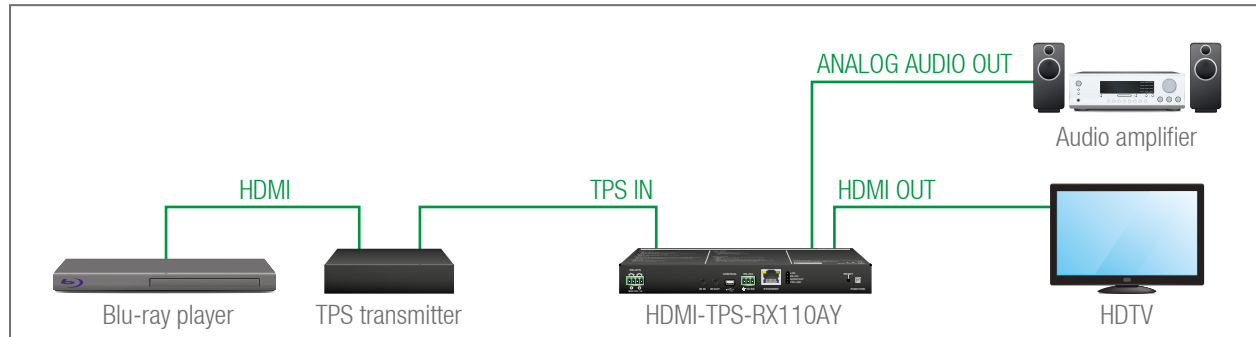

The Concept

The source is a Blu-ray player which sends audio and video signals on HDMI to the transmitter. The receiver accepts the signal on the TPS line, the audio signal is still embedded. HDMI-TPS-RX110AY makes de-embedding the AV signal to separated digital audio and analog audio signals and transmit them to the HD TV and the audio amplifier.

The following ways are available for the audio devices:

- The **Receiver** transmits the digital audio signal together with the video signal to the **HDTV**.
- The **Receiver** de-embeds the digital audio signal and converts it to analog one. It is transmitted to the **Audio amplifier**. So the **HDTV** provides the picture and **Audio amplifier** provides the sound. In this case digital audio on HDMI line needs to be muted.

3.8. Video Interface

The device can receive digital video signal via TPS line from any HDBaseT™ compliant transmitter, matrix or matrix board. On the output side the receiver transmits HDMI signal toward the sink.

Video Interface - Example

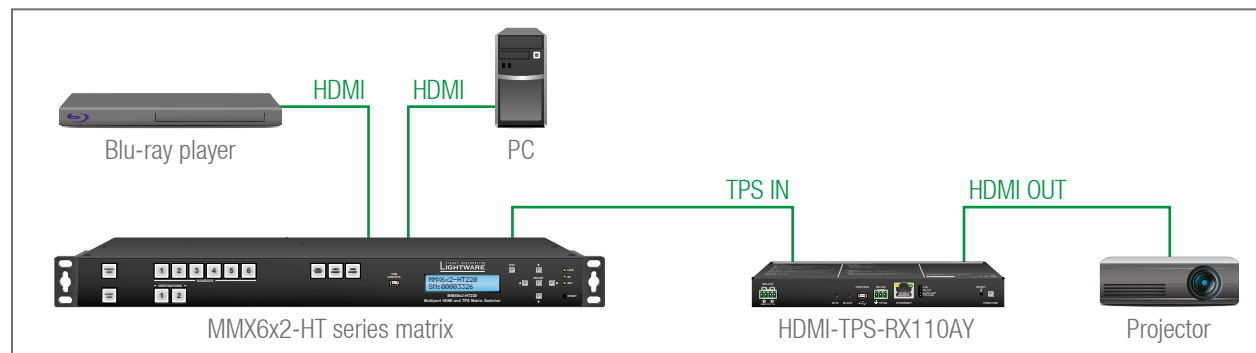

The Concept

The Receiver is connected to the Matrix which has two sources: a Blu-ray player and a PC. The input source can be selected in the matrix which transmits the video signal toward the receiver via the TPS interface.

3.9. Control Features

HDMI-TPS-RX110AY has several control functions. This chapter is about to present the possibilities through two simple layout examples.

System Control via Local Ethernet (Example)

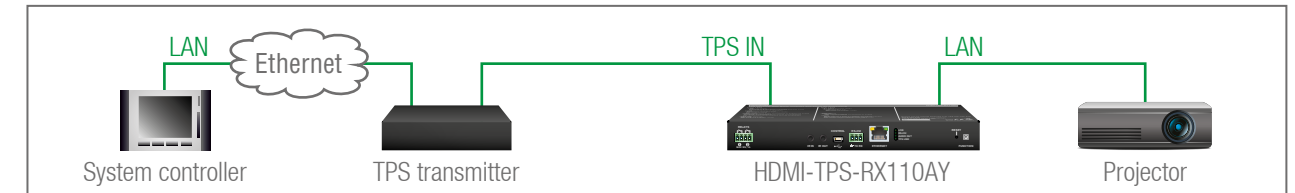

The following ways are available for device control:

- The **System controller** can communicate with the **Receiver** via the TPS line of the **Transmitter** with using LW2/LW3 protocol commands.
- The **System controller** can communicate directly with the **Projector** via their IP:port address.
- The **Receiver** can send a commands (e.g. as an action by the Event Manager) to the IP:port address of the **Projector** by using LW3 protocol methods.

System Control via Local RS-232 (Example)

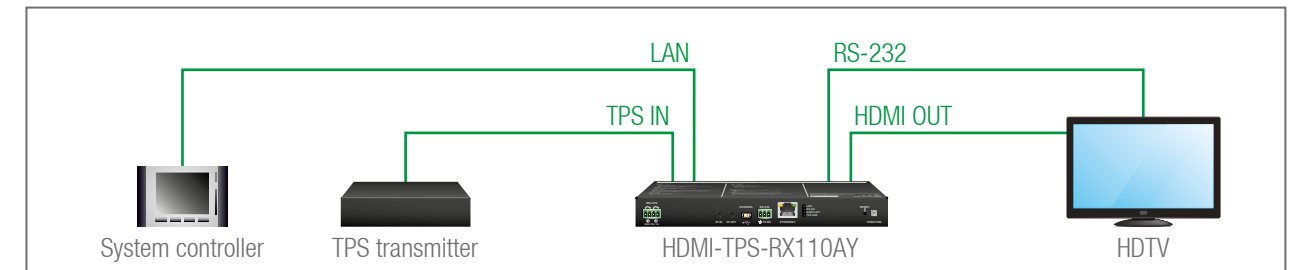

The following ways are available for controlling the devices:

- The **System controller** can communicate with LW2/LW3 protocol commands via the local RS-232 port of the **Receiver**.
- The **System controller** can send TCP or UDP messages to the IP:port address of the **Receiver** by using LW3 protocol methods.
- The **Receiver** can send LW3 protocol commands to the **HDTV** via the local RS-232 port.

3.9.1. Serial Interface

Technical Background

Serial data communication can be established via the local RS-232 port (Phoenix connector) or via the TPS lines. The RS-232 ports – which are connected to the CPU – can be configured separately (e.g. if the Baud rates are different, the CPU does the conversion automatically between the ports). The RS-232 port can be switched to Pass-through mode, Control mode, or Command Injection mode; see the figure below.

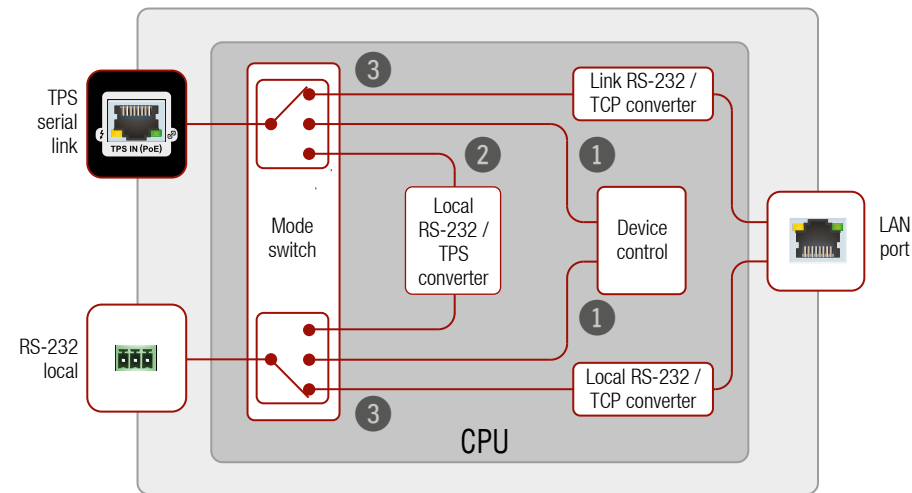

Block diagram of the serial interface

The following settings are defined:

- ① The Local and the TPS serial port is in **Control mode**.
- ② The Local and the TPS serial port is in **Pass-through mode**.
- ③ The Local and the TPS serial port is in **Command Injection mode**.

INFO: All settings are available in the LDC software, see settings in the [RS-232](#) section.

Only one mode can be used at the same time: Control mode, or Pass-through mode, or Command Injection mode. If you choose one of them, TPS serial link and local RS-232 port will operate in the same mode.

Pass-through Mode

In pass-through mode, the given device forwards the data that is coming from one of its ports to another same type of port. The command is not processed by the CPU. Incoming serial data is forwarded from TPS input port to local RS-232 port and vice versa inside the receiver.

Control Mode

The incoming data from the given port is processed and interpreted by the CPU. The mode allows to control the receiver directly. LW2 or LW3 protocol commands are accepted – depending on the current port setting.

Command Injection Mode

In this mode, the receiver works as an RS-232 bidirectional converter. The TPS signal is converted to RS-232 data and vice versa. TCP/IP port numbers are defined for the serial ports (TPS and local) for this purpose. E.g. the default Command Injection port number of the local RS-232 port is 8001. If a command is coming from the TPS interface which addresses to the port no. 8001, it will be transmitted to the Tx pin of the local RS-232 port. That works in the opposite direction of course and the method is the same on the serial interface of the TPS port as well.

RS-232 Signal Transmission – Example

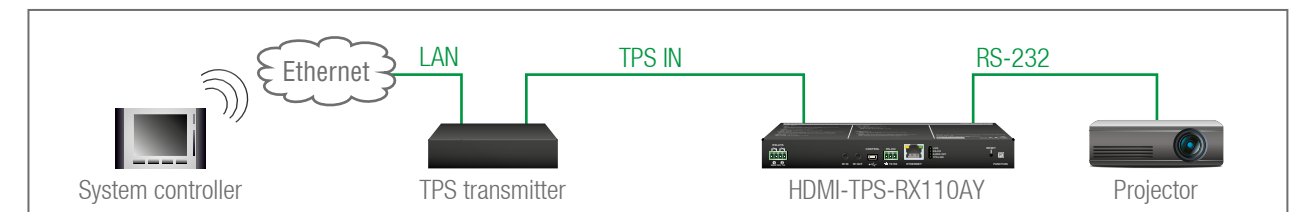

The Concept

The System controller can send commands to the receiver through the TPS transmitter and is able to remote control the projector via RS-232.

Settings

- **System controller:** wireless IP connection to the same Ethernet as the transmitter is connected to. Use a dedicated software tool (e.g. a terminal) which is suitable for sending commands via TCP/IP to a certain IP:port address.
- **Transmitter:** set the RS-232 mode to Command Injection on TPS output port. Set the further parameters (Baud rate, Data bits, etc.) in accordance with the specifications of the projector. The transmitter will transmit the RS-232 data toward the receiver.
- **Receiver:** set the RS-232 mode to Pass-through on RS-232 port.
- **Projector:** note the RS-232 port setting that is specified by the Manufacturer. Connect a suitable serial cable with the proper wiring.

3.9.2. RS-232 Recognizer

DIFFERENCE: This feature is available only in HDMI-TPS-RX110AY-Plus model.

This tool is able to recognize and store the incoming RS-232 message until the previously defined string (delimiter) is arrived or the timeout elapsed after the last data. The last incoming serial data is stored and it can trigger an action in Event Manager.

RS-232 Recognizer Example

When the **HDMI-TPS-RX110AY-Plus** has an active video signal, the transmitter login the VC codec automatically. In this case the RS-232 operation mode of the TPS receiver needs to be set to **Control**.

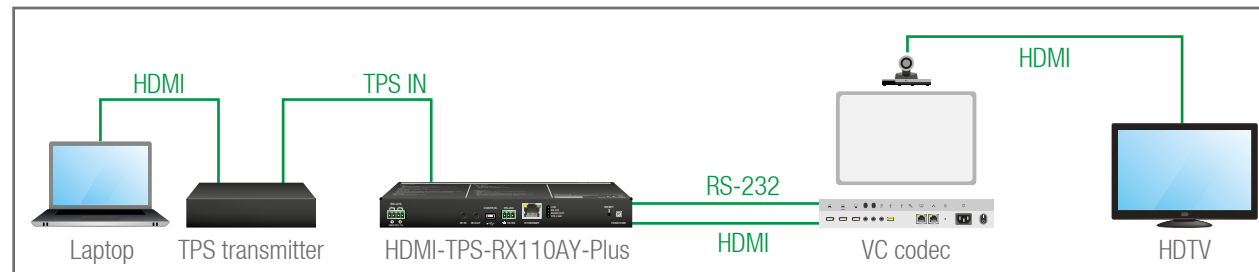

When the active signal appears on the TPS input port of the HDMI-TPS-RX110AY-Plus, it triggers a bi-directional communication with the VC codec via RS-232:

- ▶ HDMI-TPS-RX110AY-Plus (starts the communication on RS-232): **PING**
- ◀ VC codec (requests the login name): **Login name:**
- ▶ HDMI-TPS-RX110AY-Plus (sends the login name): **Admin**
- ◀ VC codec (requests the password): **Password:**
- ▶ HDMI-TPS-RX110AY-Plus (sends the password): **Admin**

Configure the recognizer for the serial communication firstly, after that, set the events in the Event Manager.

The RS-232 recognizer settings has to be done with Lightware Device Controller Software (see details in see [Message Recognizer](#) section) or with LW3 protocol commands (see more information in [RS-232 Recognizer](#) section).

Create the following events in the Event Manager:

E1. When the signal is present on I1 port of the HDMI-TPS-RX110AY-Plus, it sends a message '**PING**' on P1 port of RS-232 to the VC codec. For more details see [Sending a Message \(ASCII-format\) via Serial Port](#) section.

E2. Set a condition where **Login name:** is the recognized RS-232 message. Action is sending serial message ('**Admin**') on the P1 port to the VC codec.

E3. Set a condition where **Password:** is the recognized RS-232 message. Action is sending serial message ('**Admin**') on the P1 port to the VC codec.

For more information about setting the events, see [Event Manager](#) section.

3.9.3. IR Interface

ATTENTION! For the complete usage attach the supplied IR emitter unit to the IR OUT and the IR detector unit to the IR IN connectors.

Technical Background

The Infrared signal transmission is similar to the serial data communication. The receiver contains dedicated IR I/O connection and also can transmit/receive IR signal via the TPS interface. The signal is in pronto HEX format in both cases.

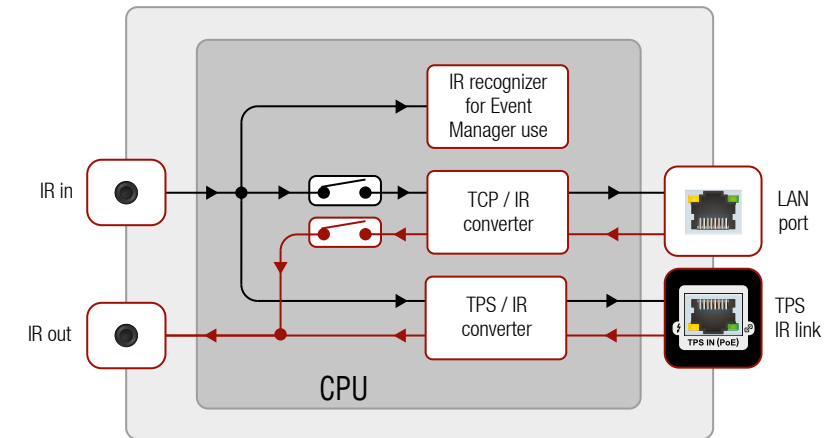

Block diagram of the IR interface

The most trivial usage of the IR interface is the transparent mode: signal received or sent on local IR ports are transmitted directly on the TPS IR link port and vice versa. Beside of this there is an IR recognizer in the device where you can assign actions in Event Manager for. The third option is the command injection mode (like at serial interface in the previous section) where you can send IR commands over LAN. Command injection mode can be turned on and off by input/output ports.

INFO: All settings are available in the LDC software, see settings in the [Infra](#) section.

INFO: The modulation of output IR signal can be turned off or on by LW3 command, see the [Enable/Disable Output Signal Modulation](#) section.

IR Signal Transmission - Example

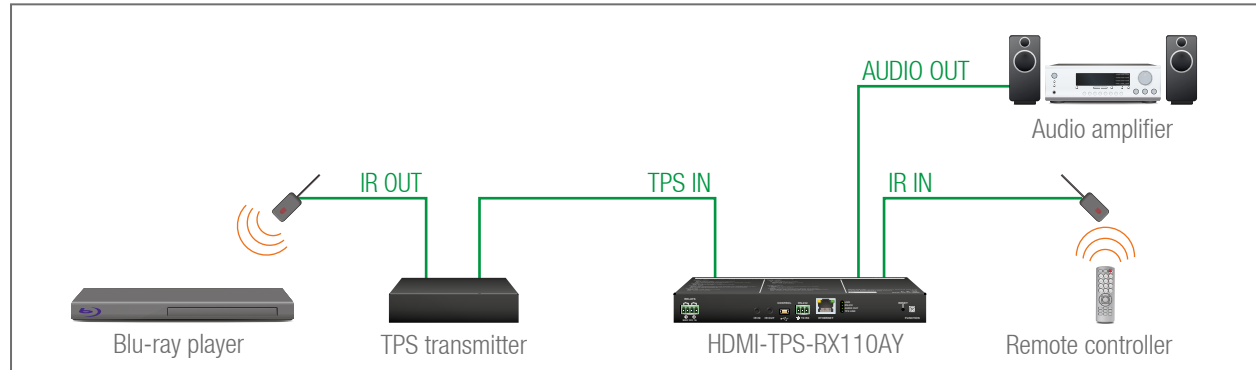

The Concept

An IR detector is attached to the Infrared input port of the Receiver and IR signals are sent by the Remote controller. The Receiver is connected to a compatible Transmitter built with IR output port via TPS line. An audio device is also connected to the audio output port of the receiver.

The following ways are available for controlling the devices:

- **Transparent mode:** IR signals are received over the local IR input port of the **Receiver** by the Remote controller. The signals transmitted further over the TPS line to the **Transmitter** which can control the **Blu-ray player** via an IR emitter.
- **Event Manager usage:** set an action in Event Manager that if the volume control buttons are pressed on the **Remote controller**, increase or decrease the volume of the analog audio port of the **Receiver**. In this case you can control the audio device via the Receiver remotely. See the details about the Event Manager settings in the [Event Manager](#) section.

Advanced IR Functionality

DIFFERENCE: This feature is available only in HDMI-TPS-RX110AY-Plus model.

HDMI-TPS-RX110AY-Plus can send Little-endian pronto hex IR codes on its IR output port.

It is possible in the following ways:

- With Lightware Device Controller software (for more details see [Sending pronto hex codes \(Little-endian format\)](#) section)
- With Event Manager (for more details see [Sending pronto hex codes \(Little-endian format\)](#) and [Event Manager](#) section)
- With LW3 protocol command (for more information see [Sending Pronto Hex Codes in Little-endian Format via IR Port](#))

Sending Bigger-endian pronto hex code is also available, see [Sending Pronto Hex Codes in Big-endian Format via IR Port](#).

3.9.4. Relay Interface

HDMI-TPS-RX110AY receiver contains two relay modules which can be accessed by a 4-pole Phoenix connector. The relays can be controlled by Lightware protocol commands (LW3) and Event manager actions can be assigned to the port.

ATTENTION! The device built with normally open (N.O.) contact relays which means when the unit is not powered (DC plug is disconnected), the relays will open.

INFO: The default state of each relay ports is open.

Application of Relays - Example

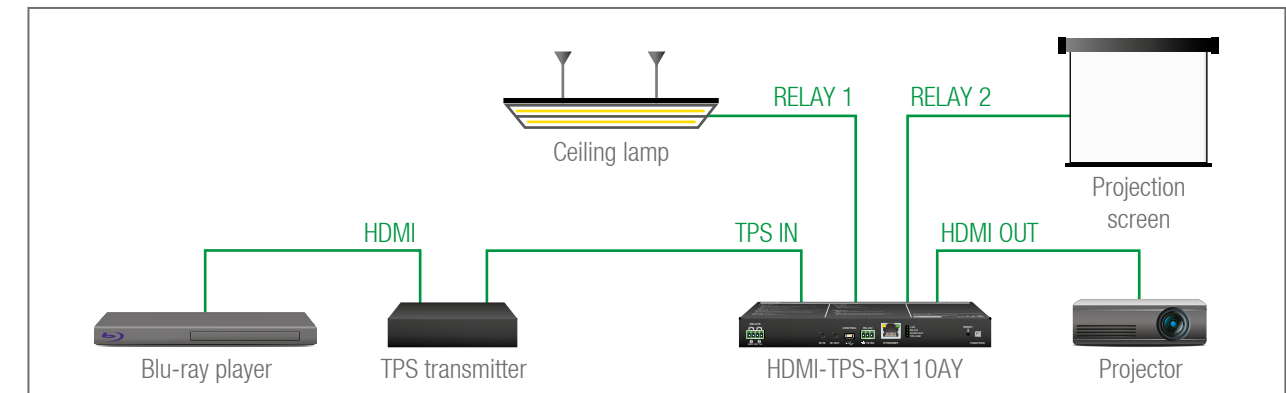

The Concept

Ceiling lamp is turned off by Relay 1 and projection screen is rolled down by Relay 2 when signal received from the transmitter over TPS input line.

Settings of the Receiver

- **Relay 1:** create an event in Event manager: when signal is present on Input 1 (I1) then set Relay 1 to be open. Also create another event when signal is not present on Input 1 (I1) then set Relay 1 to be closed.
- **Relay 2:** create an event in Event manager when signal is present on Input 1 (I1) then set Relay 2 to be closed. Also create another event when signal is not present on Input 1 (I1) then set Relay 2 to be open.

When Blu-ray player starts to play the presentation video, signal is received over TPS input line so Relay 1 opens which results turning off the lights, furthermore Relay 2 closes and the projection screen is rolled down. When the presentation is ended, signal ceases on the TPS input line, so Relay 1 closes which results turning on the lights, furthermore Relay 2 opens and projection screen returns to its enclosure.

See the details about the Event Manager settings in the [Event Manager](#) section.

3.9.5. Consuming Electronic Control (CEC) Interface

DIFFERENCE: This feature is available only in HDMI-TPS-RX110AY-Plus model.

Consumer Electronic Control (CEC) is a bi-directional communication, defined in the HDMI standard. This feature is for remote control of the source and sink devices in the A/V system.

HDMI-TPS-RX110AY-Plus model is able to send and receive CEC commands, from the input ports towards the source, and from output port towards the sink. For more information about sending CEC messages, see [Sending CEC Commands](#) section.

CEC has a dedicated pin in the HDMI connector. DVI connector does not contain this pin, so the CEC transmission brakes when HDMI-DVI connector or adapter is in the signal route.

CEC Application Example

When active signal is detected on TPS in, the transmitter sends a CEC message automatically to the HDTV to wake up.

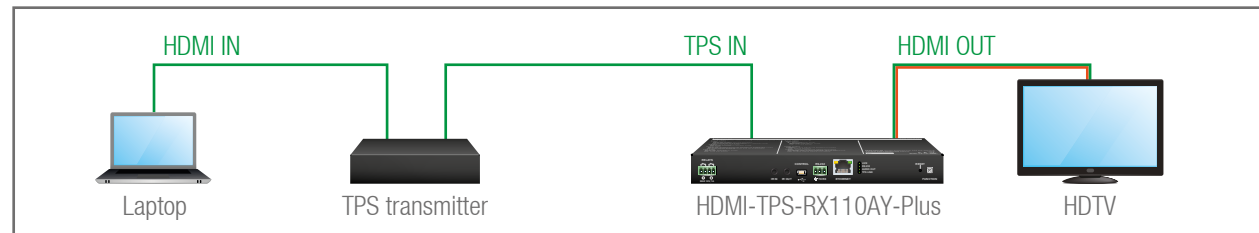

Create an event in the event manager:

- Set as a condition, that the signal is present on the output (O1),
- Set as an action then send a CEC command 'Image view on' O1 output port.

See the details about the Event Manager settings in the [Event Manager](#) section.

ATTENTION! The CEC command sending over TPS interface is working only with CEC-transparent TPS transmitters. For the details please download our Using CEC in Lightware Devices document on <https://lightware.com/support/guides-and-white-papers> website.

3.9.6. USB Control Interface

The device can be controlled over front panel USB mini B-type connector. This interface only supports LW3 protocol. The interface can be used to establish a connection to Lightware Device Controller software.

3.9.7. Ethernet Control Interface

The device can be controlled over front panel Ethernet standard RJ45 connector which connected to LAN. This interface supports both LW2 and LW3 protocols.

The interface can be used to remote control the device with Lightware Device Controller and establish the connection to Lightware Device Updater software and perform firmware upgrade.

3.10. Further Built-in Features

3.10.1. Automatically Launched Actions – The Event Manager

The Event Manager feature means that the device can sense changes on its ports and is able to react according to the pre-defined settings. Lightware Device Controller contains a user-friendly software tool and allows to create Events by defining a Condition and an Action.

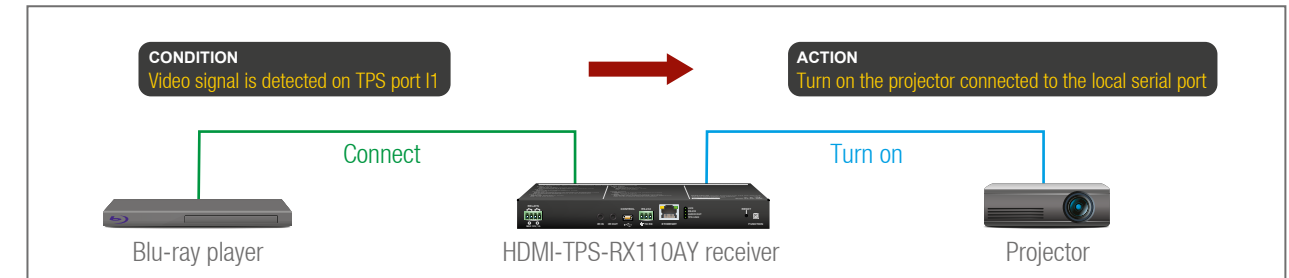

Event Manager example

See more information about the settings in the [Event Manager](#) section.

3.10.2. Receiver Cloning – Configuration Backup and Restore

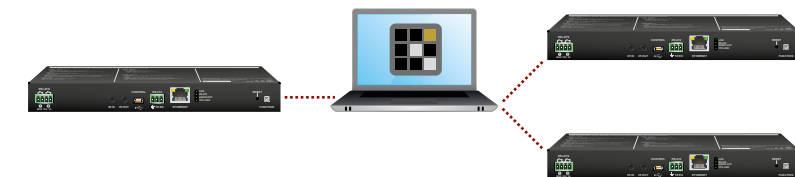

The receiver (configuration) cloning of HDMI-TPS-RX110AY is a simple method that eliminates the need to repeatedly configure certain devices to have identical (non-factory) settings. If the devices are installed in the same type of system multiple times then it is enough to set up only one device to fit the user's needs and then copy those settings to the others, thus saving time and resources.

See more information about the settings in the [Configuration Cloning \(Backup Tab\)](#) section.

3.10.3. Remote Firmware Upgrade of Connected Lightware Devices



The firmware of the Lightware TPS devices can be upgraded individually by Lightware Device Updater (LDU) software. HDMI-TPS-RX110AY contains a feature which allows having a faster and more comfortable firmware upgrade process. When the firmware of the connected extenders has to be upgraded the TPS connection is necessary towards the extenders – nothing else. The LDU will find the connected devices and can upgrade them.

The upgrade process is almost the same as in the case of the usual upgrade process. See the details of the process in the [Remote Firmware Upgrade of Connected Lightware Devices](#) section.

4

Operation

This chapter is about the powering and operating of the device describing the functions which are available by the front/rear controls:

- ▶ [FRONT PANEL - SPECIAL FUNCTIONS](#)
- ▶ [SOFTWARE CONTROL MODES](#)

4.1. Front Panel - Special Functions

4.1.1. Programmable Function Button



Action or an operation can be assigned to the **Function** button. “Function button pressed” is a condition that can be selected in the Event Manager. See more details in the [Event Manager](#) section.

#function_frontpanel

4.1.2. Enable Dynamic (DHCP) IP Address



The device gets a static IP address as a factory default setting. If this setting does not fit to the circumstances during install or usage, DHCP can be enabled from the front panel:

Step 1. Make sure the device is powered on and operational.

Step 2. Press and keep pressed the **Function** button for 5 seconds.

Step 3. After 5 seconds front panel LEDs start blinking; release the button and press it 3 times again quickly (within 3 seconds).

Step 4. The LEDs get dark, DHCP gets enabled.

#dhcp_frontpanel

4.1.3. Reset to Factory Default Settings



To restore factory default values, do the following steps:

Step 1. Make sure the device is powered on and operational.

Step 2. Press and keep pressed the **Function** button for 10 seconds. After 5 seconds front panel LEDs start blinking but keep on pressing the button.

Step 3. After 10 seconds the blinking gets faster; release the button and press it 3 times again quickly (within 3 seconds).

Step 4. The LEDs get dark, the device restores the factory default settings and reboots.

Factory default settings are listed in the [Factory Default Settings](#) section. *#factory_frontpanel*

4.1.4. Resetting the Device



In few cases (after firmware upgrade, etc) you may need to reset the device. Pushing the reset button results the same as you disconnect and reconnect the power adaptor to the receiver. To resetting the device follow the steps:

Step 1. Push the button with a thin object for a second.

Step 2. Wait until the device reboots. You can use the receiver when the LIVE LED is blinking slowly again.

ATTENTION! Resetting the device does not reset the settings to factory defaults. To reset factory default settings see previous section.

#reset_frontpanel #restart_frontpanel #reboot_frontpanel

4.1.5. Entering Bootload Mode



It may happen that the firmware upgrade process is not successful as the device cannot be switched to bootloader mode automatically. In this case, receiver device can be forced to switch to bootloader mode as follows:

Step 1. Make sure the transmitter is powered off.

Step 2. Press and keep pressed the **Function** button.

Step 3. Power on the receiver. If the device is switched to bootloader mode the LIVE LED is blinking quickly (less than 500 ms duty cycle). The other LEDs are off.

#bootload_frontpanel

4.2. Software Control Modes

User has more possibilities to control the device besides the front panel buttons. The following list contains the software control modes:

- **Lightware Device Controller (LDC):** you can connect to the device via our control software with using USB, RS-232 or Ethernet interfaces and control or configure the device as you wish. For the details see the [Software Control - Lightware Device Controller](#) chapter.
- **LW2 protocol commands:** you can configure the device by using the reduced command set of LW2 protocol. For more details see the [LW2 Programmers' Reference](#) chapter.
- **LW3 protocol commands:** you can configure the device by using the full-range command set of LW3 protocol. For more details see the [LW3 Programmers' Reference](#) chapter.

5

Software Control - Lightware Device Controller

The device can be controlled by a computer through RS-232, Ethernet, and USB interfaces by the Lightware Device Controller (LDC). The software can be installed on a Windows PC or macOS. The application and the User's Manual can be downloaded from www.lightware.com.

- ▶ [INSTALL AND UPGRADE](#)
- ▶ [RUNNING THE LDC](#)
- ▶ [ESTABLISHING THE CONNECTION](#)
- ▶ [PORT PARAMETERS MENU](#)
- ▶ [DIAGNOSTIC TOOLS](#)
- ▶ [EDID MENU](#)
- ▶ [CONTROL MENU](#)
- ▶ [EVENT MANAGER](#)
- ▶ [SETTINGS MENU](#)
- ▶ [CONFIGURATION CLONING \(BACKUP TAB\)](#)
- ▶ [ADVANCED VIEW WINDOW](#)

5.1. Install and Upgrade

INFO: After the installation, the Windows and the Mac application has the same look and functionality. This type of the installer is equal with the Normal install in case of Windows and results an updateable version with the same attributes.

Installation for Windows OS

Run the installer. If the User Account Control drops a pop-up message click **Yes**.

During the installation you will be prompted to select the type of the installation: **normal** and the **snapshot** install:

Normal install	Snapshot install
Available for Windows and macOS	Available for Windows
The installer can update only this instance	Cannot be updated
Only one updateable instance can exist for all users	More than one different version can be installed for all users

Comparison of installation types

ATTENTION! Using the Normal install as the default choice is highly recommended.

Installation for macOS

Mount the DMG file with double clicking on it and drag the LDC icon over the Applications icon to copy the program into the Applications folder. If you want to copy the LDC into another location just drag the icon over the desired folder.

Upgrading of LDC

Step 1. Run the application.

The **Device Discovery** window appears automatically and the program checks the available updates on Lightware's website and opens the update window if the LDC found updates.

The current and the update version number can be seen at the top of the window and they are shown in this window even with the snapshot install.

The **Update** window can also be opened by clicking the **About icon**  and the **Update** button.

Step 2. Set the desired update setting in the **Options** section.

- If you do not want to check for the updates automatically, uncheck **the circle**, which contains the green tick.
- If you want to postpone the update, a reminder can be set with different delays from the **drop down list**.
- If the proxy settings traverse the update process, set the proper values then click the **OK** button.

Step 3. Click the **Download update** button to start the upgrading.

The updates can be checked manually by clicking the **Check now** button.

5.2. Running the LDC

The common way to start the software is double-click on the LDC icon. But the LDC can be run by command line parameters as follows:

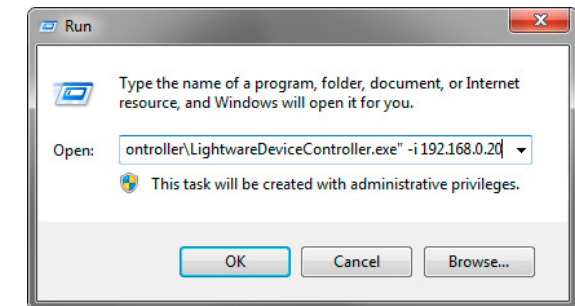

Connecting to a Device with Static IP Address

Format: LightwareDeviceController -i <IP_address>:<port>

Example: LightwareDeviceController -i 192.168.0.20:6107

The LDC is connected to a device with the indicated static IP address directly; the Device Discovery window is not displayed. When the port number is not set, the default port is used: 10001 (LW2 protocol - not supported by the UBEX extenders). For LW3 devices use the **6107** port number.

5.3. Establishing the Connection

Step 1. Connect the device to a computer via USB, RS-232 or Ethernet.

Step 2. Run the controller software; device discovery window appears automatically.

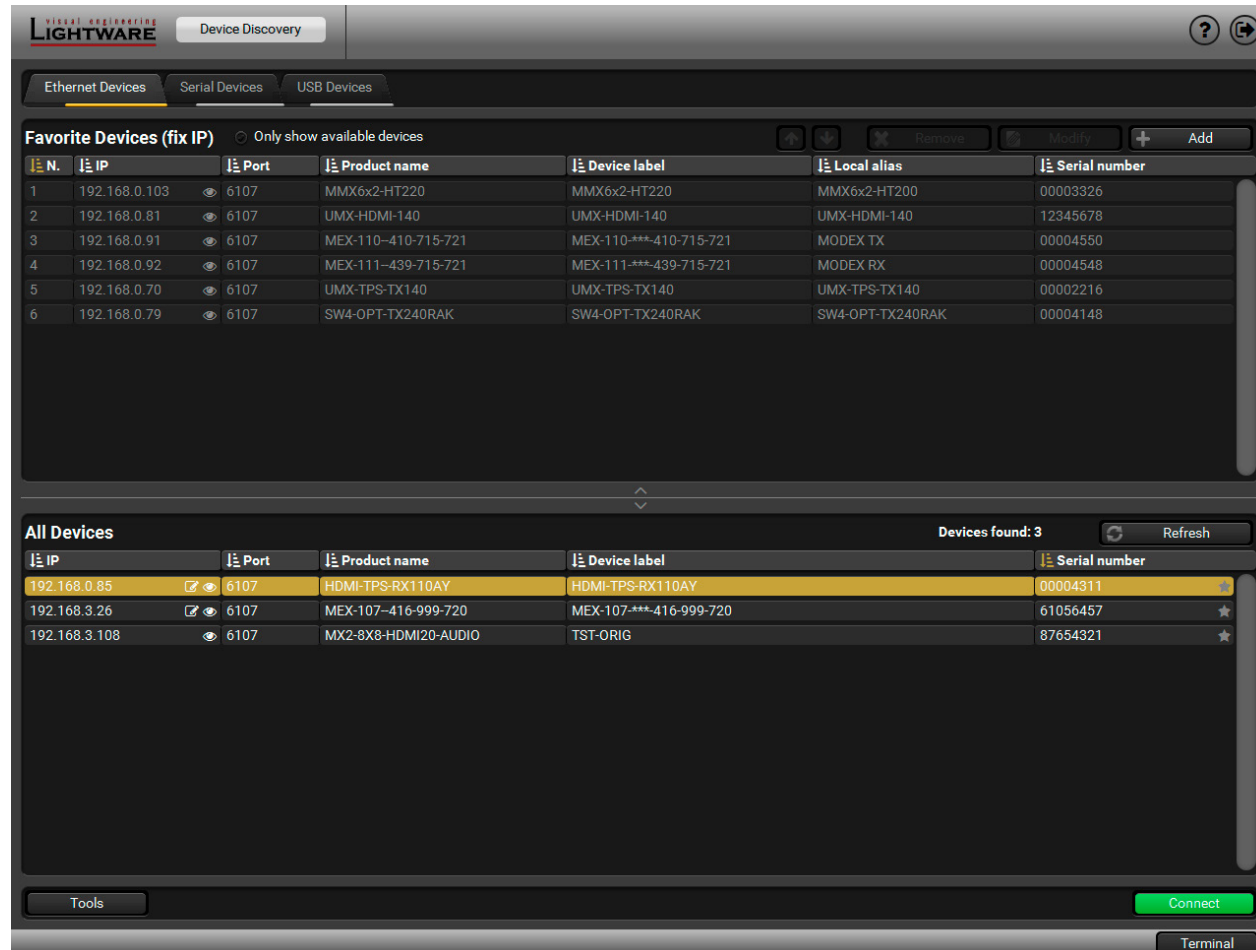

Device discovery window in LDC

Change IP Address

To modify IP address settings quickly it is not necessary to enter the device's settings/network menu, you can set them by clicking the pencil icon beside the IP address.

You can see the new settings only in this window.

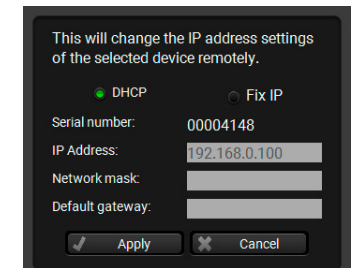

Identifying the Device

Clicking on the icon results the blinking of the status LEDs for 10 seconds. The feature helps to identify the device itself in the rack shelf. #*identifyme_idc*



Step 3. Select the unit from the discovered Ethernet devices or under Serial devices; when the device is connected through RS-232 click on the **Query** button next to the desired serial port to display the device's name and serial number. Double click on the transmitter or select the device and click on the **Connect** button.

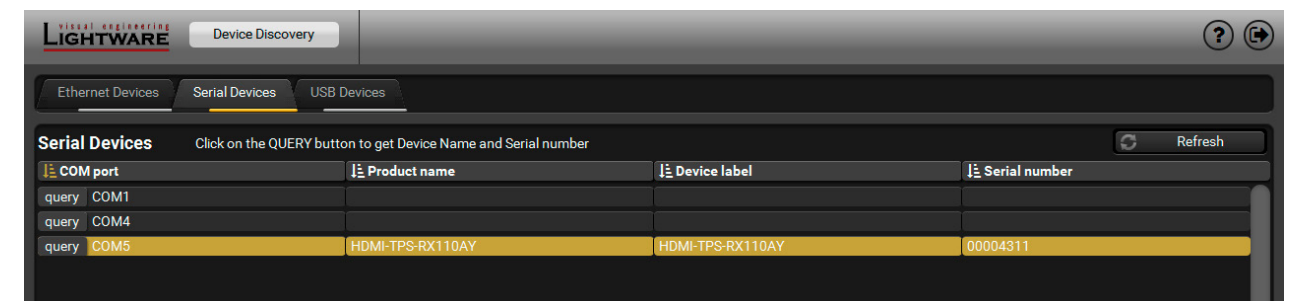

Serial devices tab in LDC

ATTENTION! Before the device is connected via the local RS-232 port, make sure that **Control mode** and **LW3 protocol** are set on the serial port.

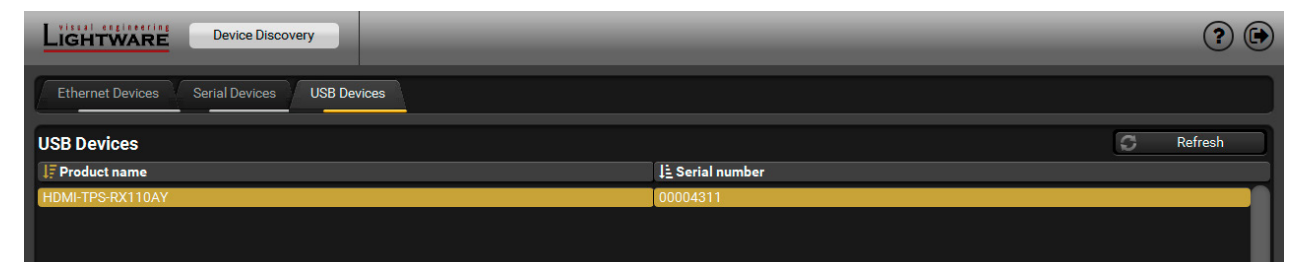

USB tab in LDC

5.4. Port Parameters Menu

5.4.1. Video Tab

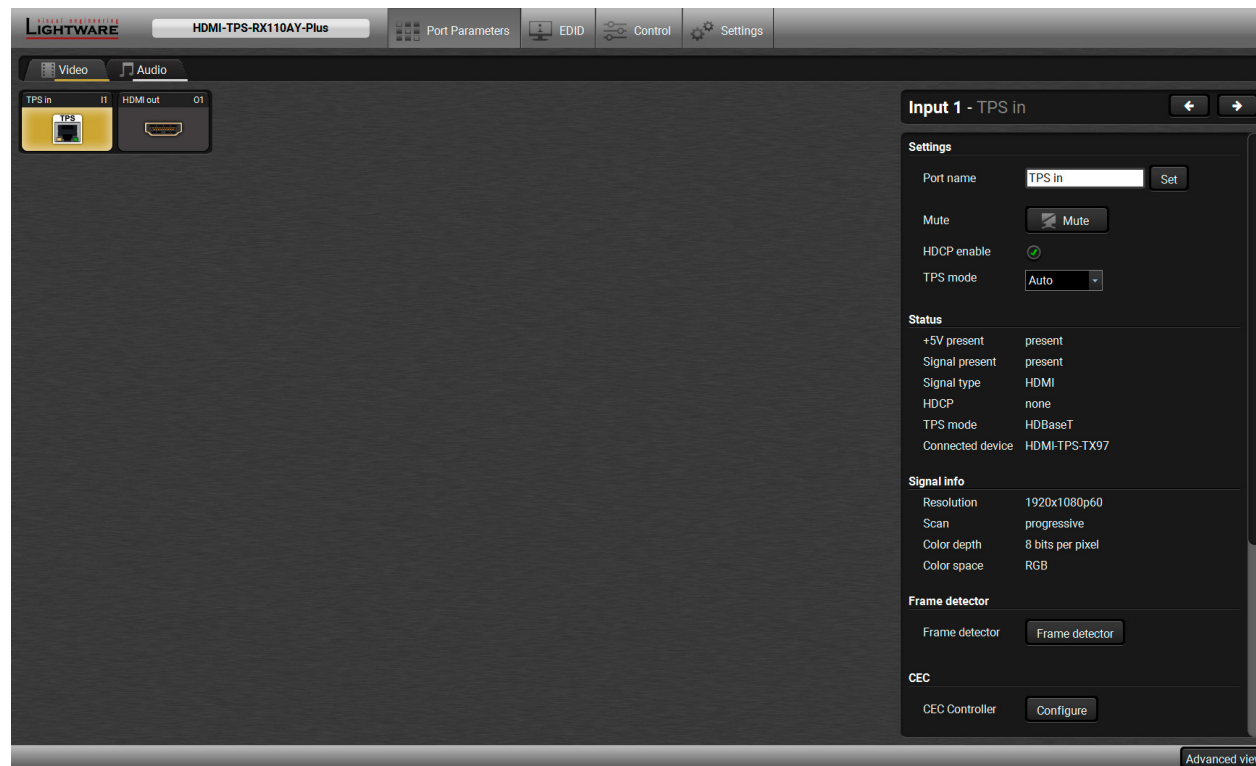

Video tab in Port parameters menu

The most important video related information and settings are available on this tab.

Link Video (I1)

This is the TPS (HDBaseT) input line of the receiver. Clicking on the TPS icon results the settings panel appearing on the right side. You can check the status of the line, signal info and current emulated EDID.

Available Settings:

- HDCP setting (enable / disable);
- TPS mode (see details in the [TPS Interface](#) section);
- [Cable Diagnostics](#) and [Frame Detector](#) tools;
- Reloading [Factory Default Settings](#).

HDMI OUT Video (O1)

This is the HDMI output line of the receiver. Clicking on the HDMI icon results the settings panel appearing on the right side. You can check the status of the line, and signal and display info.

Available Settings:

- Mute/Unmute port;
- Signal type: Auto, DVI, or HDMI;
- HDCP mode: Auto or Always;
- Power 5V mode: Auto, Always on, or Always off;
- Test pattern mode: Off, On, No signal;
- Test pattern clock source: 480p, 576p, or Original video signal;
- Test pattern: Red, Green, Blue, Black, White, Ramp, Chess, Bar, Cycle;
- [Frame Detector](#);
- Reloading [Factory Default Settings](#).

`#hdcp_ldc #tpsmode_ldc #cablediagnostics_ldc #mute_ldc #unmute_ldc #signaltype_ldc #power5v_ldc #testpattern_ldc #framedetector_ldc`

5.4.2. CEC Command Sending

DIFFERENCE: This feature is available only in HDMI-TPS-RX110AY-Plus model.

HDMI-TPS-RX110AY-Plus model is able to send and receive Consumer Electronic Control (CEC) commands. This feature is for remote control of the source or sink device. CEC is a bi-directional communication via HDMI cable.

ATTENTION! It can occur that the third-party device can receive, but not execute the command because it is not supported by the product. Check the accepted commands in the documentation of the device.

INFO: The first 2x2 bytes of the CEC commands contains identification data of the source and destination address. When the port is input, it is always 04 (from TV to Playback device 1.) when the port is output, it is always 40 (from Playback device 1. to TV).

The CEC panel is available on the port properties window of the **TPS input** and **HDMI output** ports.



CEC control panel on the HDMI out port properties window

- 1 **Drop-down command list** This list contains the basic CEC commands, most of them are displayed on the graphical interface, too (on the left side). Click on the **Send** button to execute sending the command.
- 2 **Custom command textbox** The text field is for sending hexadecimal commands to the source. The maximum length of the message could be 30 characters (15 bytes). Click on the **Send** button to execute sending the command.
- 3 **OSD string textbox** A max. 14 character-long text can be shown on the sink device. The send OSD (On-screen display) command textbox is the input field of the string. Alphanumeric characters, glyphs and space are accepted. Click on the **Send** button to execute the command.
- 4 **Received Command box** Displays all the sent (in red) CEC commands and the received answers (in blue) with a timestamp.
Legend of the received message:

```
< [10:33:17] ACK
```

 Answer for the acknowledged command.

```
< [10:35:01] NACK
```

 Answer for the not acknowledged command.

```
< [10:33:17] IN PROGRESS
```

 The command is in progress at the moment.

```
< [10:33:17] FAILED
```

 Answer for other failure.

```
< [10:35:40] feature_abort_<*>
```

 This is the most common answer from the third-party devices when the command is delivered, but the execution is refused. The cause of the refuse stands after 'feature_abort' expression.
- 5 **Clear button** Click on the **Clear** button to erase the content of the terminal window.
- 6 **CEC command button panel** This panel provides the quick and easy management of CEC commands. These buttons are pre-programmed with basic functions and sends commands towards the sink. The communication is displayed in the Received Command box. For the list of the commands see [Sending CEC Commands](#) section. Both the layout and functionality are similar to the design of a remote control.

ATTENTION! Make sure that the controlled unit is CEC-capable and this function is enabled.

```
#cec_idc #new
```

5.4.3. Audio Tab

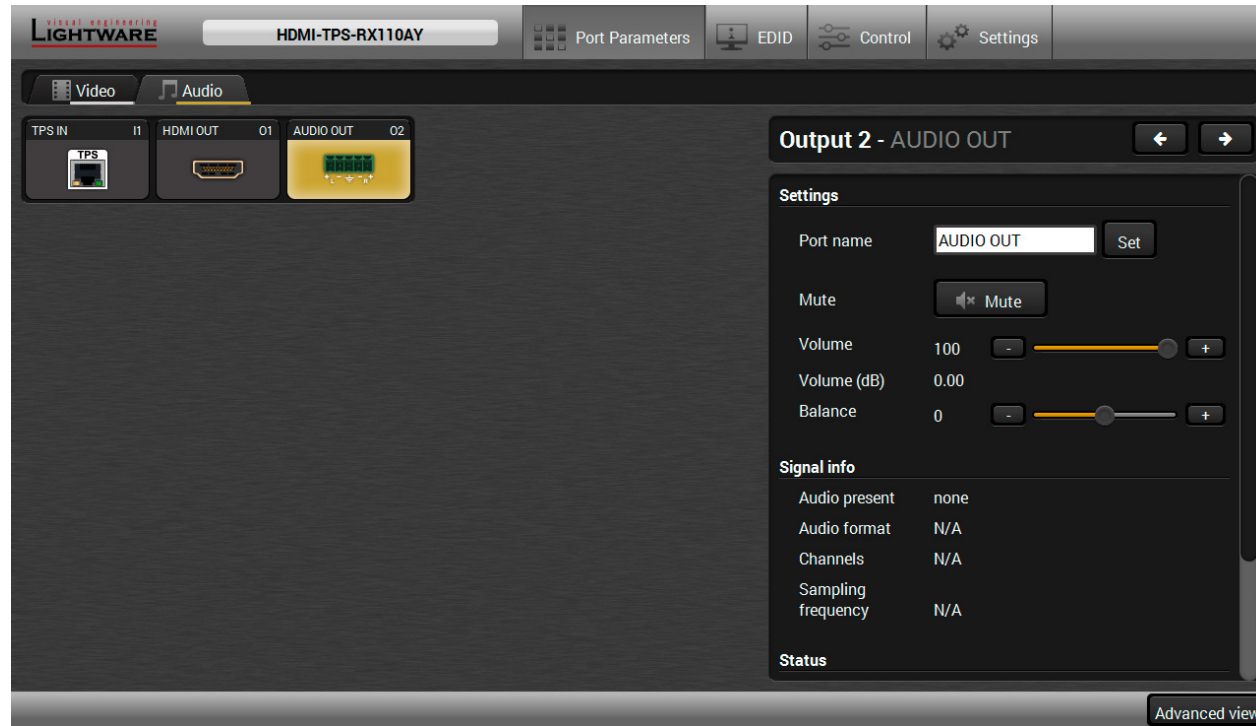

Audio tab in Port parameters menu

The most important audio related information and settings are available on this tab.

Link Audio (I1)

This is the embedded TPS audio input line of the receiver. Clicking on the TPS icon results the settings panel appearing on the right side. You can check the signal info of the port.

Available Settings:

- Mute/Unmute port;
- Lock/Unlock port;
- Reloading factory defaults (see factory default settings in the [Factory Default Settings](#) section).

HDMI OUT Audio (O1)

This is the embedded HDMI audio output line of the receiver. Clicking on the HDMI icon results the settings panel appearing on the right side. You can check the signal info of the port.

Available Settings:

- Mute/Unmute port;
- Lock/Unlock port;
- Reloading factory defaults (see factory default settings in the [Factory Default Settings](#) section).

Audio Out (O2)

This is the de-embedded analog audio output line of the receiver. Clicking on the HDMI icon results the settings panel appearing on the right side. You can check the signal info and the de-embedding status of the signal.

Available Settings:

- Mute/Unmute port;
- Volume (in percent);
- Balance;
- Reloading factory defaults (see factory default settings in the [Factory Default Settings](#) section).

`#mute_ldc #unmute_ldc #lock_ldc #unlock_ldc #volume_ldc #balance_ldc #analogaudio_ldc`

5.5. Diagnostic Tools

5.5.1. Frame Detector

The ports can show detailed information about the signal like blanking intervals and active video resolution. This feature is a good troubleshooter if compatibility problems occur during system installation. To access this function, open the port properties window and click on **Frame detector** button.

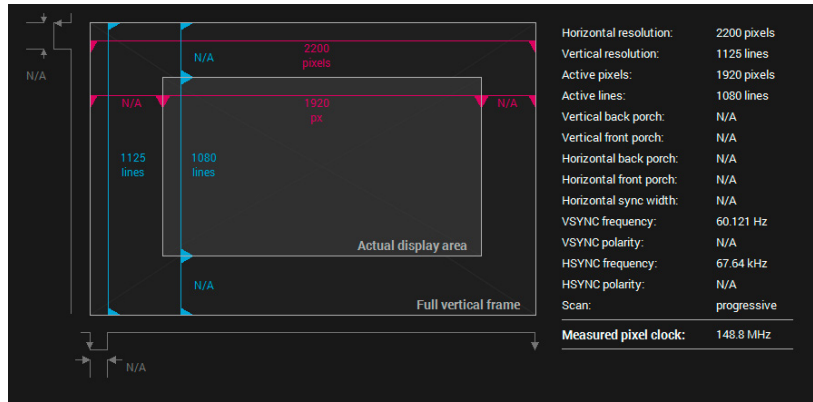

Frame detector window

Lightware's Frame Detector function works like a signal analyzer and makes possible to determine the exact video format that is present on the port, thus helps to identify many problems. E.g. actual timing parameters may differ from the expected and this may cause some displays to drop the picture.

Frame Detector measures detailed timings on the video signals just like a built-in oscilloscope, but it is much more easy to use. Actual display area shows the active video size (light gray). Dark gray area of the full frame is the blanking interval which can contain the info frames and embedded audio data for HDMI signals. Shown values are measured actually on the signal and not retrieved only from the HDMI info frames.

5.5.2. Cable Diagnostics

The cable diagnostics is a useful tool to determine any cable related issues in case of TPS connection. The estimated cable length and the quality of the link are measured periodically and the diagnostic window shows the values in real-time. If the green bars hit the first line in the middle they turn into red. It means the number of the errors – during the extension – is higher than recommended. The link might be alive but recovering of the received data is not guaranteed.

INFO: Each bar represents a differential line in the CATx cable. The inappropriate termination of the cable usually causes high error rates. Check the cable terminations or change the cable.

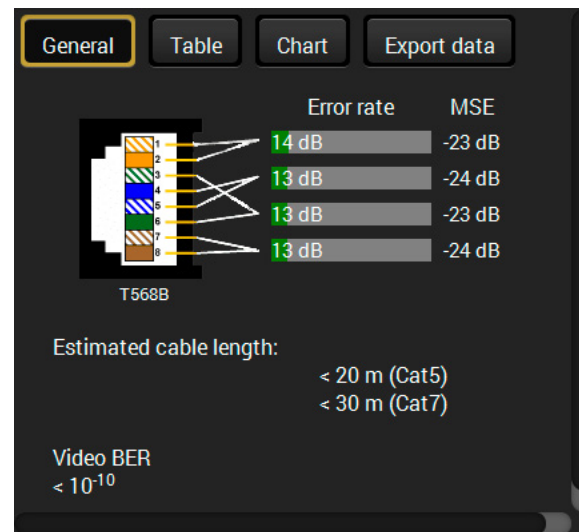

Reference Values

Value	Explanation
10 ⁻¹⁰ -10 ⁻⁹	Excellent image quality
10 ⁻⁸	Minor error, not recognizable by eyes
10 ⁻⁷	Sometimes recognizable flash on a special test pattern
10 ⁻⁶	Small noise can be seen
10 ⁻⁵	Easy to recognize image error
10 ⁻⁴	Bad image quality

Above displayed "Video BER < 10⁻¹⁰" value means that on average there is 1 bad pixel after 10¹⁰ pixels, which means the number of the bit errors is about 1 pixel in every 15 minutes.

INFO: You can find more details about maximum twisted pair cable distances in the [Maximum Extension Distances](#) section.

Table and Chart Views

Cable diagnostics can be displayed in advanced modes as well. Two ways are available: **table view** and **chart view**. Data can be exported to a file on clicking on the **Export data** button.

Date	MSE #1	MSE #2	MSE #3	MSE #4	Error rate #1	Error rate #2	Error rate #3	Error rate #4	Cable length
2016-11-12 09:57:23	-24	-22	-22	-22	28	52	32	34	< 20
2016-11-12 09:57:24	-24	-22	-22	-22	28	52	32	34	< 20
2016-11-12 09:57:25	-24	-22	-23	-23	28	46	30	34	< 20
2016-11-12 09:57:26	-24	-22	-22	-22	26	44	30	36	< 20
2016-11-12 09:57:27	-24	-22	-22	-22	26	44	30	36	< 20
2016-11-12 09:57:28	-24	-22	-23	-22	26	46	32	38	< 20
2016-11-12 09:57:29	-24	-22	-23	-22	26	46	32	38	< 20
2016-11-12 09:57:30	-24	-22	-23	-22	26	46	32	38	< 20

Table view of cable diagnostics

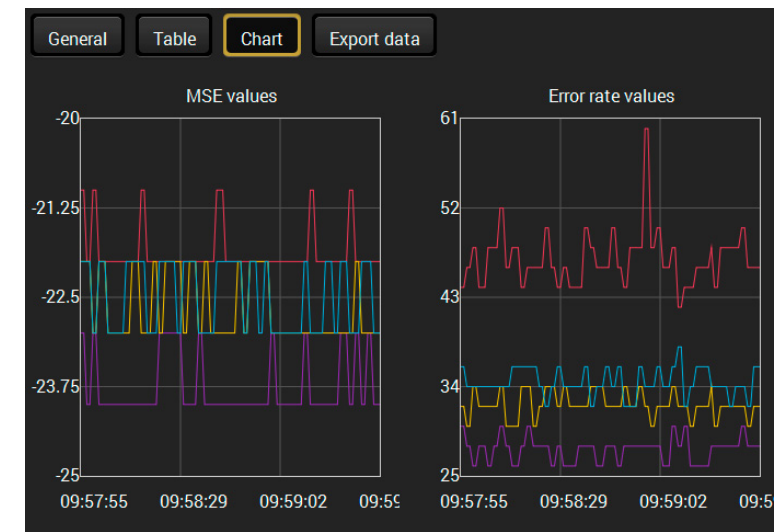
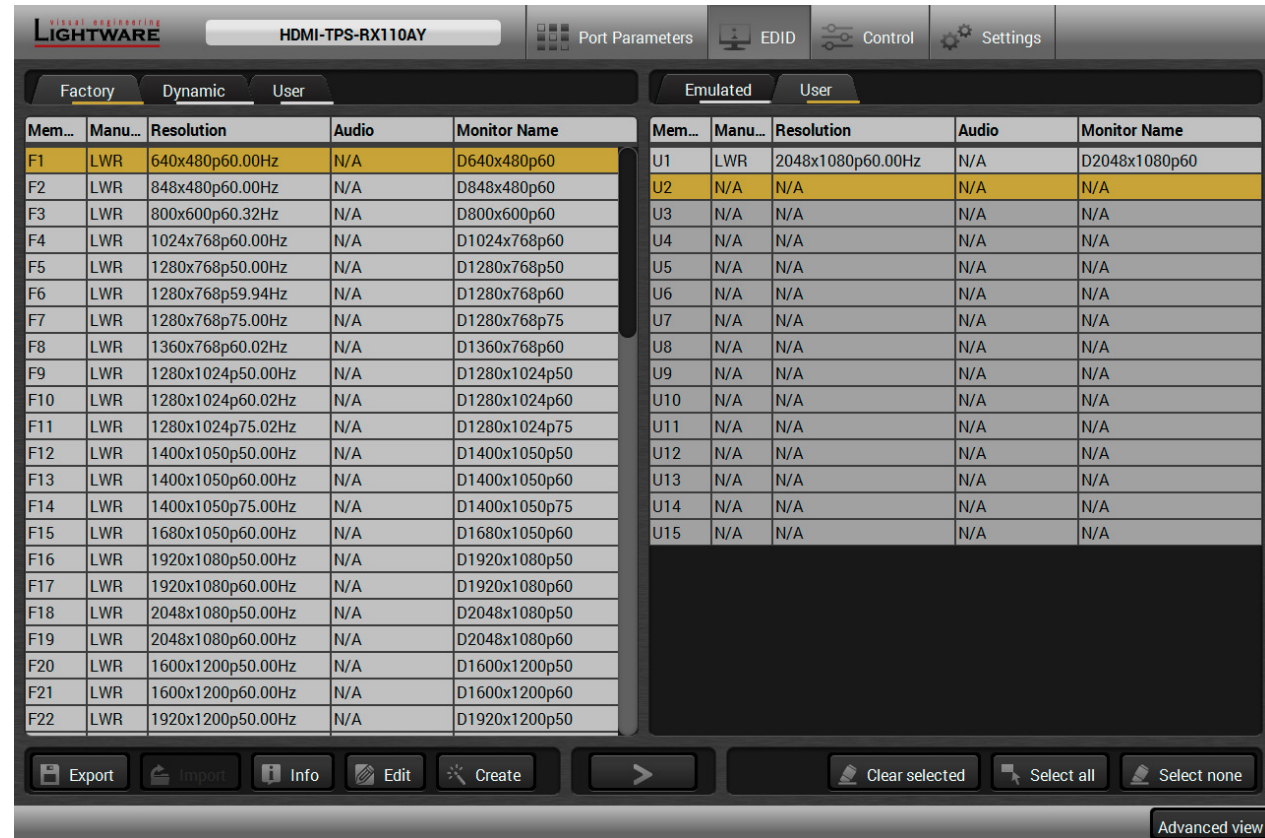

Chart view of cable diagnostics

#framedetector_idc #cablediagnostics_idc



5.6. EDID Menu

Advanced EDID Management can be accessed by selecting the EDID menu. There are two panels: left one contains Source EDIDs, right one contains Destination places where the EDIDs can be emulated or copied.



EDID menu

Control Buttons

-  Exporting an EDID (save to a file)
-  Importing an EDID (load from a file)
-  Display EDID Summary window
-  Opening Advanced EDID Editor with the selected EDID
-  Opening Easy EDID Creator
-  Executing EDID emulation or copying (Transfer button)
-  Deleting EDID (from User memory)
-  Selecting all memory places in the right panel
-  Selecting none of the memory places in the right panel

5.6.1. EDID Operations

Changing Emulated EDID

- Step 1.** Choose the desired **EDID list** on the source panel and select an **EDID**. 
- Step 2.** Press the **Emulated** button on the top of the Destination panel.
- Step 3.** Select the desired **port** on the right panel (one or more ports can be selected); the EDID(s) will be highlighted with a yellow cursor.
- Step 4.** Press the **Transfer** button to change the emulated EDID.

Learning an EDID

The process is the same as changing the emulated EDID; the only difference is the Destination panel: press the **User** button. Thus, one or more EDIDs can be copied into the user memory either from the factory memory or from a connected sink (Dynamic).

Exporting an EDID

ATTENTION! This function is working on Windows and macOS operating systems and under Firefox or Chrome web browsers only.

Source EDID can be downloaded as a file (*.bin, *.dat or *.edid) to the computer.

- Step 1.** Select the desired **EDID** from the Source panel (line will be highlighted with yellow).
- Step 2.** Press the **Export** button to open the dialog box and save the file to the computer. 

Importing an EDID

Previously saved EDID (*.bin, *.dat or *.edid file) can be uploaded to the user memory:

- Step 1.** Press the **User** button on the top of the Source panel and select a **memory** slot. 
- Step 2.** Press the **Import** button below the Source panel.
- Step 3.** Browse the file in the opening window then press the **Open** button. Browsed EDID is imported into the selected User memory.

ATTENTION! The imported EDID overwrites the selected memory place even if it is not empty.

Deleting EDID(s)

The EDID(s) from User memory can be deleted as follows:

- Step 1.** Press **User** button on the top of the Destination panel. 
- Step 2.** Select the desired **memory** slot(s); one or more can be selected (**Select All** and **Select None** buttons can be used). The EDID(s) will be highlighted with yellow.
- Step 3.** Press the **Delete selected** button to delete the EDID(s).

#edid_ldc

5.6.2. EDID Summary Window

Select an EDID from Source panel and press **Info** button to display EDID summary.



General

- EDID version: 1
- EDID revision: 3
- Manufacturer ID: SAM (Samsung Electric Company)
- Product ID: 8E09
- Monitor serial number: Not present
- Year of manufacture: 2012
- Week of manufacture: 9
- Signal interface: Digital
- Separate Sync H&V: -
- Composite sync on H: -
- Sync on green: -
- Serration on VS: -
- Color depth: Undefined
- Interface standard: Not defined
- Color spaces: RGB 4:4:4 & YCrCb 4:4:4
- Aspect ratio: 0.56
- Display size: 52 cm X 29 cm

EDID summary window

5.6.3. Editing an EDID

Select an EDID from Source panel and press Edit button to display Advanced EDID Editor window. The editor can read and write all descriptors, which are defined in the standards, including the additional CEA extensions. Any EDID from the device's memory or a saved EDID file can be loaded into the editor. The software resolves the raw EDID and displays it as readable information to the user. All descriptors can be edited, and saved in an EDID file, or uploaded to the User memory. For more details about EDID Editor please visit our website (www.lightware.com) and download EDID Editor user's manual.



Basic EDID

- Vendor / Product Information
- Display Parameters
- Power Management and Features
- Gamma / Color and Established Timings
- Standard Timings
- Preferred Timing Mode
- 2nd Descriptor Field
- 3rd Descriptor Field
- 4th Descriptor Field
- CEA Extension
- General
- Video Data
- Audio Data
- Speaker Allocation Data
- HDMI
- Colorimetry
- Detailed Timing Descriptor #1
- Detailed Timing Descriptor #2
- Detailed Timing Descriptor #3
- Detailed Timing Descriptor #4
- Detailed Timing Descriptor #5
- Detailed Timing Descriptor #6
- Save EDID

EDID Byte Editor

	0	1	2	3	4	5	6	7	8	9
0	00	FF	FF	FF	FF	FF	FF	00	4C	2D
10	8E	09	00	00	00	00	09	16	01	03
20	80	34	1D	78	0A	7D	D1	A4	56	50
30	A1	28	0F	50	54	BD	EF	80	71	4F
40	81	C0	81	00	81	80	95	00	A9	C0
50	B3	00	01	01	02	3A	80	18	71	38
60	2D	40	58	2C	45	00	09	25	21	00
70	00	1E	66	21	56	AA	51	00	1E	30
80	46	8F	33	00	09	25	21	00	00	1E
90	00	00	00	FD	00	18	4B	1A	51	17
100	00	0A	20	20	20	20	20	20	00	00
110	00	FC	00	54	32	34	42	33	30	31
120	0A	20	20	20	20	20	01	6C		

EDID Editor window

5.6.4. Creating an EDID - Easy EDID Creator

Since above mentioned Advanced EDID Editor needs more complex knowledge about EDID, Lightware introduced a wizard-like interface for fast and easy EDID creation. With Easy EDID Creator it is possible to create custom EDIDs in four simple steps. By clicking on the **Create** button below Source panel, **Easy EDID Creator** is opened in a new window. For more details about EDID Editor please visit our website (www.lightware.com) and download EDID Editor user's manual.

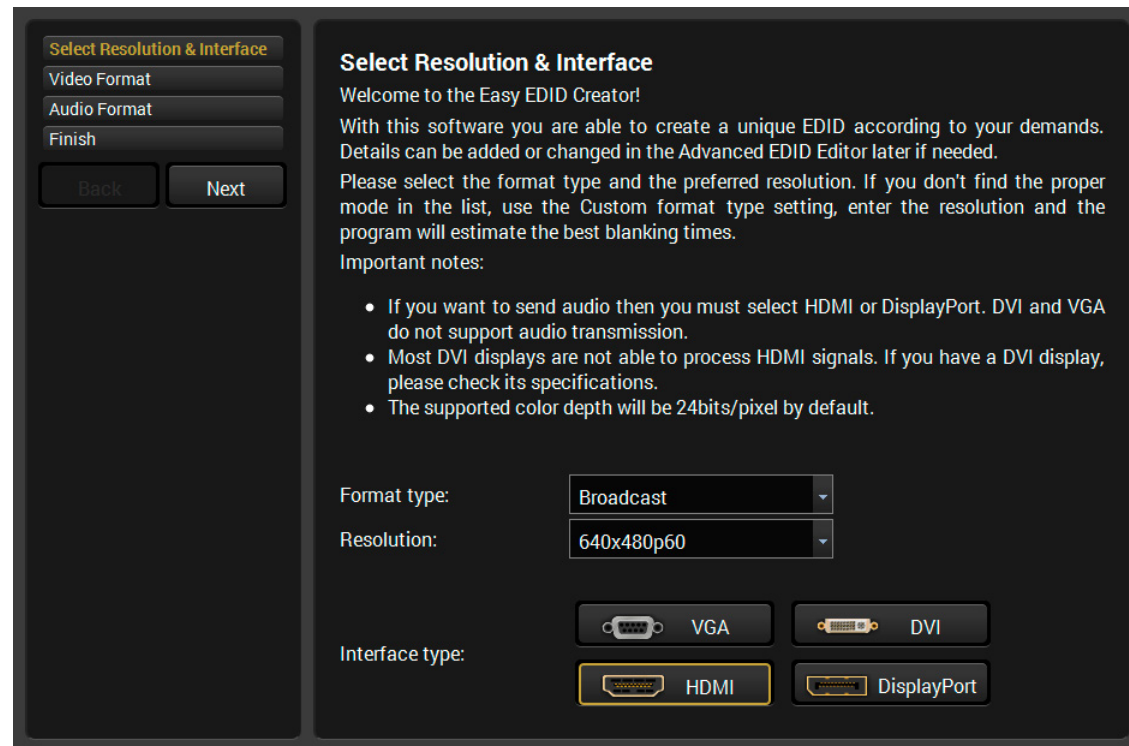

EDID Creator window

5.7. Control Menu

5.7.1. RS-232

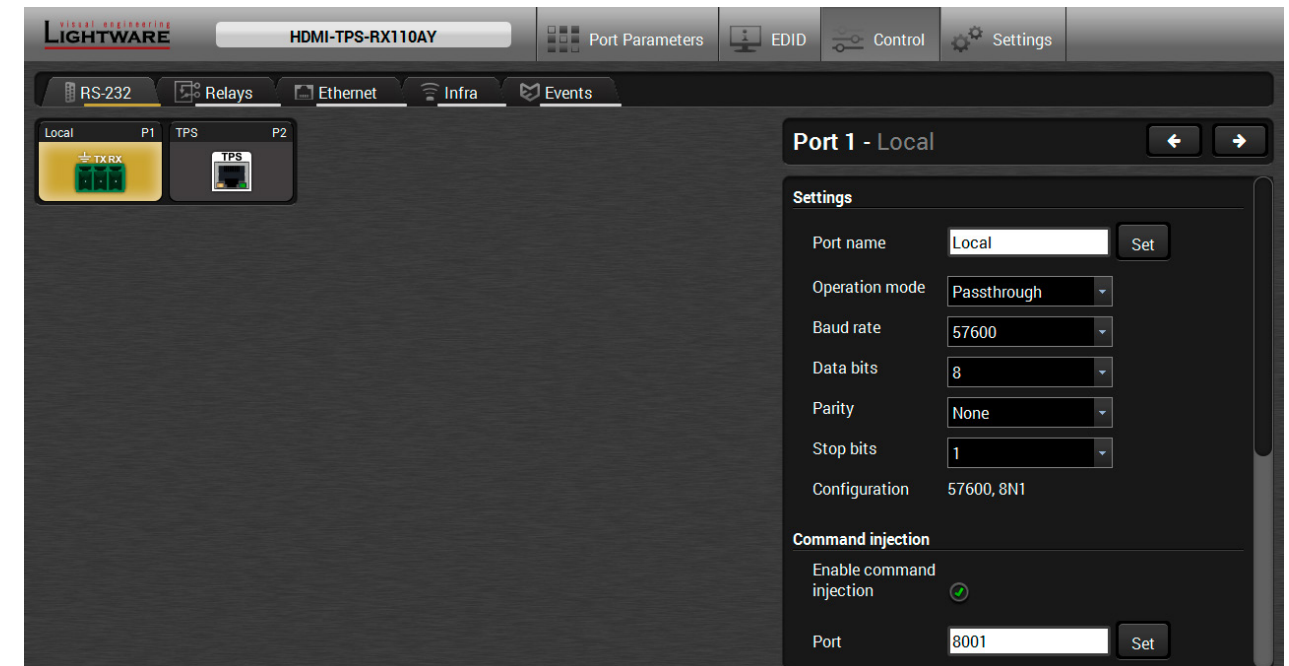

RS-232 tab in Control menu

The following settings and functions are available (both on local and TPS serial ports):

- Operation mode: Pass-through, Control, or Command Injection (for more details about serial interface modes see the [Serial Interface](#) section);
- Baud rate: 4800, 7200, 9600, 14400, 19200, 38400, 57600, 115200;
- Data bits: 8 or 9;
- Parity: None, Odd, or Even;
- Stop bits: 1, 1.5, or 2;
- Command injection: enable or disable;
- Command injection port number;
- Control protocol: LW2 or LW3;
- Message sending via serial port;
- Reloading factory defaults (see factory default settings in the [Factory Default Settings](#) section).

ATTENTION! Operation mode of the local and TPS serial ports can be set together only. It means if you set the local RS-232 port to Control mode, the TPS serial link will be changed to Control mode either automatically.

ATTENTION! If the receiver is connected to a TPS2 output board of a matrix frame, the RS-232 configuration settings (baud rate, data bits, e.t.c.) will not be changeable on the receiver side.

```
#rs232_idc #rs-232_idc #serial_idc #commandinjection_idc #message_idc
```

Message Recognizer

DIFFERENCE: This feature is available only in HDMI-TPS-RX110AY-Plus model.

HDMI-TPS-RX110AY-Plus model can analyze and store the received serial data. For more information see the [RS-232 Recognizer](#) section.

Put a tick to **Enable message recognizer on this port** to switch the recognizer on.

Delimiter sequence text box is for set the delimiter string in hex format. When this string is detected in the incoming serial data, the device saves the RS-232 message data from the first bit, until the delimiter (or the data between the two delimiters).

INFO: 0D0A is the factory default value, this is the hexadecimal code of Carriage Return and Line Feed. LW3 protocol commands ended with this formula, so the default value support the recognition of the LW3 commands and the stored changes automatically.

If the **Timeout** is enabled and set, the received data is saved when the timeout is elapsed after the last received message.

In **Received messages** box shows the last received and stored message in Text (RECOGNIZER.Rx), Hex (RECOGNIZER.RxHex), and Hash (RECOGNIZER.Hash) format. The Hex and Hash contains the delimiter.

Press the **Clear** button to erase this storage.

Clicking on **Reload** restores the [Factory Default Settings](#) of the recognizer.

ATTENTION! The Message recognizer settings are mirrored on the Local and TPS in serial ports.

INFO: Message recognizer operates independently of the RS-232 mode.

#recognizer_ldc #rs232recognizer_ldc #rs-232recognizer_ldc #new

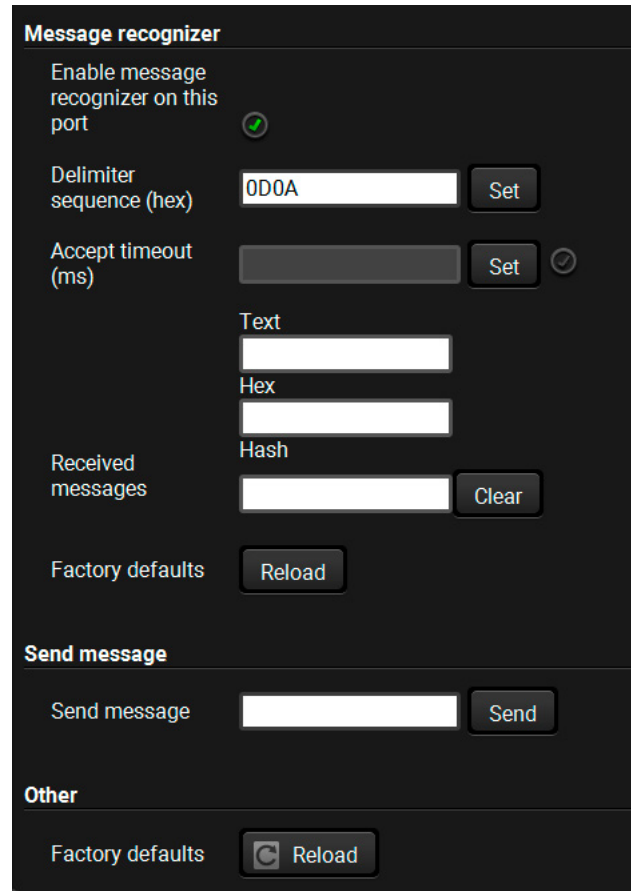

Configuration Example for the Message Recognizer

The detailed description below shows how to configure the message recognizer in [RS-232 Recognizer Example](#).

When the HDMI-TPS-RX110AY-Plus has an active video signal, the switcher login the VC codec automatically. The signal presence triggers a bi-directional communication with the VC codec via RS-232:

Step 1. Turn on the recognizer: Enable it on the P1 serial port.

Step 2. Set the delimiter (in hex format). In this case, the delimiter character is ':', which is '3a' in hex format. When the delimiter string is detected in the incoming serial data, the serial message is stored in string (in Rx and ActiveRx property), hex (in RxHex and ActiveHex property) and hash (in Hash and ActiveHash property) format. These stored content can be set as a condition in the event manager.

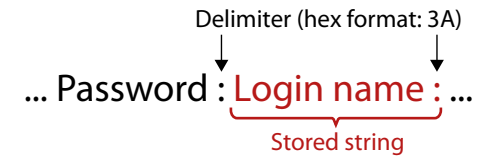

INFO: The stored content is the incoming data which arrives **before** the delimiter or **between** the two delimiters.

Step 3. Set the Active timeout 100. This property is responsible for erasing the temporary storage (ActiveRx, ActiveRxHex, ActiveHash) after the elapsing time. In the below example, it can be seen how does the recognizer properties change during the communication:

▶ HDMI-TPS-RX110AY-Plus: **PING**

Rx	RxHex	Hash	ActiveRx	ActiveRxHex	ActiveHash

◀ VC codec: **Login:**

Rx	RxHex	Hash	ActiveRx	ActiveRxHex	ActiveHash
Login:	4C6F67696E3A	2D8A5E38	Login:	4C6F67696E3A	2D8A5E38

▶ HDMI-TPS-RX110AY-Plus: **Admin**

Active timeout is elapsed, so the values of the Active- prefixed properties are deleted.

Rx	RxHex	Hash	ActiveRx	ActiveRxHex	ActiveHash
Login:	4C6F67696E3A	2D8A5E38			

◀ VC codec: **Password:**

Rx	RxHex	Hash	ActiveRx	ActiveRxHex	ActiveHash
Password:	50617373776F72643A	79059B26	Password:	50617373776F72643A	79059B26

▶ HDMI-TPS-RX110AY-Plus: **Admin**

Active timeout is elapsed, so the values of the Active- prefixed properties are deleted.

Rx	RxHex	Hash	ActiveRx	ActiveRxHex	ActiveHash
Password:	50617373776F72643A	79059B26			

5.7.2. Relays

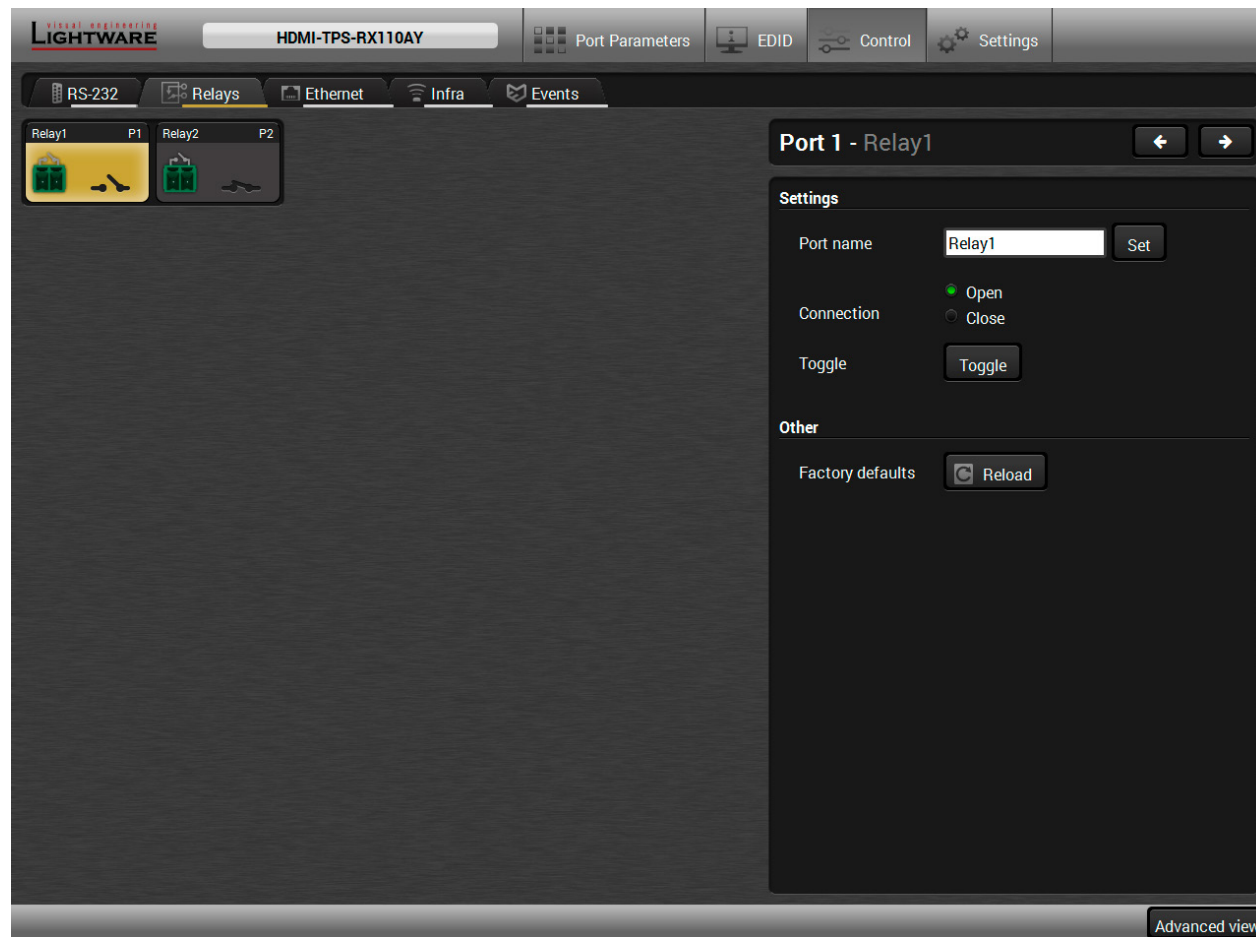

Relays tab in Control menu

Two relays are built into the HDMI-TPS-RX110AY receiver. The following settings are available for both relay ports:

- Connection state: Open or Close;
- Toggle;
- Reloading factory defaults (see factory default settings in the [Factory Default Settings](#) section).

`#relay_ldc`

5.7.3. Ethernet

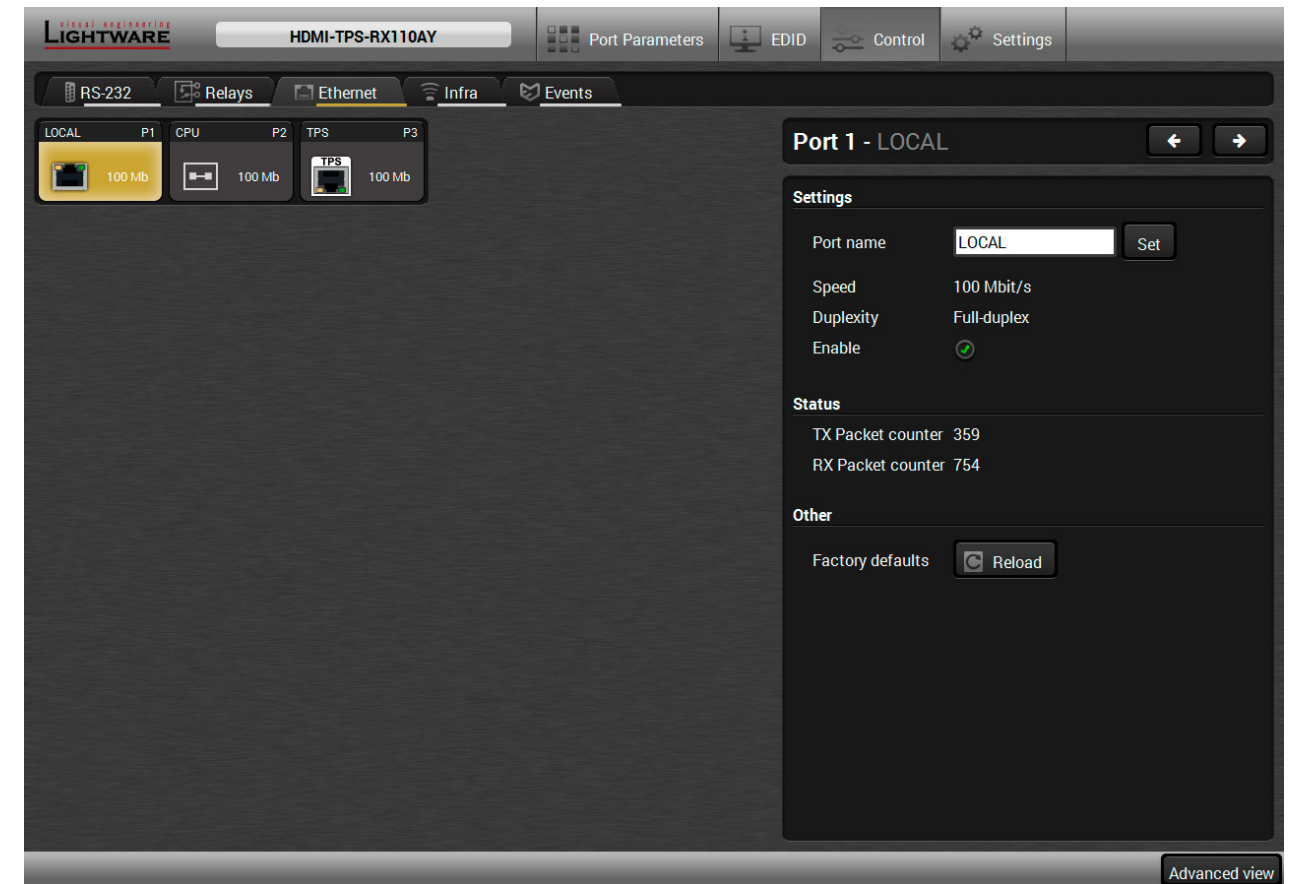

Ethernet tab in Control menu

Three ports are displayed in the Ethernet settings: Local, CPU, and TPS. You can check the status of the Ethernet line by each ports: the speed and the duplexity of the connection.

The following settings are available for each ports:

- Enable / disable the port; *
- Reloading factory defaults (see factory default settings in the [Factory Default Settings](#) section).

* CPU Ethernet port cannot be disabled.

`#ethernet_ldc`

5.7.4. Infra

ATTENTION! The device has no built-in Infrared receiver and transmitter. For the complete usage attach an IR emitter unit to the IR OUT and an IR detector unit to the IR IN connectors.

Infrared (IR) receiver and transmitter options can be found on this tab. There are three submenus available under it: **IR codes**, **Ports**, and **Clear all IR codes**.

IR Codes

User can set the name of the IR code, the fingerprint (hash), and the repeat timeout in ms, as well as actions can be ordered to each IR codes.

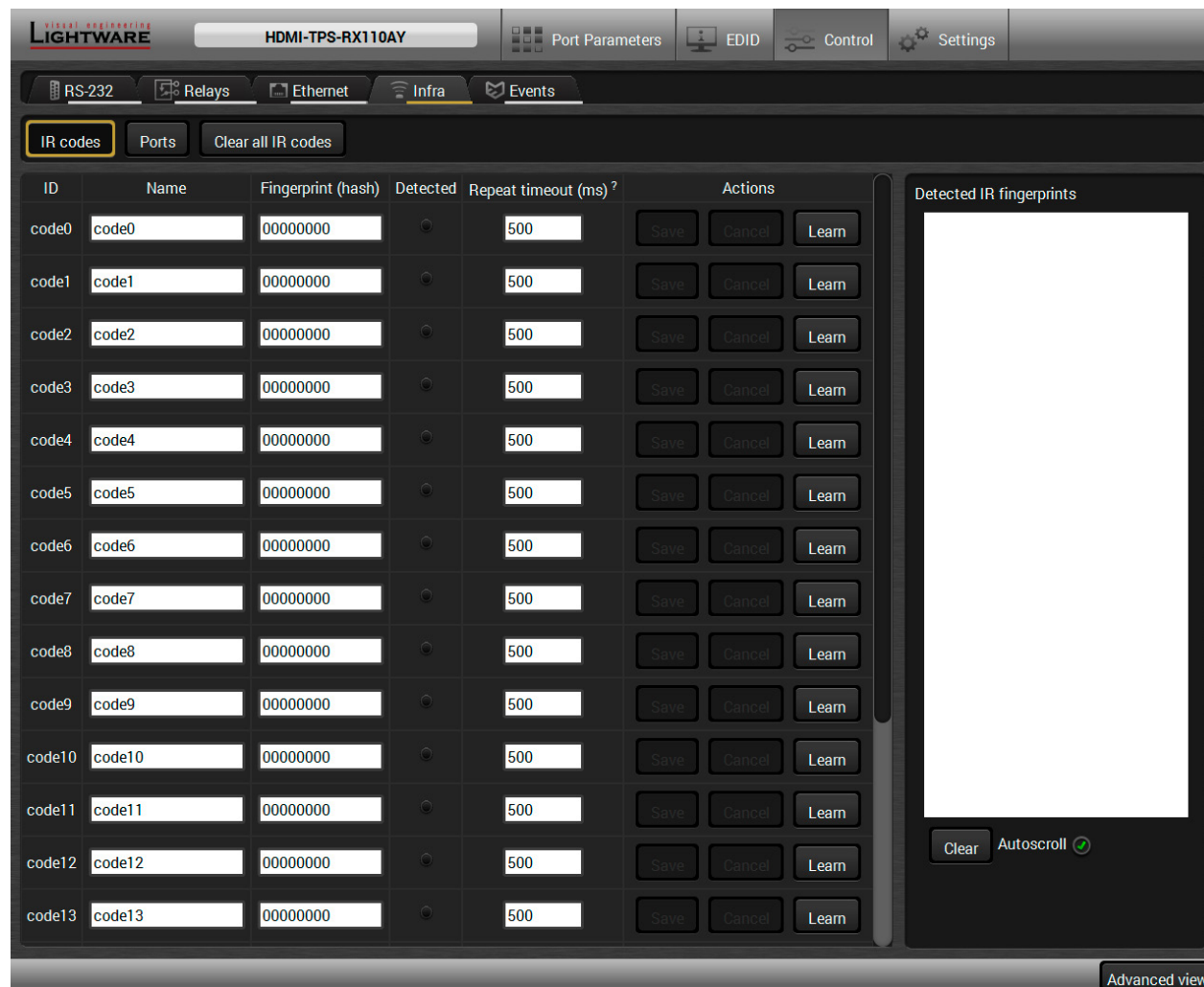

IR codes window in Control menu

Description	Function
ID	Code number.
Name	You can give an unique name for the desired code.
Fingerprint (hash)	Fingerprint code in pronto hexa format.
Detected	Indicator gives feedback about the given IR code is detected currently.
Repeat timeout (ms)	You can set a timeout to avoid the involuntary code recurrence.
Actions	Action buttons for the desired IR code: Save: saving the fingerprint. Cancel: canceling the fingerprint. Learn: learning the detected IR code.
Detected IR fingerprints	You can check the detected IR codes in this panel. Pushing Clear button deleting all current fingerprints and switch on or off the automatic scrolling with the Autoscroll pipe.

20 fingerprints can be stored in the device at the same time. Each of them can be ordered to an action in Event Manager. For more details about events see [Event Manager](#) section.

Learning IR Codes

Step 1. Connect the IR detector unit to the IR IN port of the receiver.

Step 2. Click on the **Learn** button.

Step 3. Turn the remote controller to the IR detector. A pop-up window appears in LDC - press your remote button to learn.

Step 4. Once the code is received, a new window pops up in LDC - learning completed. Click **OK** to continue.

Step 5. Optionally type a unique name for the code in the **Name** text box. The default name is code#, e.g. code0.

#infra_ldc #infrared_ldc

Ports Section for the HDMI-TPS-RX110AY Model

User can set the name and command injection port to each sources and destinations. For more details about IR interface see the [IR Interface](#) section.

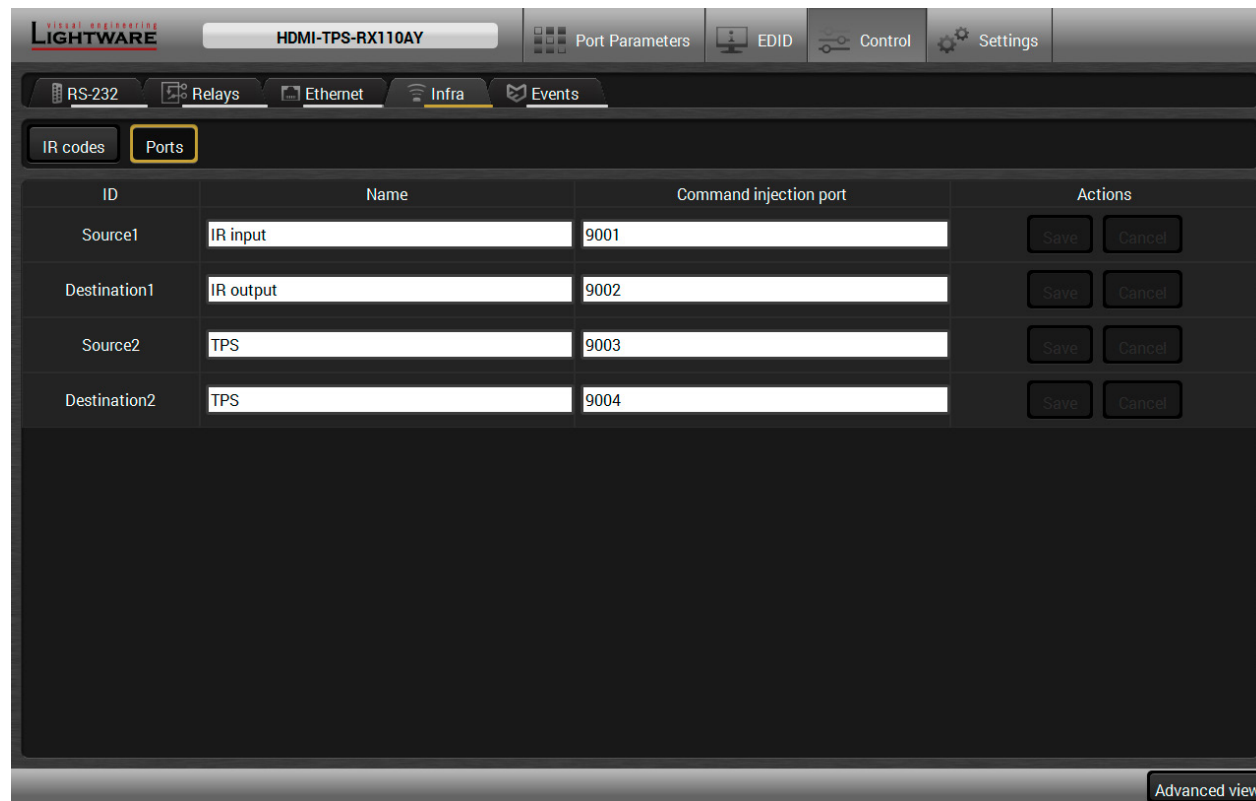

Infra tab - Ports window

Clear all IR codes

Clicking on the button results deleting all stored IR fingerprints.

Ports Section for the HDMI-TPS-RX110AY-Plus Model

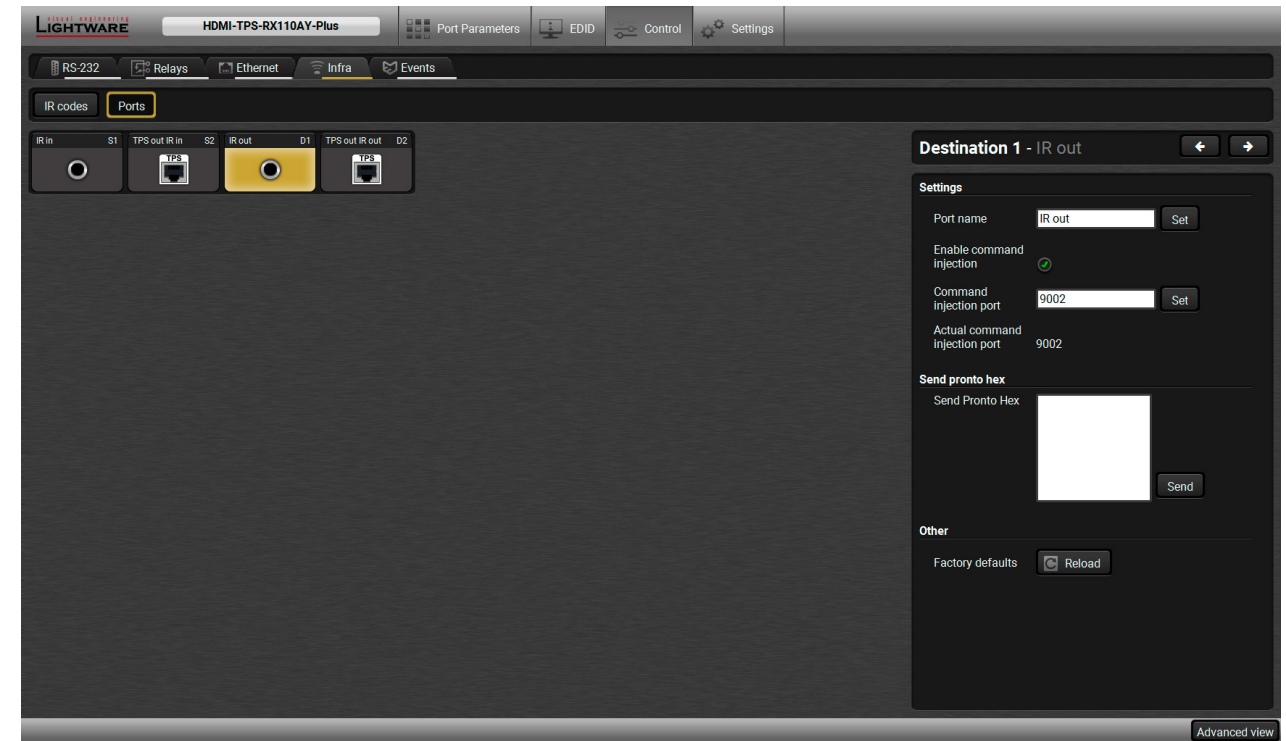

Infra tab - Ports window for the HDMI-TPS-RX110AY-Plus model

The user can set the name and command injection port to each sources and destinations. For more details about IR interface see the [IR Interface](#) section.

The following settings are also available:

- Port name;
- Enable / disable the port;
- Port number;
- Enable / disable command injection;
- Message sending function (little-endian pronto hex code). For more details see the next section;
- Reload [Factory Default Settings](#).

Sending pronto hex codes (Little-endian format)

Copy the raw, little endian-format IR code into the **Send Pronto Hex** entry field and click the **Send** button.

The maximum length of the code can be 765 characters (765 bytes). For more details about the accepted IR code formats, see [Sending Pronto Hex Codes in Little-endian Format via IR Port](#) section.

This entry field does not store the code. The code can be saved into the action in the event manager with the following parameters: **Category:** Infra; **Expression:** Send pronto hex; **Port:** D1; **Pronto hex:** <custom_code>

In the Event Manager, the maximum length of the code can be 184 characters (184 bytes). *#message_idc #new*

INFO: Sending bigger endian-format code is available with LW3 protocol command, see [Sending Pronto Hex Codes in Big-endian Format via IR Port](#) section.

Clear all IR codes

Clicking on the button results deleting all stored IR fingerprints.

5.8. Event Manager

The feature means that the device can sense changes on its ports and able to react according to the pre-defined settings. The development idea of the Event manager is based on users' feedbacks. In many cases internal events (such as signal present or HDCP active) are necessary to display but it is not easy when the device is hard to access (e.g. built under the desk). For more details and examples about Event Manager please visit our website (www.lightware.com) and download **Event Manager user's guide** in the Downloads section.



The Event manager can be configured to perform an action if a condition has been detected. E.g. the desired setup is that after a certain type of signal has been detected on I1 port, the port has to be switched to O1. The settings can be done via the LDC in the Control/Events tab, or by LW3 protocol commands. Configurable events number depends on the device what you are using actually.

Numerous new ideas and requests have been received in connection with the features and settings of the Event manager since the first release. Therefore, the user interface has been re-designed and many new functions implemented. The Event editor can be opened by pressing the Edit button at each Event.

There is a **grey bar** on the left of the Event panel in each line. If a condition and an action are set and the Event is enabled, the bar is displayed in **green**.

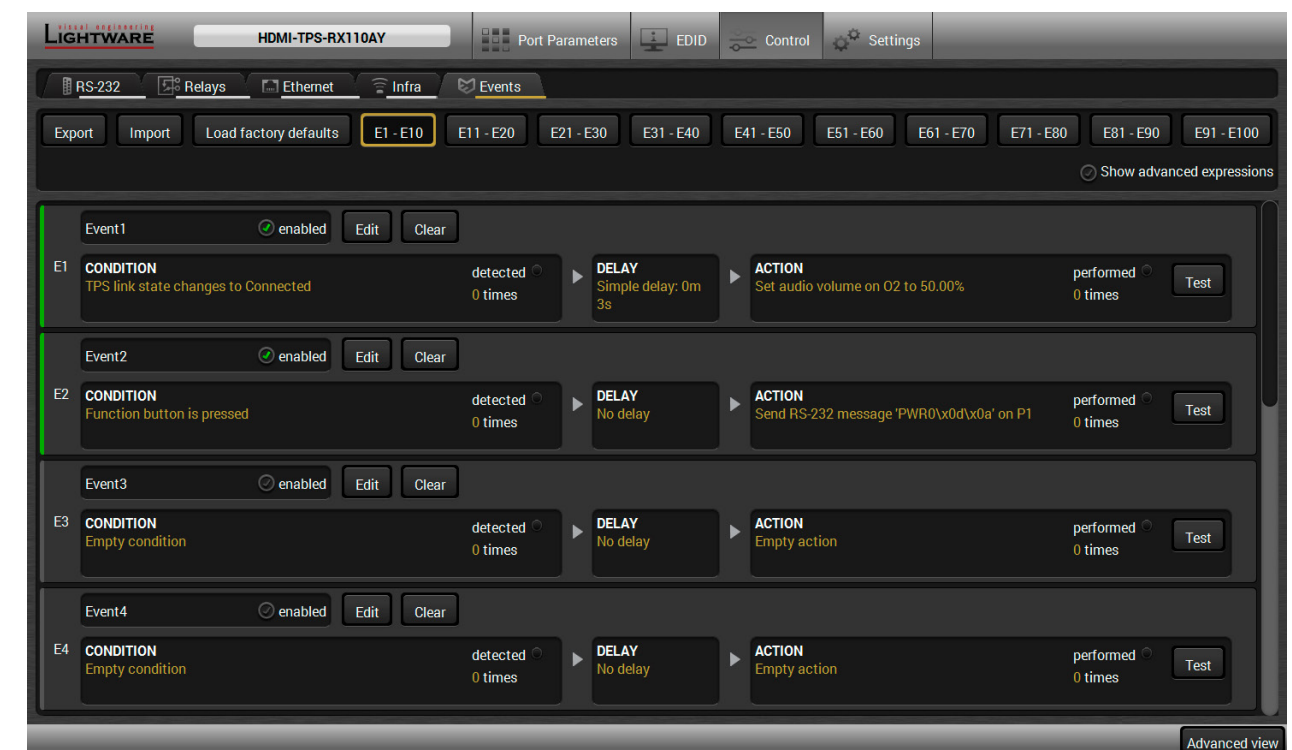

Control menu, Event Manager tab

#eventmanager_idc

5.8.1. The Event Editor

Press the **Edit** button in the desired Event line to open the Event editor window.

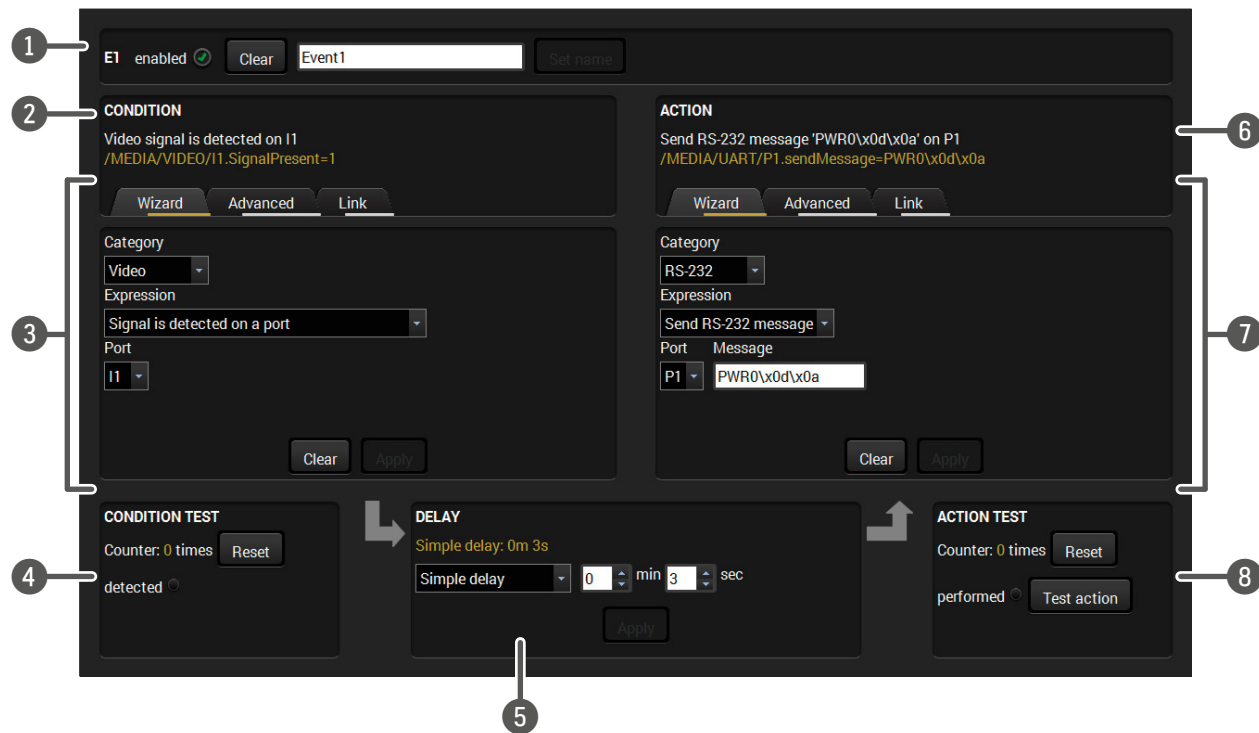

- 1 **Event header** The name of the Event is displayed. Type the desired name and press the Set name button. The Event can be cleared by the Clear button. Use the tick mark to enable/disable the Event.
- 2 **Condition header** If the condition is set, the description (white colored text) and the exact LW3 protocol expression (yellow colored text) can be seen. If the advanced mode was used the description is "Custom condition".
- 3 **Condition panel** The Wizard, the Advanced or the Link tool is available to set the condition. The parameters and settings are displayed below the buttons.
- 4 **Condition test** The set condition can be tested to see the working method in the practice.
- 5 **Delay settings** The action can be scheduled to follow the condition after the set time value.
- 6 **Action header** If the action is set, the description (white colored text) and the exact LW3 protocol expression (yellow colored text) can be seen. If the advanced mode was used the description is "Custom action".
- 7 **Action panel** The Wizard, the Advanced or the Link tool is available to set the action. The parameters and settings are displayed below the buttons.
- 8 **Action test** The set action can be tested to see the working method in the practice.

5.8.2. Create or Modify an Event

Wizard Mode

The wizard mode lists the most common conditions and actions, so the user does not have to look for LW3 nodes and properties.

- Step 1. Click on the **Edit** button of the desired Event; the **Event editor** is displayed.
- Step 2. The wizard mode is displayed as default. Select the desired **Category** first (e.g. Audio or Video).
- Step 3. Select the desired **Expression** from the drop-down menu. If any other parameter is necessary to set, it is going to be displayed.
- Step 4. Press the **Apply** button to store the settings of the Condition.

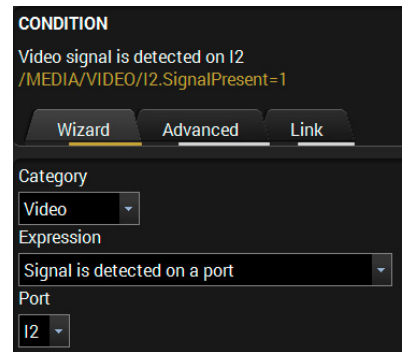

Advanced Mode

The goal of this mode is the same as of the wizard: set the properties and methods for conditions and actions. The difference is the number of the available and usable properties and methods of the LW3 protocol. Advanced mode allows almost all of it.

- Step 1. Click on the **Edit** button of the desired Event; the **Event editor** is displayed.
- Step 2. The wizard mode is the default, press the **Advanced** button. The LW3 protocol tree is displayed showing the list of the properties in the drop-down menu. Navigate to the desired node.
- Step 3. Select the desired **Property** from the menu. The **manual** of the property is displayed below to help to select the necessary property and to set the value.
- Step 4. Set the desired **value** and **operator**, then press the **Apply** button to store settings.

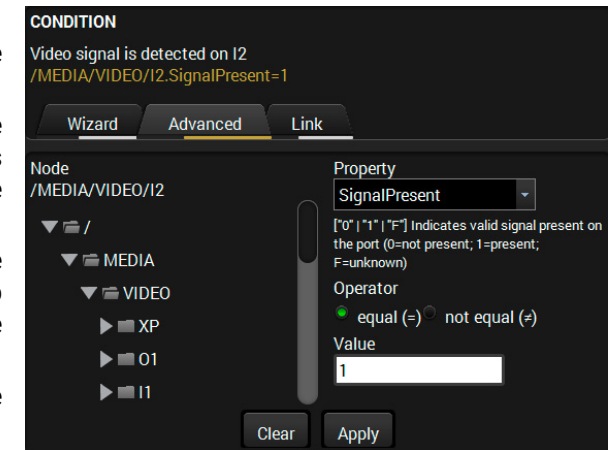

The Link Tool

The new interface allows creating more actions to the same condition. In that case, a condition can trigger more actions. To set such an Event, the Link tool has been introduced.

- Step 1. Click on the **Edit** button of the desired Event; the **Event editor** is displayed.
- Step 2. The wizard mode is displayed as default, press the **Link** button.
- Step 3. All the saved Events are analyzed and the **conditions** are listed (it takes some seconds to finish). The **Show advanced expressions** option allows showing the exact path and set the value of the given property.
- Step 4. Select the desired **Condition** and press the **Apply** button to store the settings.

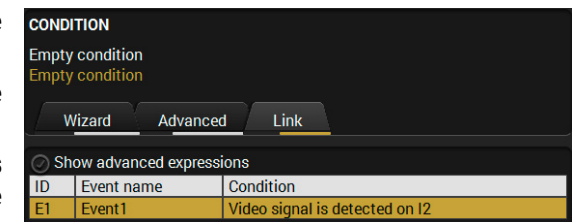

5.8.3. Special Tools and Accessories

The Name of the Event

The name of a port can be changed by typing the new name and clicking the **Set** button. The following characters are allowed when naming:

Letters (A-Z) and (a-z), numbers (0-9), special characters: hyphen (-), underscore (_), and space ().

Enable or Disable an Event

The set Event can be enabled or disabled in the Event list, or directly in the Event editor window by setting the **tick mark** beside the name.

Testing the Condition

When the desired Condition is arranged, the setting can be tested. The Event list and the Event editor contains a small panel that shows if the set condition is detected and how many times. The **Counter** can be reset by the button in Event editor. If the Condition is true, the **detected** mark turns green for two seconds and the **Counter** is increased.

Testing the Action

The method is the same as testing the Condition, but in this case, the Action can be triggered manually by pressing the **Test** button.

TIPS AND TRICKS: The Test button is also placed on the Action panel in the Event list. Thus, you can check the Actions without opening the Event editor.

Delay the Action

In most cases the Action is performed immediately after the Condition is detected. But sometimes a delay is necessary between the Condition and the Action. Therefore, the new Event manager contains the Delay panel which allows that feature with below settings:

- **No delay:** when the Condition is detected, the Action is launched.
- **Simple delay:** when the Condition is detected, the Action is launched after the set time interval.
- **Still exists:** when the Condition is detected, the Action is launched after the set time interval only if the Condition still exists.
- **Continuously exists:** when the Condition is detected, the Action is launched after the set time interval only if the Condition has been existing continuously.

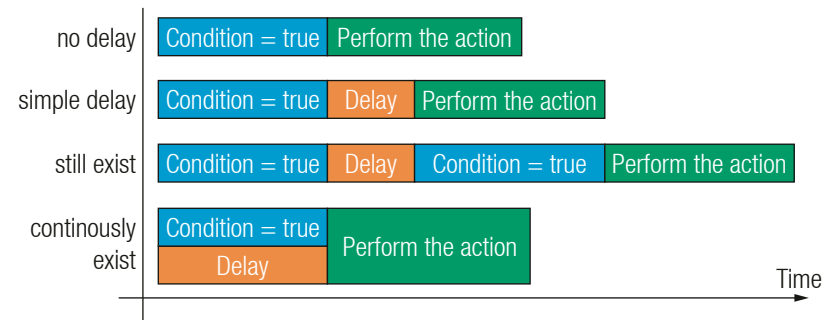

The available delay settings of an Event

TIPS AND TRICKS: **Show advanced expressions** option is a useful tool when you look for the path or value of a property but just the expression is displayed. The option is available in the Event list window or when Link tool is used.

5.8.4. Clear One or More Event(s)

Clear an Event

Press the **Clear** button in the Event list or in the header section in the Event editor.

Clear all Events

When all the Events must be cleared press the **Load factory defaults** button above the Event list. You will be prompted to confirm the process.

5.8.5. Export and Import Events

The feature allows saving all the Events. The backup file can be uploaded to another HDMI-TPS-RX110AY receiver.

Export all the Events

Step 1. Press the **Export** button above the Event list.

Step 2. The Save as dialog box will appear. Set the desired folder and file name, then press the **Save** button.

The generated file is a simple text file which contains LW3 protocol commands. The file can be viewed by a simple text editor, e.g. Notepad.

ATTENTION! Editing the file is recommended only for expert users.

Import all the Events

Step 1. Press the **Import** button above the Event list.

Step 2. The Open dialog box will appear. Select the desired folder and file, then press the **Open** button.

5.8.6. Event Creating - Example

The following example shows you on a real-life situation how to set up an Event.

The Concept

The HDMI-TPS-RX110AY receiver is connected to a projector by the HDMI output port. The receiver is also connected to the projector by the RS-232 port and can send commands via the serial line.

The task is to turn on the projector when signal is detected on the HDMI output port.

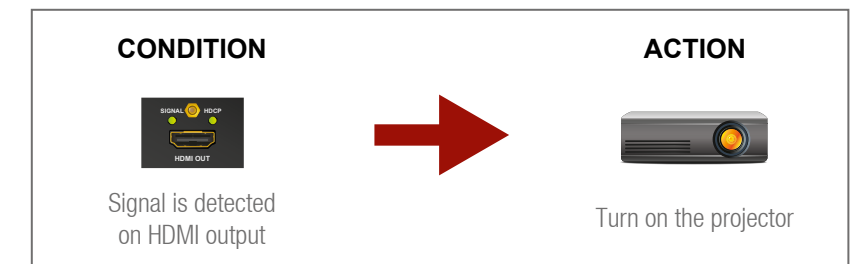

RS-232 Settings

Make sure that the serial line is established between the receiver and the projector. Check that the RS-232 settings of the receiver is set exactly the same which required for the projector: baud rate, data bits, parity, stop bits. The receiver needs to be set to: Control protocol: LW3; and RS-232 mode: Pass-through. See the relevant LDC settings in the [RS-232](#) section.

Setting the Event

You can create the Event in the Wizard in few simple steps:

Step 1. Set the condition.

Select the required parameters to set the condition:

- **Category:** Video;
- **Expression:** Signal is detected on a port;
- **Port:** O1.

Click on the **Apply** button to complete the procedure. When it is done, the condition appears on the upper side in textual and LW3 command format as well.

Step 2. Set the action.

If the condition is fulfilled, the following action needs to be launched: the receiver sends a command to the projector over the serial line:

- **Power on** - the required command which is accepted by the projector: PWR0<CR><LF>

For this instance the command has to be closed with the <CR><LF> characters so they need to be escaped. You can use the following format for escaping:

```
<command1><\x0d\x0a><command2><\x0d\x0a>...
...<commandn><\x0d\x0a>
```

In the current case the command is: PWR0\x0d\x0a

Select the required parameters to set the action:

- **Category:** RS-232;
- **Expression:** Send RS-232 message;
- **Port:** P1;
- **Message:** PWR0\x0d\x0a

Step 3. Enable the Event.

Select the **E1 enabled** pipe in upper left corner to set the Event as launched.

INFO: If you do not find the required category/expression/etc what you need, choose the Advanced mode in the Wizard where the entire LW3 structure tree is available. For example instead of signal detection you can set a specified resolution or color range either as a condition.

CONDITION
Video signal is detected on O1
/MEDIA/VIDEO/O1.SignalPresent=1

Wizard Advanced Link

Category: Video

Expression: Signal is detected on a port

Port: O1

Clear Apply

ACTION
Send RS-232 message 'PWR0\x0d\x0a' on P1
/MEDIA/UART/P1.sendMessage=PWR0\x0d\x0a

Wizard Advanced Link

Category: RS-232

Expression: Send RS-232 message

Port: P1 Message: PWR0\x0d\x0a

Clear Apply

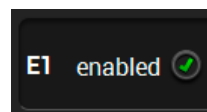

5.9. Settings Menu

5.9.1. Status

HDMI-TPS-RX110AY-Plus

Port Parameters EDID Control Settings

Status Network Front Panel Backup System

General

Product name	HDMI-TPS-RX110AY-Plus
MAC address	a8:d2:36:00:43:12
Hardware version	V11_BAA0
Device label	HDMI-TPS-RX110AY-F Set
Part number	91540070
Serial number	00004312

Built-in miniweb

Open miniweb **Open miniweb**

Upload built-in miniweb **Choose file**

Actual file size 0 bytes

Max file size limit 1048576 bytes

Clear built-in miniweb **Clear**

Identify device

Identify me **Identify me**

Operation

System uptime	0 days 01h 52m 31s
Operation time	0 days 21h 42m 23s
High temp operation time	0 days 00h 00m 00s

Firmware versions

CPU firmware version	1.3.5b3 r61
TPS in firmware version	1.1.0b0 r63

Temperatures

CPU temperature	56 °C (26 °C min, 60 °C max)
System temperature	56 °C (26 °C min, 60 °C max)

Voltages

12 V local	12.13 V (12.11 V min, 12.25 V max)
5 V main	5.04 V (5.02 V min, 5.05 V max)
3.3 V main	3.39 V (3.37 V min, 3.4 V max)
3.3 V audio DAC	3.3 V (3.29 V min, 3.31 V max)
1.8 V TPS	1.85 V (1.85 V min, 1.86 V max)
1.3 V main	1.31 V (1.31 V min, 1.32 V max)
1 V TPS	1 V (0.99 V min, 1.01 V max)

Advanced view

Status tab in Settings menu

The most important hardware and software related information can be found on this tab: hardware and firmware version, serial numbers, temperatures, operation time, and voltage information. Device label can be changed to unique description by the **Set** button.

Built-in Miniweb

The built-in website makes possible to connect to the device, and query status information with a web browser. System requirements for operating systems: Microsoft Windows XP, Windows Vista, Windows 7, Windows 10, macOS, Linux. Compatible web browsers: Mozilla Firefox, Google Chrome, Apple Safari.

ATTENTION! Please be sure that the computer is in the same network as the HDMI-TPS-RX110 series device. If the computer has multiple Ethernet connections (for example Wi-Fi and LAN connections are used simultaneously) you will have to know the IP address for the one, that is used for controlling the receiver.

The built-in website can be easily reached by clicking the **Open the miniweb** button (or write the IP address of the device in the search bar of the web browser).

The .html file of the built-in web can be changed by clicking on **Choose file** button. Clicking on the Reset button restores the default .html file. #miniweb #firmwareversion_Idc #status_Idc #devicelabel_Idc #label_Idc

Identify Me Feature

Clicking on the **Identify me** button results the blinking of the status (in green) for 10 seconds. The feature helps to identify the device itself in the rack shelf. `#identifyme_idc`



5.9.2. Network

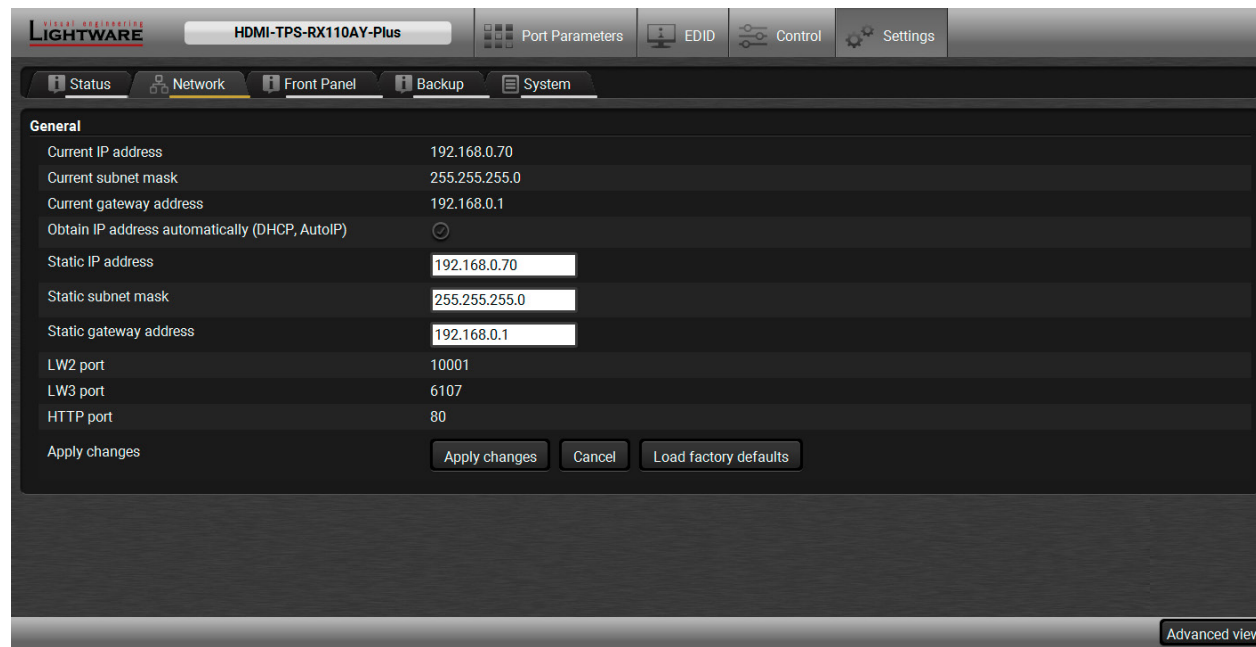

Network tab in Settings menu

IP address and DHCP settings can be set on this tab. Always press the **Apply settings** button to save changes. Factory defaults settings can be recalled with a dedicated button. `#network_idc #dhcp_idc #ipaddress_idc`

5.9.3. Front Panel

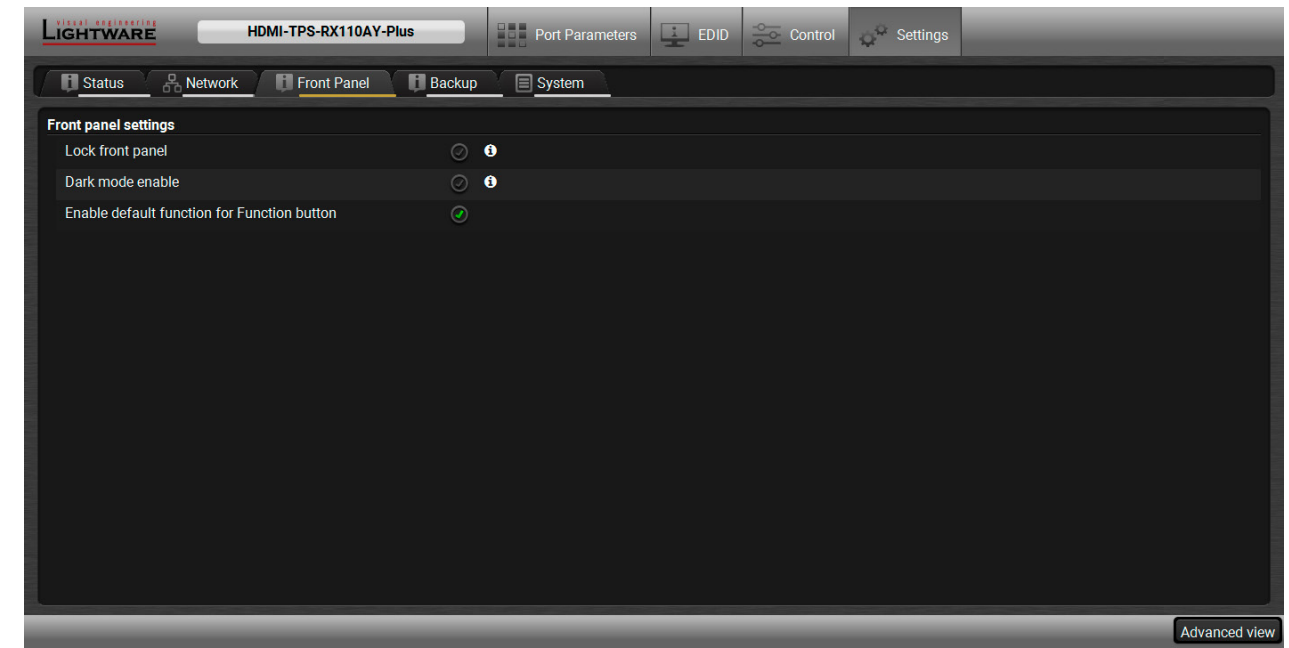

Front panel tab in Settings menu

Available settings:

- **Lock front panel:** the Function button functionally can be disabled with the option is marked.
- **Dark mode enable:** when dark mode is enabled, all status LEDs are switched off after one minute, if no button pressed. Pressing the Function button brings back status info on the LEDs without performing the function of the button itself.
- **Enable default function for Function button:** enabling the option results the default function of the Function button is enabled.

`#buttonlock_idc #lockbutton_idc #darkmode_idc #new`

5.9.4. Backup

Details about this function can be found in the [Configuration Cloning \(Backup Tab\)](#) section.

5.9.5. System

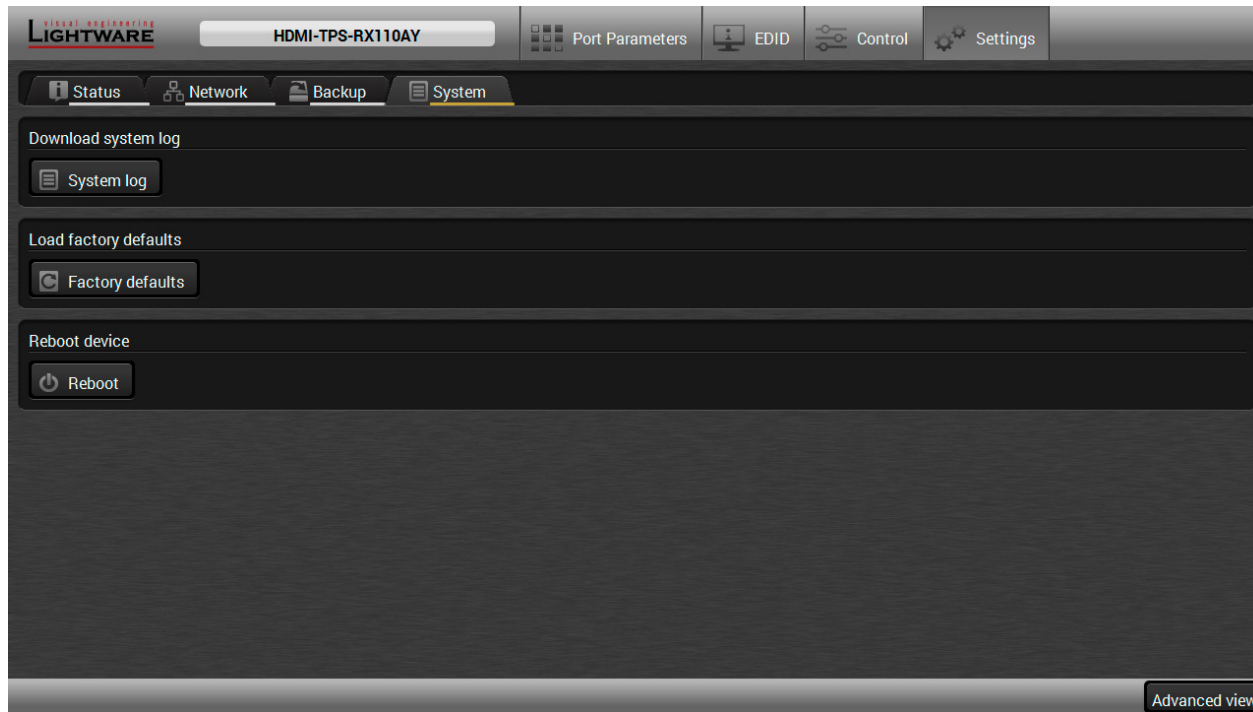

System tab in Settings menu

Three functions are available under System tab:

- **Download system log** - saving the file of the device.
- **Load factory defaults** - recalling factory defaults settings and values. All factory default settings are listed in the [Factory Default Settings](#) section.
- **Reboot** - rebooting the system.

`#log_ldc #systemlog_ldc #factory_ldc #restart_ldc #reboot_ldc`

5.10. Configuration Cloning (Backup Tab)

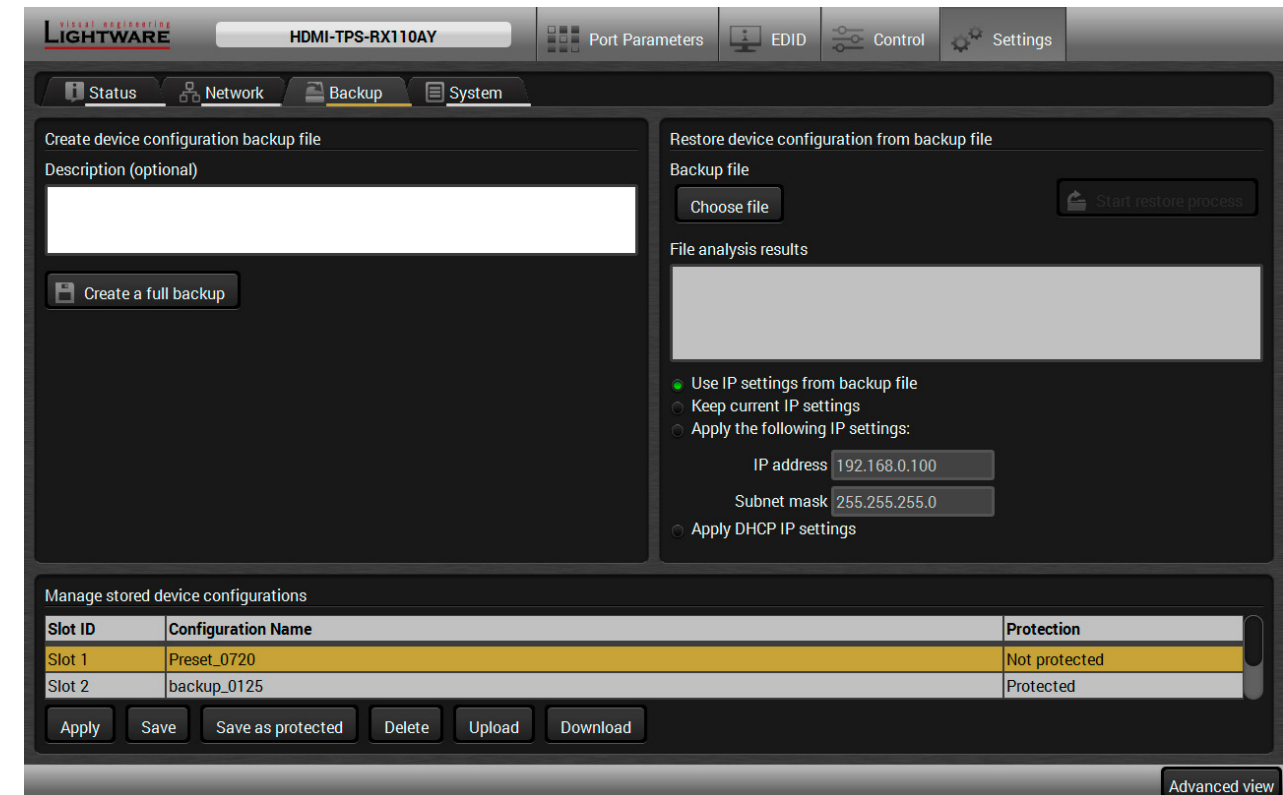

Backup tab

The configuration cloning of Lightware LW3 devices is a simple method that eliminates the need to repeatedly configure certain devices to have identical (non-factory) settings. If the devices are installed in the same type of system multiple times then it is enough to set up only one device to fit the user's needs and then copy those settings to the others, thus saving time and resources.

5.10.1. Cloning Steps in a Nutshell

Installing multiple devices with the same customized configuration settings can be done in a few easy steps:

Step 1. Configure one device with all your desired settings with the LDC software.

Step 2. Backup the full configuration file to your computer.

Step 3. If needed, make some modifications to the configuration file using a text editor (e.g. Notepad). E.g. modifying the static IP address is needed when DHCP is not used.

Step 4. Connect to the other device which has to be configured and upload (restore) your configuration file.

Step 5. Done! You can have as many totally identical, customized devices as you like.

`#backup_ldc #configurationcloning_ldc`

5.10.2. Save the Settings of the Device (Backup)

- Step 1.** Apply the desired settings in the transmitter (port parameters, crosspoint, etc.)
- Step 2.** Select the **Settings / Backup** tab from the menu.
- Step 3.** Write a short **description** in the text box on the left (optional).
- Step 4.** Press the **Create a full backup** button. You will be prompted to save the file to the computer. The default file name is the following:

```
BACKUP_<DEVICE TYPE>_SN<SERIAL NUMBER>.LW3
```

- Step 5.** Set the desired **file name**, select the folder and **save** the file.

TIPS AND TRICKS: Using the exact product type in the filename is recommended since it makes the file usage more comfortable.

About the Backup File

The backup file is a simple text file which contains LW3 protocol commands. The first line is the description, and the further lines are the commands which will be executed during the restore process. The file can be viewed (and/or edited) by a simple text editor, e.g. Notepad.

ATTENTION! Editing the command lines is only recommended for expert users.

See the entire list of saved data in the [Content of Backup File](#) section.

5.10.3. Upload the Settings to a Device (Restore)

WARNING! WARNING!: Please note that the settings will be permanently overwritten with the restored parameters in the device. Withdrawal is not possible.

ATTENTION! ATTENTION! The cloning is successful when the backup file is downloaded from the same type of source device as the destination device.

The Restoring Process

- Step 1.** Select the **Settings / Backup** tab from the menu.
- Step 2.** Click on the **Choose file** button on the right panel and **browse** the desired file.
- Step 3.** The file is checked and the result will be displayed in the textbox below. If the file is correct, the settings can be restored.
- Step 4.** Choose **IP settings** what you want to use after backup. You can apply settings from the backup file, keep actual settings, set it manually in a dialog box or apply DHCP.
- Step 5.** Press the **Start restore process** button and click on the **Yes** button when asked.
- Step 6.** Reboot the device to apply the network settings after finishing.

5.10.4. Create and Restore Backups from the Device Memory

HDMI-TPS-RX110AY series receivers are able to store backups in its own memory and can be recalled from there so user does not need to save backup files to the local computer. Four slots are available for this purpose.

Manage stored device configurations		
Slot ID	Configuration Name	Protection
Slot 1	Preset_0720	Not protected
Slot 2	backup_0125	Protected
Slot 3	<Empty slot>	Not protected
Slot 4	<Empty slot>	Not protected

Apply Save Save as protected Delete Upload Download

You can save presets as not protected with using **Save** button and as protected with using the **Save as protected** button. Restoring a preset select on the slot of the desired backup and click on the **Apply** button. You can save presets from a file from your local computer clicking on the **Upload** button and you can also save a preset from the device's memory to a backup file with using the **Download** button. If you do not need a saved preset any more, select it and click on the **Delete** button.

WARNING! Loading factory default settings will erase all presets which has been saved in the device memory!

5.11. Advanced View Window

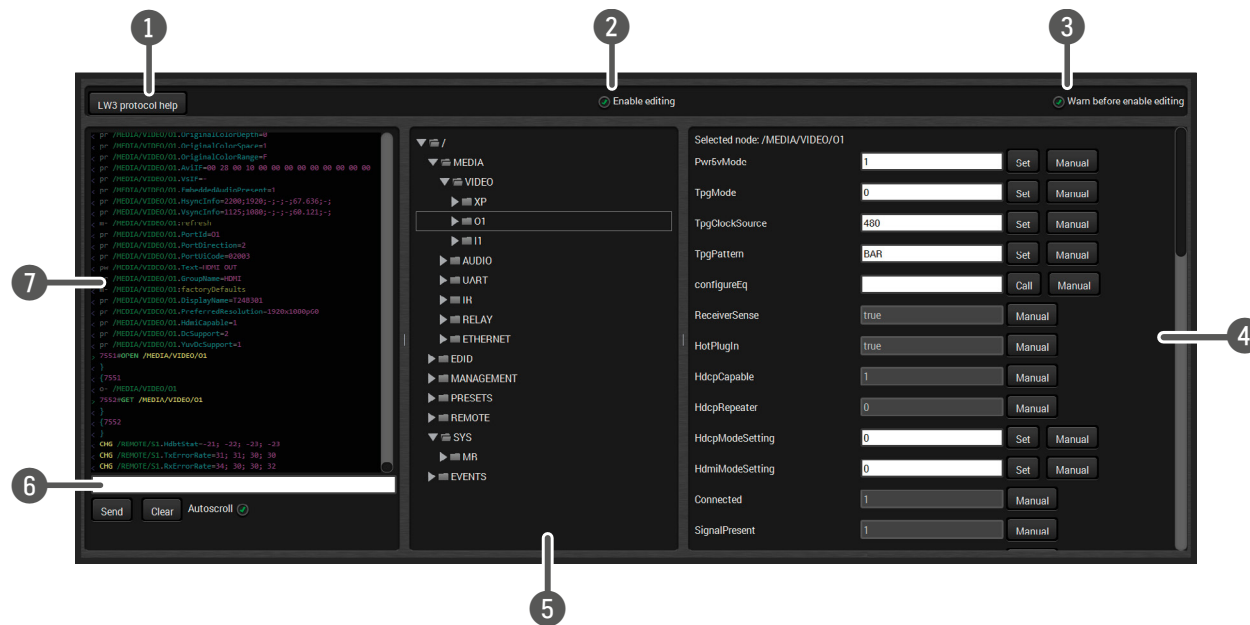

- 1 **LW3 protocol help** Pushing the button results a help window opening which describes the most important information about LW3 protocol commands in HTML format.
- 2 **Edit mode** The default appearance is the read-only mode. If you want to modify the values or parameters, tick the option. You will be prompted to confirm your selection.
- 3 **Warning mode** If this pipe checked in, a warning window pops up when you enable Edit mode.
- 4 **Node list** Correspondent parameters and nodes are shown which are connected to the selected item in the protocol tree.
Manual button: Manual (short description) of the node can be called and displayed in the terminal window.
Set button: Saves the value/parameter typed in the textbox.
Call button: Calls the method, e.g. reloads factory default settings.
- 5 **Protocol tree** LW3 protocol tree; select an item to see its content.
- 6 **Command line** Type the desired command and execute it by the **Send** button. Clear all current commands and responses in the Terminal window by the **Clear** button.
- 7 **Terminal window** Commands and responses with time and date are listed in this window. Sent command starts with '>' character, received response starts with '<' character. The color of each item depends on the type of the command and response. The content of the window can be emptied by the **Clear** button. If the **Autoscroll** option is ticked, the list is scrolled automatically when a new line is added.

#terminal_ldc #advancedview_ldc

6

LW2 Programmers' Reference

The device can be controlled through a reduced command set of LW2 protocol commands to ensure the compatibility with other Lightware products. The supported LW2 commands are described in this chapter.

- ▶ LW2 PROTOCOL DESCRIPTION
- ▶ GENERAL LW2 COMMANDS
- ▶ PORT SETTINGS
- ▶ NETWORK CONFIGURATION
- ▶ RS-232 SETTINGS
- ▶ RELAY SETTINGS
- ▶ LW2 COMMANDS – QUICK SUMMARY

6.1. LW2 Protocol Description

The device accepts commands surrounded by curly brackets - {} - and responds data surrounded by round brackets - () - only if a command was successfully executed.

Format	Explanation
<in>	Input number in 1 or 2 digit ASCII format (01, 5, 07, 16, etc.)
<out>	Output number in 1 or 2 digit ASCII format
<in ² >	Input number in 2 digit ASCII format (01, 02, 10, 12 etc.)
<out ² >	Output number in 2 digit ASCII format (01, 02, 10, 12 etc.)
<loc>	Location number in 1, 2 or 3 digit ASCII format
<id>	id number in 1 or 2 digit ASCII format
<id ² >	id number in 2 digit ASCII format
CrLf	Carriage return, Line feed (0x0D, 0x0A)
.	Space character (0x20)
→	Each command issued by the controller
←	Each response received from the router

6.2. General LW2 Commands

6.2.1. View Product Type

Description: The device responds its name. *#producttype_lw2*

Format	Example
Command {} Response (I:<PRODUCT_TYPE>)CrLf	→ {} ← (I:HDMI-TPS-RX110AY)

Explanation: The connected device is a HDMI-TPS-RX110AY.

Legend: <PRODUCT_TYPE> shows type.

6.2.2. Query Control Protocol

Description: The device can be controlled with different control protocols. This command queries the active protocol of the currently used control interface. *#protocol_lw2*

Format	Example
Command {P_?} Response (CURRENT·PROTOCOL·=#<protocol>) CrLf	→ {P_?} ← (CURRENT PROTOCOL = #1)

Explanation: The device communicates with LW2 protocol.

6.2.3. View Firmware Version of the CPU

Description: View the CPU firmware revision. *#firmwareversion_lw2*

Format	Example
Command {F} Response (FW:<FW_VER><s>)CrLf	→ {f} ← (FW:1.3.1b6)

Legend: <FW_VER> is the firmware version. It is followed by <s> string which may indicate special versions.

6.2.4. Connection Test

Description: Simple test to see if the connection is established successfully.

Format	Example
Command {PING} Response (PONG!)CrLf	→ {ping} ← (PONG!)

6.2.5. View Serial Number

Description: The device responds its 8-digit serial number.

Format	Example
Command {S} Response (SN:<SERIAL_N>)CrLf	→ {s} ← (SN:5A004254)

6.2.6. Compile Time

Description: Returns the date, when the CPU firmware was compiled.

Format	Example
Command {CT} Response (Complied: <DATE&TIME>)CrLf	→ {ct} ← (Compiled: Sep 30 2016 14:07:56)

6.2.7. View Installed Board

Description: Shows the hardware name and revision of the installed cards.

Format	Example
Command {IS} Response (SL# 0·<MB_DESC>)CrLf (SL·END)CrLf	→ {is} ← (SL# 0 HDMI-TPS-RX110AY V12) ← (SL END)

Explanation: The device reports its motherboard (slot 0).

6.2.8. View Firmware for All Controllers

Description: Shows the firmware versions of all installed controllers. *#firmwareversion_lw2*

Format	Example
Command {FC} Response (CF·<DESC>)CrLf (CF·<DESC>)CrLf ... (CF END)CrLf	→ {fc} ← (CF HDMI-TPS-RX110AY 1.3.1b6) ← (SL END)

Explanation: The device has one control panel.

6.2.9. Restart the Device

Description: The device can be restarted without unplugging power. *#restart_lw2 #reboot_lw2*

Format	Example
Command {RST} Response	→ {RST}

Explanation: The device reboots; no response is sent in this case.

6.2.10. Query Health Status

Description: Internal voltages and measured temperature values are shown. *#status_lw2*

Format	Example
Command {ST} Response (ST·<DESC>)CrLf	→ {ST} ← (ST CPU 0.09V 12.13V 5.03V 3.31V 3.32V 3.39V 1.85V 1.31V 1.00V 42.46C 42.55C)

6.2.11. Restore Factory Default Settings

Description: Settings can be reset to factory default values as follows:

Format	Example
Command {FACTORY=ALL} Response (FACTORY ALL...)CrLf	→ {factory=all} ← (FACTORY ALL...)

Explanation: All settings and parameters are reset to factory default, see the table in the [Factory Default Settings](#) section. *#factory_lw2*

6.3. Port Settings

6.3.1. Mute Output

INFO: <A/V/AV> option usually can be skipped for legacy purposes. In this case, the devices change all (Video & Audio) layers but using status commands it displays information about only the Video layer. Please use AV option, when available.

Description: Mute output <out>. The output signal is turned off. *#mute_lw2*

Format	Example
Command {#<out>·<layer>} Response (1MT<out²>·<layer>)CrLf	→ {#1 AV} ← (1MT01 AV)

Explanation: O1 audio and O1 video output ports are muted.

Legend:

<layer>	Layer
A	Audio layer
V	Video layer
AV (or nothing)	Audio & Video layer

ATTENTION! Muting does not change the crosspoint's state but disables the output itself. This way the last connection can be easily restored with an unmute command. Switching a muted output does not unmute the output.

6.3.2. Unmute Output

Description: Unmute output <out>. *#unmute_lw2*

Format	Example
Command {+<out>·<layer>} Response (0MT<out²>·<layer>)CrLf	→ {+2 A} ← (0MT02 A)

Explanation: O2 audio port is unmuted.

Legend: See in the previous section.

INFO: Unmuting an output makes the previous connection active as the crosspoint state has not been changed by the muting command, only the output was disabled.

6.3.3. Lock Output

Description: Lock an output port. Output's state cannot be changed until unlocking. *#lock_lw2*

Format	Example
Command {#><out>·<layer>} Response (1LO<out²>·<layer>)CrLf	→ {#>1 AV} ← (1LO01 AV)

Explanation: O1 audio port and O1 video output ports are locked.

Legend: See in the [Mute Output](#) section above.

6.3.4. Unlock Output

Description: Unlock an output port. The connection on output can be changed. *#unlock_lw2*

Format	Example
Command {+<out>·<layer>} Response (OLO<out²>·<layer>)CrLf	→ {+<1 A} ← (OLO01 A)

Explanation: O1 audio output port is unlocked.

Legend: See in the [Mute Output](#) section.

INFO: The device issues the above response regardless of the previous state of the output (either it was locked or unlocked).

6.3.5. View Connection State on The Output

Description: Viewing the crosspoint state of the device; showing the input port numbers connected to the outputs.

Format	Example
Command {VC·<layer>} Response (ALL<layer>·<O01>·<O02>)CrLf	→ {vc av} ← (ALLV 01 01) ← (ALLA 01 01)

Legend: All <Ox> indexes show the corresponding output's connection state. If value <O2> equals 01 it means that output 2 is connected to input 1. All <Ox> indexes are two digit ASCII characters (01 or 02).

State Letters:

Letter	State	Example
L	Output is locked	L01
M	Output is muted	M01
U	Output is locked and muted	U01

Explanation: O1 audio and O1 video output ports are connected to I1 audio and I1 video input ports.

6.3.6. View Crosspoint Size

Description: Shows the physical crosspoint size.

Format	Example
Command {GETSIZE·<layer>} Response (SIZE=<size>·<layer>)CrLf	→ {getsize av} ← (SIZE=1x1 V) ← (SIZE=1x2 A)

Legend: <size>: <number of inputs>x<number of outputs>
<layer>: See the details in the [Mute Output](#) section.

Explanation: The device reports that it has a video crosspoint with 1 input and 1 output, and an audio crosspoint with 1 input and 2 outputs.

6.4. Network Configuration

6.4.1. Query the Current IP Status

Description: IP address settings can be queried as follows.

Format	Example
Command {IP_STAT=?} Response (IP_STAT=<type>; <ip_address>;<subnet_mask>; <gateway_addr>)CrLf	→ {ip_stat=?} ← (IP_STAT=0;192.168.0.100; 255.255.255.0;192.168.0.1)

Legend:

- <type>: 0 = static IP; 1 = DHCP.
- <ip_addr>: IP address (four decimal octets separated by dots).
- <subnet_mask>: Subnet mask (four decimal octets separated by dots).
- <gateway_addr>: Gateway address (four decimal octets separated by dots).

Explanation: The device has a static (fix) IP address: 192.168.0.95; the subnet mask is 255.255.255.0, the gateway address is 192.168.0.1.

6.4.2. Set the IP Address

Description: IP address can be set as follows.

Format	Example
Command {IP_ADDRESS=<type>;<ip_address>} Response (IP_ADDRESS=<type>;<ip_address>)CrLf	→ {ip_address=0;192.168.0.110} ← (IP_ADDRESS=0;192.168.0.110;)

Legend: <type>: 0 = static IP; 1 = DHCP

INFO: The IP address can be queried by typing the "ip_address=?" command. The response contains the fix IP address that is stored in the device even if DHCP is enabled; in this case, this IP address is not valid.

6.4.3. Set the Subnet Mask

Description: Subnet mask can be set as follows.

Format	Example
Command {IP_NETMASK=<subnet_mask>} Response (IP_NETMASK=<subnet_mask>)CrLf	→ {ip_netmask=255.255.255.0} ← (IP_NETMASK=255.255.255.0)

Legend: <subnet_mask>: Four decimal octets separated by dots.

INFO: The subnet mask can be queried by typing the "ip_address=?" command. The response contains the fix IP subnet mask that is stored in the device even if DHCP is enabled; in this case, this IP subnet mask is not valid.

6.4.4. Set the Gateway Address

Description: Gateway address can be set as follows.

Format	Example
Command {IP_GATEWAY=<gateway_addr>} Response (IP_GATEWAY=<gateway_addr>)CrLf	→ {ip_gateway=192.168.0.50} ← (IP_GATEWAY=192.168.0.50)

Legend: <gateway_addr>: Four decimal octets separated by dots.

INFO: The gateway address can be queried by typing the "ip_gateway=?" command. The response contains the static IP gateway address that is stored in the device even if DHCP is enabled. In that case, the latest valid gateway address (for static IP) is stored.

6.4.5. Apply Network Settings

Description: Apply the network settings and restart the network interface.

Format	Example
Command {ip_apply} Response (IP_APPLY)CrLf	→ {ip_apply} ← (IP_APPLY)

#network_lw2 #ipaddress_lw2

6.5. RS-232 settings

6.5.1. Set RS-232 Mode

Description: RS-232 mode can be set as follows. See more details about RS-232 modes in the [Serial Interface](#) section.

Format	Example
Command {RS232=<mode>} Response (RS232=<mode>)CrLf	→ {RS232=CONTROL} ← (RS232=CONTROL)

Legend: <mode>: CONTROL = Control mode;
CI = Command Injection mode;
PASS = Pass-through.

6.5.2. Set Local RS-232 Parameters

Description: The parameters of local RS-232 port can be set as follows.

Format	Example
Command {RS232_LOCAL_FORMAT= <BaudRate>;<DataBit>; <Parity>;<StopBit>} Response (RS232_LOCAL_FORMAT= <BaudRate>;<DataBit>; <Parity>;<StopBit>)CrLf	→ {RS232_LOCAL_FORMAT=9600;9;0;X} ← (RS232_LOCAL_FORMAT=9600;9;0;1)

Legend:

<Parameter>	Parameter	Values
<BaudRate>	Baud rate	X (no change); 4800; 7200, 9600; 14400; 19200; 38400; 57600; 115200
<DataBit>	Data bit	X (no change); 8; 9
<Parity>	Parity	X (no change); N (None); E (Even); O (Odd)
<StopBit>	Stop bit	X (no change); 1; 1,5; 2

Explanation: Local RS-232 port is set the baud rate to 9600, data bit to 9, parity to odd, and stop bit is not changed, remained 1.

INFO: The current settings can be queried by the “RS232_LOCAL_FORMAT=?” command.

6.5.3. Set Link RS-232 Parameters

Description: The parameters of RS-232 TPS link port can be set as follows.

Format	Example
Command {RS232_LINK_FORMAT=<BaudRate>; <DataBit>;<Parity>;<StopBit>} Response (RS232_LINK_FORMAT=<BaudRate>; <DataBit>;<Parity>;<StopBit>)CrLf	→ {RS232_LINK_FORMAT=9600;9;0;X} ← (RS232_LINK_FORMAT=9600;9;0;1)

Legend: see previous section.

Explanation: RS-232 TPS link port is set the baud rate to 9600, data bit to 9, parity to odd, and stop bit is not changed, remained 1.

INFO: The current settings can be queried by the “RS232_LINK_FORMAT=?” command.

6.5.4. Set Local RS-232 Control Protocol Port

Description: The control protocol of local RS-232 port can be set as follows.

Format	Example
Command {RS232_LOCAL_PROT=<protocol>} Response (RS232_LOCAL_PROT=<protocol>)CrLf	→ {RS232_LOCAL_PROT=LW2} ← (RS232_LOCAL_PROT=LW2)

Legend: LW2 = LW2 command protocol LW3 = LW3 command protocol

INFO: The current setting can be queried by the “RS232_LOCAL_PROT=?” command.

6.5.5. Set Link RS-232 Control Protocol Port

Description: The port number of RS-232 TPS link port can be set as follows.

Format	Example
Command {RS232_LINK_PROT=<protocol>} Response (RS232_LINK_PROT=<protocol>)CrLf	→ {RS232_LINK_PROT=LW2} ← (RS232_LINK_PROT=LW2)

Legend: LW2 = LW2 command protocol LW3 = LW3 command protocol

INFO: The current setting can be queried by the “RS232_LINK_PROT=?” command.

#serial_lw2 #rs232_lw2 #rs-232_lw2

6.6. Relay Settings

6.6.1. Query Relay Connection State

Description: Current relay connection state can be queried. *#relay_lw2*

Format	Example
Command {RELAY<port_nr>=?}	→ {RELAY1=?}
Response (RELAY<port_nr>=<dir>;<state>)CrLf	← (RELAY1=0;0)

Legend: <dir>: it is always 0.

<state>:

Parameter	Description
C	Closed
O	Opened

Explanation: Relay1 is opened now.

6.6.2. Set Relay Connection State

Description: Relay connection state can be changed to be opened or closed.

Format	Example
Command {RELAY<port_nr>=<dir>;<state>}	→ {RELAY1=0;C}
Response (RELAY<port_nr>=<dir>;<state>)CrLf	← (RELAY1=0;C)

Legend: <dir>: it is always 0.

<state>:

Parameter	Description
C	Closed
O	Opened

Explanation: Relay1 is closed now.

6.7. LW2 Commands – Quick Summary

General LW2 Commands

Operation	See in chapter	Command
View Product Type	6.2.1	{I}
Query Control Protocol	6.2.2	{P_?}
View Firmware Version of the CPU	6.2.3	{F}
Connection Test	6.2.4	{PING}
View Serial Number	6.2.5	{S}
Compile Time	6.2.6	{CT}
View Installed Board	6.2.7	{IS}
View Firmware for All Controllers	6.2.8	{FC}
Restart the Device	6.2.9	{RST}
Query Health Status	6.2.10	{ST}
Restore Factory Default Settings	6.2.11	{FACTORY=ALL}

Port and Crosspoint Settings

Operation	See in chapter	Command
Mute Output	6.3.1	{#<out>·<layer>}
Unmute Output	6.3.2	{+<out>·<layer>}
Lock Output	6.3.3	{#><out>·<layer>}
Unlock Output	6.3.4	{+<out>·<layer>}
View Connection State on The Output	6.3.5	{VC·<layer>}
View Crosspoint Size	6.3.6	{GETSIZE·<layer>}

Network Configuration

Operation	See in chapter	Command
Query the Current IP Status	6.4.1	{IP_STAT=?}
Set the IP Address	6.4.2	{IP_ADDRESS=<type>;IP_ADDRESS}
Set the Subnet Mask	6.4.3	{IP_NETMASK=<subnet_mask>}
Set the Gateway Address	6.4.4	{IP_GATEWAY=<gateway_address>}
Apply Network Settings	6.4.5	{IP_APPLY}

RS-232 Settings

Operation	See in chapter	Command
Set RS-232 Mode	6.5.1	{RS232=<mode>}
Set Local RS-232 Parameters	6.5.2	{RS232_LOCAL_FORMAT=<BaudRate>;<DataBit>;<Parity>;<StopBit>}
Set Link RS-232 Parameters	6.5.3	{RS232_LINK_FORMAT=<BaudRate>;<DataBit>;<Parity>;<StopBit>}
Set Local RS-232 Control Protocol Port	6.5.4	RS232_LOCAL_PROT=<protocol>
Set Link RS-232 Control Protocol Port	6.5.5	RS232_LINK_PROT=<protocol>

Relay Settings

Operation	See in chapter	Command
Query Relay Connection State	6.6.1	{RELAY<port_nr>=?}
Set Relay Connection State	6.6.2	{RELAY<port_nr>=0;OIC}

7

LW3 Programmers' Reference

The device can be controlled through Lightware 3 (LW3) protocol commands to ensure the compatibility with other Lightware products. The supported LW3 commands are described in this chapter

- ▶ [OVERVIEW](#)
- ▶ [PROTOCOL RULES](#)
- ▶ [SYSTEM COMMANDS](#)
- ▶ [VIDEO PORT SETTINGS](#)
- ▶ [AUDIO PORT SETTINGS](#)
- ▶ [ANALOG AUDIO OUTPUT SETTINGS](#)
- ▶ [NETWORK CONFIGURATION](#)
- ▶ [RS-232 PORT CONFIGURATION](#)
- ▶ [RS-232 RECOGNIZER](#)
- ▶ [INFRARED PORT CONFIGURATION](#)
- ▶ [SENDING MESSAGE VIA THE COMMUNICATION PORTS](#)
- ▶ [SENDING CEC COMMANDS](#)
- ▶ [RELAY PORT SETTINGS](#)
- ▶ [EDID MANAGEMENT](#)
- ▶ [LW3 COMMANDS - QUICK SUMMARY](#)

7.1. Overview

The Lightware Protocol #3 (LW3) is implemented in almost all new Lightware devices (matrix switchers, signal extenders and distribution amplifiers) since 2012. The protocol is ASCII-based and all commands are terminated with a carriage return (Cr, '\r') and line feed (Lf, '\n') pair. It is organized as a tree structure that provides outstanding flexibility and user-friendly handling with 'nodes', 'properties' and 'methods'. The **Advanced View** of the Lightware Device Controller software is the perfect tool for browsing and learning how the LW3 protocol can be used in practice.

7.2. Protocol Rules

7.2.1. LW3 Tree Structure and Command Structure (examples)

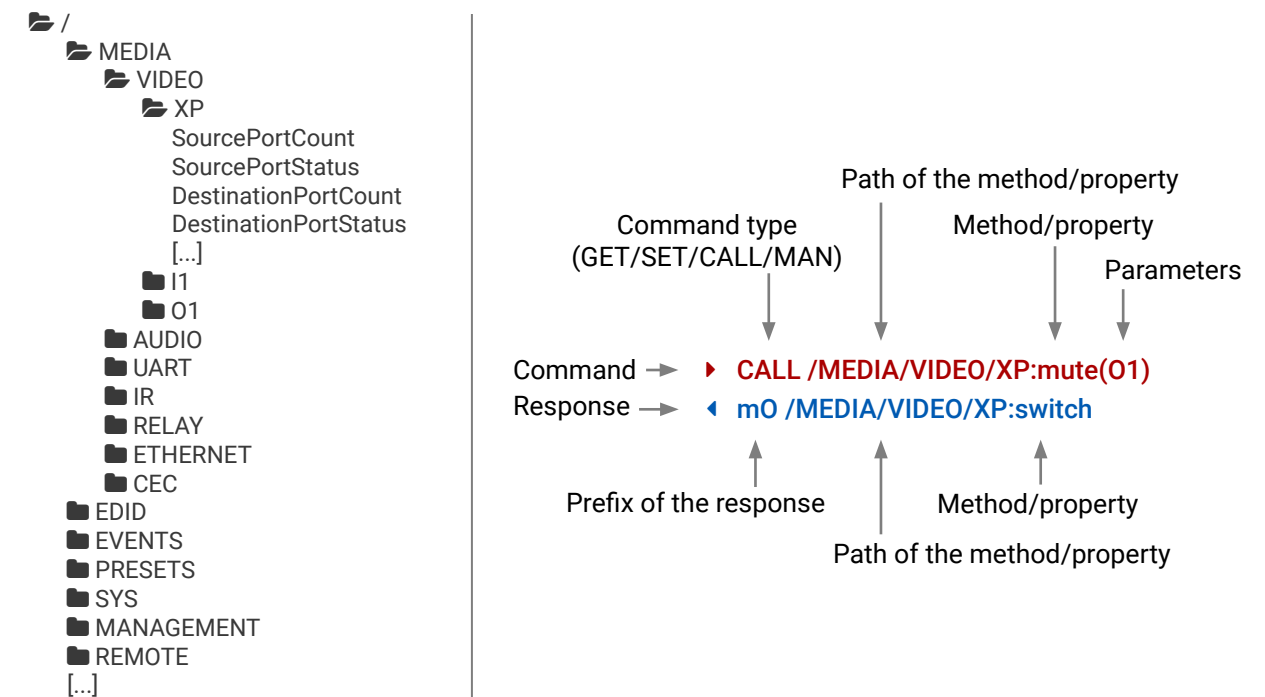

7.2.2. General Rules

- All names and parameters are **case-sensitive**.
- The nodes are separated by a slash ('/') character.
- The node name can contain the elements of the English alphabet and numbers.
- Use the **TCP port no. 6107** when using LW3 protocol over Ethernet.
- When a command is issued by the device, the received response cannot be processed by the CPU.
- The node paths describe the exact location of the node, listing each parent node up to the root.

7.2.3. Command Types

GET command

The **GET** command can be used to get the child nodes, properties and methods of a specific node. It can also be used to get the value of a property. Use the dot character (.) when addressing a property:

- ▶ **GET /.SerialNumber**
- ◀ **pr /.SerialNumber=87654321**

GETALL command

The **GETALL** command can be used to get all child nodes, properties and methods of a node with one command.

- ▶ **GETALL /MEDIA/UART**
- ◀ **ns /MEDIA/UART/RECOGNIZER**
- ◀ **ns /MEDIA/UART/P1**
- ◀ **ns /MEDIA/UART/P2**
- ◀ **pr /MEDIA/UART.PortCount=2**
- ◀ **pr /MEDIA/UART.PortUi=P1:12209;P2:12224**
- ◀ **pr /MEDIA/UART.P1=Local RS-232**
- ◀ **pr /MEDIA/UART.P2=TPS in RS-232**

SET command

The **SET** command can be used to modify the value of a property. Use the dot character (.) when addressing the property:

- ▶ **SET /MEDIA/VIDEO/O1.TpgPattern=CYCLE**
- ◀ **pw /MEDIA/VIDEO/O1.TpgPattern=CYCLE**

CALL command

A method can be invoked by the **CALL** command. Use the colon character (:) when addressing the method:

- ▶ **CALL /MEDIA/RELAY/P1.toggle(P1)**
- ◀ **mO /MEDIA/RELAY/P1.toggle**

MAN command

The manual is a human readable text that describes the syntax and provides a hint for how to use the primitives. For every node, property and method in the tree there is a manual, type the MAN command to get the manual:

- ▶ **MAN /MEDIA/VIDEO/O1.Pwr5vMode**
- ◀ **pm /MEDIA/VIDEO/O1.Pwr5vMode ["0" | "1" | "2"] 0 - Auto, 1 - Always On, 2 - Always Off**

7.2.4. Prefix Summary

DEFINITION: The prefix is a 2-character long code that describes the type of the response.

The following prefixes are defined in the LW3 protocol:

Prefix	Description	Prefix	Description
n-	a node	pm	a manual for the property
nE	an error for a node	m-	a method
nm	a manual for a node	mO	a response after a success method execution
pr	a read-only property	mF	a response after a failed method execution
pw	read-write property	mE	an error for a method
pE	an error for the property	mm	a manual for a method

7.2.5. Error Messages

There are several error messages defined in the LW3 protocol, all of them have a unique error number.

- ▶ **CALL /MEDIA/VIDEO/XP:lock(IA)**
- ◀ **mE /MEDIA/VIDEO/XP:lock %E002:Not exist**

7.2.6. Escaping

DEFINITION: An escape sequence is a sequence of characters that does not represent itself when used inside a character or string literal, but is translated into another character or a sequence of characters.

Property values and method parameters can contain characters which are used as control characters in the protocol. They must be escaped. The escape character is the backslash ('\') and escaping means injecting a backslash before the character that should be escaped (like in C language).

Control characters are the following: \ { } # % () \r \n \t

The **original** message: **CALL /MEDIA/UART/P1.sendMessage(Set(01))**

The **escaped** message: **CALL /MEDIA/UART/P1.sendMessage(Set\ (01\))**

7.2.7. Signature

DEFINITION: The signature is a four-digit-long hexadecimal value that can be optionally placed before every command to keep a command and the corresponding responses together as a group.

Each line is terminated with a carriage return (Cr, '\r') and line feed (Lf, '\n') characters. In several cases the number of the lines in the response cannot be determined in advance, e.g. the client intends to receive for the whole response and also wants to be sure, that the received lines belong together and to the same command. In these cases, a special feature the 'signature' can be used. The response to that particular command will also be preceded by the signature, and the corresponding lines will be between brackets:

```
▶ 1700#GET /EDID.*
◀ {1700
◀ pr /EDID.EdidStatus=D1:E1
◀ m- /EDID:copy
◀ m- /EDID:delete
◀ m- /EDID:reset
◀ m- /EDID:switch
◀ m- /EDID:switchAll
◀ }
```

INFO: The lines of the signature are also Cr and Lf terminated.

7.2.8. Subscription

DEFINITION: Subscription to a node means that the user will get a notification if a property of the node changes.

A user can subscribe to any node. These notifications are asynchronous messages and are useful to keep the client application up to date, without having to periodically poll the node to detect a changed property. When the user does not want to be informed about the changes anymore, he can simply unsubscribe from the node.

ATTENTION! The subscriptions are handled separately for connections. Hence, if the connection is terminated all registered subscriptions are deleted. After reopening a connection all subscribe commands have to be sent in order to get the notifications of the changes on that connection.

Subscribe to a Node

```
▶ OPEN /MEDIA/VIDEO
◀ o- /MEDIA/VIDEO
```

Get the Active Subscriptions

```
▶ OPEN
◀ o- /MEDIA/VIDEO
◀ o- /EDID
◀ o- /DISCOVERY
```

Subscribe to Multiple Nodes

```
▶ OPEN /MEDIA/VIDEO/*
◀ o- /MEDIA/VIDEO/*
```

Unsubscribe from a Node

```
▶ CLOSE /MEDIA/VIDEO
◀ c- /MEDIA/VIDEO
```

Unsubscribe from Multiple Nodes

```
▶ CLOSE /MEDIA/VIDEO/*
◀ c- /MEDIA/VIDEO/*
```

7.2.9. Notifications about the Changes of the Properties

When the value of a property is changed and the user is subscribed to the node, which the property belongs to, an asynchronous notification is generated. This notification is called as the 'change message'. The format of such a message is very similar to the response for the **GET** command:

```
◀ CHG /EDID.EdidStatus=F48:E1
```

A Short Example of How to Use the Subscription

There are two independent users controlling the device through two independent connections (**Connection #1** and **Connection #2**). The events in the rows occur after each other.

```
▶ OPEN /MEDIA/AUDIO/O2
◀ o- /MEDIA/AUDIO/O2
▶ GET /MEDIA/AUDIO/O2.VolumePercent
◀ pw /MEDIA/AUDIO/O2.VolumePercent=100.00
▶ GET /MEDIA/AUDIO/O2.VolumePercent
◀ pw /MEDIA/AUDIO/O2.VolumePercent=100.00
▶ SET /MEDIA/AUDIO/O2.VolumePercent=50.00
◀ pw /MEDIA/AUDIO/O2.VolumePercent=50.00
◀ CHG /MEDIA/AUDIO/O2.VolumePercent=50.00
```

} Connection #1
} Connection #2
→ Connection #1

Explanation: The first user (**Connection #1**) set a subscription to a node. Later the other user (**Connection #2**) made a change, and thanks for the subscription, the first user got a notification about the change.

7.2.10. Legend for the Control Commands

Format	Description
<in>	Input port number
<out>	Output port number
<port>	Input or output port number
<loc>	Location number
<parameter>	Variable, which is defined and described in the command
<expression>	Batched parameters: the underline means that more expressions or parameters can be placed by using a semicolon, e.g. O1;O2 or F27:U1;F47:U2
▶	Sent command
◀	Received response
.	Space character

7.3. System Commands

7.3.1. Query the Product Name

The name of the product is a read-only parameter and cannot be modified.

Command and Response

- ▶ GET /.ProductName
- ◀ pr /.ProductName=<Product_name>

Example

- ▶ GET /.ProductName
- ◀ pr /.ProductName=HDMI-TPS-RX110AY-Plus

7.3.2. Set the Device Label

ATTENTION! The device label can be changed to a custom text in the [Status](#) tab of the LDC software. This writable parameter is not the same as the ProductName parameter.

Command and Response #devicelabel_lw3 #label_lw3

- ▶ SET /MANAGEMENT/UID/DeviceLabel=<Custom_name>
- ◀ pw /MANAGEMENT/UID/DeviceLabel=<Custom_name>

The Device Label can be 39 character length and ASCII characters are allowed. Longer names are truncated.

Example

- ▶ SET /MANAGEMENT/UID.DeviceLabel=RX110_Conference1
- ◀ pw /MANAGEMENT/UID.DeviceLabel=RX110_Conference1

7.3.3. Query the Serial Number

Command and Response

- ▶ GET /.SerialNumber
- ◀ pr /.SerialNumber=<serial_nr>

Example

- ▶ GET /.SerialNumber
- ◀ pr /.SerialNumber=87654321

7.3.4. Query the Firmware Version

Command and Response #firmwareversion_lw3

- ▶ GET /SYS/MB.FirmwareVersion
- ◀ pr /SYS/MB.FirmwareVersion=<firmware_version>

Example

- ▶ GET /SYS/MB.FirmwareVersion
- ◀ pr /SYS/MB.FirmwareVersion=1.3.1b6

7.3.5. Identify the Device

Calling the method results the blinking of the status LEDs for 10 seconds. The feature helps to identify the device itself in the rack shelf.

Command and Response #identifyme_lw3

- ▶ CALL /MANAGEMENT/UI:identifyMe()
- ◀ mO /MANAGEMENT/UI:identifyMe=

Example

- ▶ CALL /MANAGEMENT/UI:identifyMe()
- ◀ mO /MANAGEMENT/UI:identifyMe

7.3.6. Dark Mode

This command turns LEDs off the on the transmitter.

Command and Response #darkmode_lw3 #new

- ▶ SET /MANAGEMENT/UI/DARKMODE.DarkModeEnable=<status>
- ◀ pw /MANAGEMENT/UI/DARKMODE.DarkModeEnable=<status>

Parameters

Identifier	Parameter description	Value	Explanation
<status>	Status of the dark mode	true	Dark mode is enabled.
		false	Dark mode is disabled.

Example

- ▶ SET /MANAGEMENT/UI/DARKMODE.DarkModeEnable=true
- ◀ pw /MANAGEMENT/UI/DARKMODE.DarkModeEnable=true

7.3.7. Restarting the Device

The receiver can be restarted – the current connections (LAN, RS-232, USB) will be terminated.

Command and Response *#restart_lw3 #reboot_lw3*

- ▶ CALL:/SYS:reset()
- ◀ mO:/SYS:reset=

Example

- ▶ **CALL /SYS:reset()**
- ◀ **mO /SYS:reset=**

7.3.8. Restore the Factory Default Settings

Command and Response *#factory_lw3*

- ▶ CALL:/SYS:factoryDefaults()
- ◀ mO:/SYS:factoryDefaults=

Example

- ▶ **CALL /SYS:factoryDefaults()**
- ◀ **mO /SYS:factoryDefaults=**

The device is restarted, current connections are terminated, and the default settings are restored. See the complete list in the [Factory Default Settings](#) section.

7.4. Video Port Settings

INFO: Video port numbering can be found in the [Input/Output Port Numbering](#) section.

7.4.1. Query the Status of Source Ports

Command and Response *#portstatus_lw3*

- ▶ GET:/MEDIA/VIDEO/XP.SourcePortStatus
- ◀ pr:/MEDIA/VIDEO/XP.SourcePortStatus=<in_state>

The response contains 5 ASCII characters for each port. The first character indicates the mute/lock state, the next four characters represent a 2-byte HEX code showing the current state of the input ports.

Example

- ▶ **GET /MEDIA/VIDEO/XP.SourcePortStatus**
- ◀ **pr /MEDIA/VIDEO/XP.SourcePortStatus=M00AA**

Parameters

	Letter (Character 1)	
	Mute state	Lock state
T	Unmuted	Unlocked
L	Unmuted	Locked
M	Muted	Unlocked
U	Muted	Locked

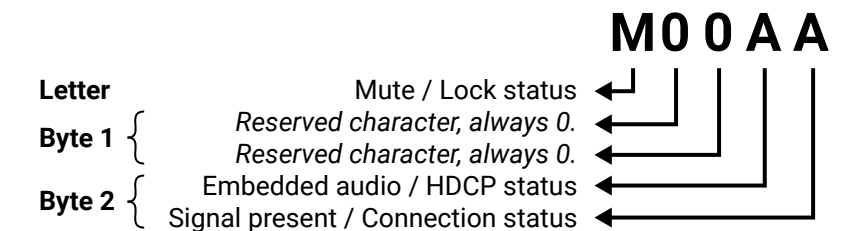

	Byte 1				Byte 2			
	Character 2		Character 3		Character 4		Character 5	
	BIT 7-6	BIT 5-4	BIT 3-2	BIT 1-0	BIT 7-6	BIT 5-4	BIT 3-2	BIT 1-0
	Reserved	Reserved	Reserved	Reserved	Embedded audio status	HDCP status	Signal present status	Connection status
00	Unknown							
01	Reserved							
10	Reserved	Reserved	Reserved	Reserved	No embedded audio	Not encrypted	No signal	Not connected
11					Embedded audio presents	Encrypted	Signal presents	Connected

The Most Common Received Port Status Responses

T00AA	T	0		0		A		A	
	Unlocked, Unmuted	00	00	00	00	10	10	10	10
		Reserved	Reserved	Reserved	Reserved	No embedded audio	Not encrypted	No signal	Not connected
T00AB	T	0		0		A		B	
	Unlocked, Unmuted	00	00	00	00	10	10	10	11
		Reserved	Reserved	Reserved	Reserved	No embedded audio	Not encrypted	No signal	Connected
T00AF	T	0		0		A		F	
	Unlocked, Unmuted	00	00	00	00	10	10	11	11
		Reserved	Reserved	Reserved	Reserved	No embedded audio	Not encrypted	Signal presents	Connected
T00EF	T	0		0		E		F	
	Unlocked, Unmuted	00	00	00	00	11	10	11	11
		Reserved	Reserved	Reserved	Reserved	Embedded audio presents	Not encrypted	Signal presents	Connected
T00BF	T	0		0		B		F	
	Unlocked, Unmuted	00	00	00	00	10	11	11	11
		Reserved	Reserved	Reserved	Reserved	No embedded audio	Encrypted	Signal presents	Connected
T00FF	T	0		0		F		F	
	Unlocked, Unmuted	00	00	00	00	11	11	11	11
		Reserved	Reserved	Reserved	Reserved	Embedded audio presents	Encrypted	Signal presents	Connected

7.4.2. Query the Status of Destination Port

Command and Response *#portstatus_lw3*

- ▶ GET·/MEDIA/VIDEO/XP.DestinationPortStatus
- ◀ pr·/MEDIA/VIDEO/XP.DestinationPortStatus=<out_state>

Parameters

<out_state>: the response contains 5 ASCII characters for each port. The first character indicates the mute/lock state, the next 2-byte long HEX code showing the current state of the output port.

Example

- ▶ GET /MEDIA/VIDEO/XP.DestinationPortStatus
- ◀ pr /MEDIA/VIDEO/XP.DestinationPortStatus=M00BF

Legend

See at previous section.

Explanation

M	0		0		B		F	
Unlocked,	00	00	00	00	10	11	11	11
Muted	Reserved	Reserved	Reserved	Reserved	No embedded audio	Encrypted	Signal presents	Connected

7.4.3. Mute Input

Command and Response *#mute_lw3*

- ▶ CALL·/MEDIA/VIDEO/XP:muteSource(<in>)
- ◀ m0·/MEDIA/VIDEO/XP:muteSource

Example

- ▶ CALL /MEDIA/VIDEO/XP:muteSource(I1)
- ◀ m0 /MEDIA/VIDEO/XP:muteSource

7.4.4. Unmute Input

Command and Response *#unmute_lw3*

- ▶ CALL·/MEDIA/VIDEO/XP:unmuteSource(<in>)
- ◀ m0·/MEDIA/VIDEO/XP:unmuteSource

Example

- ▶ CALL /MEDIA/VIDEO/XP:unmuteSource(I1)
- ◀ m0 /MEDIA/VIDEO/XP:unmuteSource

7.4.5. Lock Input

Command and Response *#lock_lw3*

- ▶ CALL·/MEDIA/VIDEO/XP:lockSource(<in>)
- ◀ mO·/MEDIA/VIDEO/XP:lockSource

Example

- ▶ CALL /MEDIA/VIDEO/XP:lockSource(I1)
- ◀ mO /MEDIA/VIDEO/XP:lockSource

7.4.6. Unlock Input

Command and Response *#unlock_lw3*

- ▶ CALL·/MEDIA/VIDEO/XP:unlockSource(<in>)
- ◀ mO·/MEDIA/VIDEO/XP:unlockSource

Example

- ▶ CALL /MEDIA/VIDEO/XP:unlockSource(I1)
- ◀ mO /MEDIA/VIDEO/XP:unlockSource

7.4.7. Mute Output

Command and Response *#mute_lw3*

- ▶ CALL·/MEDIA/VIDEO/XP:muteDestination(<out>)
- ◀ mO·/MEDIA/VIDEO/XP:muteDestination

Example

- ▶ CALL /MEDIA/VIDEO/XP:muteDestination(O1)
- ◀ mO /MEDIA/VIDEO/XP:muteDestination

7.4.8. Unmute Output

Command and Response *#unmute_lw3*

- ▶ CALL·/MEDIA/VIDEO/XP:unmuteDestination(<out>)
- ◀ mO·/MEDIA/VIDEO/XP:unmuteDestination

Example

- ▶ CALL /MEDIA/VIDEO/XP:unmuteDestination(O1)
- ◀ mO /MEDIA/VIDEO/XP:unmuteDestination

7.4.9. Lock Output

Command and Response *#lock_lw3*

- ▶ CALL·/MEDIA/VIDEO/XP:lockDestination(<out>)
- ◀ mO·/MEDIA/VIDEO/XP:lockDestination

Example

- ▶ CALL /MEDIA/VIDEO/XP:lockDestination(O1)
- ◀ mO /MEDIA/VIDEO/XP:lockDestination

7.4.10. Unlock Output

Command and Response *#unlock_lw3*

- ▶ CALL·/MEDIA/VIDEO/XP:unlockDestination(<out>)
- ◀ mO·/MEDIA/VIDEO/XP:unlockDestination

Example

- ▶ CALL /MEDIA/VIDEO/XP:unlockDestination(O1)
- ◀ mO /MEDIA/VIDEO/XP:unlockDestination

7.4.11. HDCP Setting (Input Port)

HDCP capability can be enabled/disabled on the input ports, thus, non-encrypted content can be seen on a non-HDCP compliant display. See more information in the [HDCP Management](#) section.

Command and Response *#hdcplw3*

- ▶ SET·/MEDIA/VIDEO/<in>.HdcpEnable=<logical_value>
- ◀ pw·/MEDIA/VIDEO/<in>.HdcpEnable=<logical_value>

Parameters

Identifier	Parameter description	Value	Parameter value
<logical_value>	HDCP enable/disable setting	true	HDCP encryption is enabled.
		false	HDCP encryption is disabled.

Example

- ▶ SET /MEDIA/VIDEO/I1.HdcpEnable=false
- ◀ pw /MEDIA/VIDEO/I1.HdcpEnable=false

7.4.12. HDCP Setting (Output Port)

HDCP capability can be set to Auto/Always on the output ports, thus, non-encrypted content can be transmitted to a non-HDCP compliant display. See more information in the [HDCP Management](#) section.

Command and Response #hdcplw3

- ▶ SET /MEDIA/VIDEO/<out>.HdcpModeSetting=<HDCP_mode>
- ◀ pw /MEDIA/VIDEO/<out>.HdcpModeSetting=<HDCP_mode>

Parameters

Identifier	Parameter description	Value	Parameter value
<HDCP_mode>	HDCP mode	0	Auto
		1	Always

Example

- ▶ SET /MEDIA/VIDEO/O1.HdcpModeSetting=0
- ◀ pw /MEDIA/VIDEO/O1.HdcpModeSetting=0

7.4.13. Test Pattern Generator Mode

The output port can send a special image towards the sink device for testing purposes. The setting is available on the input ports with the below-listed parameters.

Command and Response #testpattern_lw3

- ▶ SET /MEDIA/VIDEO/<out>.TpgMode=<mode>
- ◀ pw /MEDIA/VIDEO/<out>.TpgMode=<mode>

Parameters

Identifier	Parameter description	Value	Parameter value
<mode>	Test pattern generator mode	0	Always off: the test pattern is not displayed on the output.
		1	Always on: the test pattern is displayed on the output.
		2	Auto: the test pattern is displayed if there is no signal on the input port.

Example

- ▶ SET /MEDIA/VIDEO/O1.TpgMode=2
- ◀ pw /MEDIA/VIDEO/O1.TpgMode=2

7.4.14. Test Pattern Generator Clock Source

Command and Response

- ▶ SET /MEDIA/VIDEO/<out>.TpgClockSource=<clock_frequency>
- ◀ pw /MEDIA/VIDEO/<out>.TpgClockSource=<clock_frequency>

Parameters

Identifier	Parameter description	Value	Parameter value
<clock_frequency>	Clock frequency	480	480p
		576	576p
		EXT	External clock (from actual TMDS source)

Example

- ▶ SET /MEDIA/VIDEO/O1.TpgClockSource=576
- ◀ pw /MEDIA/VIDEO/O1.TpgClockSource=576

7.4.15. Test Pattern Setting

Command and Response

- ▶ SET /MEDIA/VIDEO/<out>.TpgPattern=<pattern>
- ◀ pw /MEDIA/VIDEO/<out>.TpgPattern=<pattern>

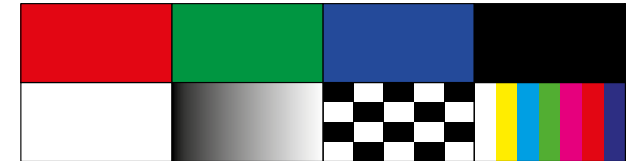

Parameters

Identifier	Parameter description	Value	Parameter value
<pattern>	The test pattern displayed on the sink device	RED	Red
		GREEN	Green
		BLUE	Blue
		BLACK	Black
		WHITE	White
		RAMP	Ramp
		CHESS	Chess
		BAR	Bar
		CYCLE	Cycle setting means all the patterns are changed sequentially approx. in every 2 seconds

Example

- ▶ SET /MEDIA/VIDEO/O1.TpgPattern=GREEN
- ◀ pw /MEDIA/VIDEO/O1.TpgPattern=GREEN

7.4.16. HDMI Mode Settings (Output Port)

Command and Response *#hdmimode_lw3*

- ▶ SET·/MEDIA/VIDEO/<out>.HdmiModeSetting=<mode>
- ◀ pw·/MEDIA/VIDEO/<out>.HdmiModeSetting=<mode>

Parameters

Identifier	Parameter description	Value	Parameter value
<mode>	HDMI mode	0	Auto
		1	DVI
		2	HDMI

Example

- ▶ SET /MEDIA/VIDEO/01.HdmiModeSetting=2
- ◀ pw /MEDIA/VIDEO/01.HdmiModeSetting=2

7.4.17. Query the Recent TPS Mode

Command and Response *#tpsmode_lw3*

- ▶ GET·/REMOTE/<port>.tpsMode
- ◀ pr·/REMOTE/<port>.tpsMode=<TPS_mode>

Parameters

Identifier	Parameter description	Value	Parameter value
<TPS_mode>	TPS mode	A	Auto
		H	HDBaseT
		L	Long reach
		1	LPPF1
		2	LPPF2

Example

- ▶ GET /REMOTE/S1.tpsMode
- ◀ pr /REMOTE/S1.tpsMode=H

See more information about TPS modes in the [TPS Interface](#) section.

7.4.18. TPS Mode Settings

Command and Response

- ▶ SET·/REMOTE/<port>.tpsModeSetting=<TPS_mode>
- ◀ pw·/REMOTE/<port>.tpsModeSetting=<TPS_mode>

Parameters

Identifier	Parameter description	Value	Parameter value
<TPS_mode>	TPS mode	A	Auto
		H	HDBaseT
		L	Long reach
		1	LPPF1
		2	LPPF2

Example

- ▶ SET /REMOTE/S1.tpsModeSetting=A
- ◀ pw /REMOTE/S1.tpsModeSetting=A

See more information about TPS modes in the [TPS Interface](#) section.

7.5. Audio Port Settings

INFO: Audio port numbering can be found in the [Input/Output Port Numbering](#) section.

7.5.1. Query the Status of Source Ports

Command and Response `#portstatus_lw3`

- ▶ `GET:/MEDIA/AUDIO/XP.SourcePortStatus`
- ◀ `pr:/MEDIA/AUDIO/XP.SourcePortStatus=<in_state>`

The response contains 5 ASCII characters for each port. The first character indicates the mute/lock state, the next four characters represent a 2-byte HEX code showing the current state of the input port.

Example

- ▶ `GET /MEDIA/AUDIO/XP.SourcePortStatus`
- ◀ `pr /MEDIA/AUDIO/XP.SourcePortStatus=T000F`

Legend:

Letter (Character 1)		
	Mute state	Lock state
T	Unmuted	Unlocked
L	Unmuted	Locked
M	Muted	Unlocked
U	Muted	Locked

Letter

Byte 1

Byte 2

Mute / Lock status
 Reserved character, always 0.
 Reserved character, always 0.
 Reserved character, always 0.
 Signal present / Connection status

T 0 0 0 F

	Byte 1				Byte 2			
	Character 2		Character 3		Character 4		Character 5	
	BIT 7-6	BIT 5-4	BIT 3-2	BIT 1-0	BIT 7-6	BIT 5-4	BIT 3-2	BIT 1-0
	Reserved	Reserved	Reserved	Reserved	Reserved	Reserved	Signal present status	Connection status
00							Unknown	
01							Reserved	
10	Reserved	Reserved	Reserved	Reserved	Reserved	Reserved	No signal	Not connected
11							Signal presents	Connected

The Most Common Received Port Status Responses

T000A	T	0		0		0		A	
	Unlocked, Unmuted	00	00	00	00	00	00	00	10
	Reserved	Reserved	Reserved	Reserved	Reserved	Reserved	Reserved	No signal	Not connected

T000B	T	0		0		0		B	
	Unlocked, Unmuted	00	00	00	00	00	00	00	10
	Reserved	Reserved	Reserved	Reserved	Reserved	Reserved	Reserved	No signal	Connected

T000F	T	0		0		0		F	
	Unlocked, Unmuted	00	00	00	00	00	00	00	11
	Reserved	Reserved	Reserved	Reserved	Reserved	Reserved	Reserved	Signal presents	Connected

Only for Phoenix audio port: Character 5 is C (11 00) which means signal is present but the cable connection status is unknown. The explanation is Phoenix connector has no pin which can indicate the connection status so this is always unknown.

T000C	T	0		0		0		C	
	Unlocked, Unmuted	00	00	00	00	00	00	00	11
	Reserved	Reserved	Reserved	Reserved	Reserved	Reserved	Reserved	Signal presents	Unknown

7.5.2. Query the Status of Destination Port

Command and Response #portstatus_lw3

- ▶ GET·/MEDIA/AUDIO/XP.DestinationPortStatus
- ◀ pr·/MEDIA/AUDIO/XP.DestinationPortStatus=<out1_state>;<out2_state>

The response contains 5 ASCII characters for each port. The first character indicates the mute/lock state, the next 2-byte long HEX code showing the current state of the output port.

Example

- ▶ GET /MEDIA/AUDIO/XP.DestinationPortStatus
- ◀ pr /MEDIA/AUDIO/XP.DestinationPortStatus=T000F;T000B

Legend

See at previous section.

Example and Explanation

T	0		0		0		F	
Unlocked, Unmuted	00	00	00	00	00	00	11	11
	Reserved	Reserved	Reserved	Reserved	Reserved	Reserved	Signal presents	Connected

7.5.3. Mute Input

Command and Response #mute_lw3

- ▶ CALL·/MEDIA/AUDIO/XP:muteSource(<in>)
- ◀ mO·/MEDIA/AUDIO/XP:muteSource

Example

- ▶ CALL /MEDIA/AUDIO/XP:muteSource(I1)
- ◀ mO /MEDIA/AUDIO/XP:muteSource

7.5.4. Unmute Input

Command and Response #unmute_lw3

- ▶ CALL·/MEDIA/AUDIO/XP:unmuteSource(<in>)
- ◀ mO·/MEDIA/AUDIO/XP:unmuteSource

Example

- ▶ CALL /MEDIA/AUDIO/XP:unmuteSource(I1)
- ◀ mO /MEDIA/AUDIO/XP:unmuteSource

7.5.5. Lock Input

Command and Response #lock_lw3

- ▶ CALL·/MEDIA/AUDIO/XP:lockSource(<in>)
- ◀ mO·/MEDIA/AUDIO/XP:lockSource

Example

- ▶ CALL /MEDIA/AUDIO/XP:lockSource(I1)
- ◀ mO /MEDIA/AUDIO/XP:lockSource

7.5.6. Unlock Input

Command and Response #unlock_lw3

- ▶ CALL·/MEDIA/AUDIO/XP:unlockSource(<in>)
- ◀ mO·/MEDIA/AUDIO/XP:unlockSource

Example

- ▶ CALL /MEDIA/AUDIO/XP:unlockSource(I1)
- ◀ mO /MEDIA/AUDIO/XP:unlockSource

7.5.7. Mute Output

Command and Response #mute_lw3

- ▶ CALL·/MEDIA/AUDIO/XP:muteDestination(<out>)
- ◀ mO·/MEDIA/AUDIO/XP:muteDestination

Example

- ▶ CALL /MEDIA/AUDIO/XP:muteDestination(O1)
- ◀ mO /MEDIA/AUDIO/XP:muteDestination

7.5.8. Unmute Output

Command and Response #unmute_lw3

- ▶ CALL·/MEDIA/AUDIO/XP:unmuteDestination(<out>)
- ◀ mO·/MEDIA/AUDIO/XP:unmuteDestination

Example

- ▶ CALL /MEDIA/AUDIO/XP:unmuteDestination(O1)
- ◀ mO /MEDIA/AUDIO/XP:unmuteDestination

7.5.9. Lock Output

Command and Response *#lock_lw3*

- ▶ CALL·/MEDIA/AUDIO/XP:lockDestination(<out>)
- ◀ mO·/MEDIA/AUDIO/XP:lockDestination

Example

- ▶ CALL /MEDIA/AUDIO/XP:lockDestination(O1)
- ◀ mO /MEDIA/AUDIO/XP:lockDestination

7.5.10. Unlock Output

Command and Response *#unlock_lw3*

- ▶ CALL·/MEDIA/AUDIO/XP:unlockDestination(<out>)
- ◀ mO·/MEDIA/AUDIO/XP:unlockDestination

Example

- ▶ CALL /MEDIA/AUDIO/XP:unlockDestination(O1)
- ◀ mO /MEDIA/AUDIO/XP:unlockDestination

7.6. Analog Audio Output Settings

7.6.1. Volume Setting (dB)

Command and Response *#analogaudio_lw3 #volume_lw3*

- ▶ SET·/MEDIA/AUDIO/<out>.VolumedB=<level>
- ◀ pw·/MEDIA/AUDIO/<out>.VolumedB=<level>

Parameters

- <level> Sets the output volume (attenuation) between -95.625 dB and 0 dB in step of -0.375 dB. The value is rounded up if necessary to match with the step value.

Example

- ▶ SET /MEDIA/AUDIO/O2.VolumedB=-15
- ◀ pw /MEDIA/AUDIO/O2.VolumedB=-15.00

7.6.2. Volume Setting (dB) in Steps

Command and Response

- ▶ CALL·/MEDIA/AUDIO/<out>.stepVolumedB(<step>)
- ◀ mO·/MEDIA/AUDIO/<out>.stepVolumedB

Parameters

- <level> Sets the output volume (attenuation) between -95.625 dB and 0 dB in step of -0.375 dB. The value is rounded up if necessary to match with the step value.

Example

- ▶ CALL /MEDIA/AUDIO/O2.stepVolumedB(5)
- ◀ mO /MEDIA/AUDIO/O2.stepVolumedB

7.6.3. Volume Setting (Percent)

Command and Response

- ▶ SET·/MEDIA/AUDIO/<out>.VolumePercent=<percent>
- ◀ pw·/MEDIA/AUDIO/<out>.VolumePercent=<percent>

Parameters

- <level> Sets the output volume (attenuation) between 100% and 0%, in step of 1%. The value is rounded up if necessary to match with the step value.

Example

- ▶ SET /MEDIA/AUDIO/O2.VolumePercent=50
- ◀ pw /MEDIA/AUDIO/O2.VolumePercent=50

7.6.4. Volume Setting (Percent) in Steps

Command and Response

- ▶ CALL·/MEDIA/AUDIO/<out>.stepVolumePercent(<percent>)
- ◀ pw·/MEDIA/AUDIO/<out>.stepVolumePercent

Parameters

- <level> Sets the output volume (attenuation) between 100% and 0%, in step of 1%. The value is rounded up if necessary to match with the step value.

Example

- ▶ CALL /MEDIA/AUDIO/O2.stepVolumePercent(15)
- ◀ mO /MEDIA/AUDIO/O2.stepVolumePercent

7.6.5. Balance Setting

Command and Response *#balance_lw3*

- ▶ SET /MEDIA/AUDIO/<out>.Balance=<level>
- ◀ pw /MEDIA/AUDIO/<out>.Balance=<level>

Parameters

- <level> Sets the balance; -100 means left balance, 100 means right balance, step is 1. Center is 0 (default).

Example

- ▶ SET /MEDIA/AUDIO/O2.Balance=0
- ◀ pw /MEDIA/AUDIO/O2.Balance=0

7.6.6. Balance Setting in Steps

Command and Response

- ▶ CALL /MEDIA/AUDIO/<out>.stepBalance(<level>)
- ◀ mO /MEDIA/AUDIO/<out>.stepBalance

Parameters

- <level> Sets the balance; -100 means left balance, 100 means right balance, step is 1. Center is 0 (default).

Example

- ▶ CALL /MEDIA/AUDIO/O2.stepBalance(1)
- ◀ mO /MEDIA/AUDIO/O2.stepBalance

7.7. Network Configuration

7.7.1. Query the DHCP State

Command and Response *#network_lw3 #ipaddress_lw3 #dhcp_lw3*

- ▶ GET /MANAGEMENT/NETWORK.DhcpEnabled
- ◀ pw /MANAGEMENT/NETWORK.DhcpEnabled=<logical_value>

Parameters

Identifier	Parameter description	Value	Parameter value
<logical_value>	DHCP (dynamic IP address) setting	true	Dynamic IP address is set.
		false	Fix IP address is set.

Example

- ▶ GET /MANAGEMENT/NETWORK.DhcpEnabled
- ◀ pw /MANAGEMENT/NETWORK.DhcpEnabled=true

7.7.2. Change the DHCP State

Command and Response

- ▶ SET /MANAGEMENT/NETWORK.DhcpEnabled=<logical_value>
- ◀ pw /MANAGEMENT/NETWORK.DhcpEnabled=<logical_value>

Parameters

See the previous section.

Example

- ▶ SET /MANAGEMENT/NETWORK.DhcpEnabled=false
- ◀ pw /MANAGEMENT/NETWORK.DhcpEnabled=false

7.7.3. Query the IP Address

Command and Response

- ▶ GET /MANAGEMENT/NETWORK.IpAddress
- ◀ pr /MANAGEMENT/NETWORK.IpAddress=<IP_Address>

Example

- ▶ GET /MANAGEMENT/NETWORK.IpAddress
- ◀ pr /MANAGEMENT/NETWORK.IpAddress=192.168.0.100

7.7.4. Change the IP Address (Static)

Command and Response

- ▶ SET /MANAGEMENT/NETWORK.StaticIpAddress=<IP_address>
- ◀ pw /MANAGEMENT/NETWORK.StaticIpAddress=<IP_address>

Example

- ▶ SET /MANAGEMENT/NETWORK.StaticIpAddress=192.168.0.85
- ◀ pw /MANAGEMENT/NETWORK.StaticIpAddress=192.168.0.85

7.7.5. Query the Subnet Mask

Command and Response

- ▶ GET /MANAGEMENT/NETWORK.NetworkMask
- ◀ pr /MANAGEMENT/NETWORK.NetworkMask=<netmask>

Example

- ▶ GET /MANAGEMENT/NETWORK.NetworkMask
- ◀ pr /MANAGEMENT/NETWORK.NetworkMask=255.255.255.0

7.7.6. Change the Subnet Mask (Static)

Command and Response

- ▶ SET /MANAGEMENT/NETWORK.StaticNetworkMask=<netmask>
- ◀ pw /MANAGEMENT/NETWORK.StaticNetworkMask=<netmask>

Example

- ▶ SET /MANAGEMENT/NETWORK.StaticNetworkMask=255.255.255.0
- ◀ pw /MANAGEMENT/NETWORK.StaticNetworkMask=255.255.255.0

7.7.7. Query the Gateway Address

Command and Response

- ▶ GET /MANAGEMENT/NETWORK.GatewayAddress
- ◀ pr /MANAGEMENT/NETWORK.GatewayAddress=<gw_address>

Example

- ▶ GET /MANAGEMENT/NETWORK.GatewayAddress
- ◀ pr /MANAGEMENT/NETWORK.GatewayAddress=192.168.0.1

7.7.8. Change the Gateway Address (Static)

Command and Response

- ▶ SET /MANAGEMENT/NETWORK.StaticGatewayAddress=<gw_address>
- ◀ pw /MANAGEMENT/NETWORK.StaticGatewayAddress=<gw_address>

Example

- ▶ SET /MANAGEMENT/NETWORK.StaticGatewayAddress=192.168.0.5
- ◀ pw /MANAGEMENT/NETWORK.StaticGatewayAddress=192.168.0.5

7.7.9. Query the MAC Address

Command and Response

- ▶ GET /MANAGEMENT/NETWORK.MacAddress
- ◀ pr /MANAGEMENT/NETWORK.MacAddress=<MAC_address>

Example

- ▶ GET /MANAGEMENT/NETWORK.MacAddress
- ◀ pr /MANAGEMENT/NETWORK.MacAddress=A8:D2:36:00:43:12

7.7.10. Apply Network Settings

Calling the method results all network settings are applied in the device.

Command and Response

- ▶ CALL /MANAGEMENT/NETWORK.ApplySettings()
- ◀ mO /MANAGEMENT/NETWORK.ApplySettings

Example

- ▶ CALL /MANAGEMENT/NETWORK.ApplySettings()
- ◀ mO /MANAGEMENT/NETWORK.ApplySettings

7.8. RS-232 Port Configuration

INFO: Serial (local and link) port numbering can be found in the [Input/Output Port Numbering](#) section.

7.8.1. Protocol Setting

Command and Response *#rs232_lw3 #rs-232_lw3 #serial_lw3*

- ▶ SET·/MEDIA/UART/<port>.ControlProtocol=<protocol>
- ◀ pw·/MEDIA/UART/<port>.ControlProtocol=<protocol>

Parameters

Identifier	Parameter description	Value	Parameter value
<protocol>	Control protocol which is applied on the selected serial port	0	LW2 protocol
		1	LW3 protocol

Example

- ▶ SET /MEDIA/UART/P1.ControlProtocol=1
- ◀ pw /MEDIA/UART/P1.ControlProtocol=1

7.8.2. BAUD Rate Setting

Command and Response

- ▶ SET·/MEDIA/UART/<port>.Baudrate=<baudrate>
- ◀ pw·/MEDIA/UART/<port>.Baudrate=<baudrate>

Parameters

Identifier	Parameter description	Value	Parameter value
<baudrate>	BAUD rate value	0	4800
		1	7200
		2	9600
		3	14400
		4	19200
		5	38400
		6	57600
		7	115200

Example

- ▶ SET /MEDIA/UART/P1.Baudrate=2
- ◀ pw /MEDIA/UART/P1.Baudrate=2

7.8.3. Databits Setting

Command and Response

- ▶ SET·/MEDIA/UART/<port>.DataBits=<databits>
- ◀ pw·/MEDIA/UART/<port>.DataBits=<databits>

Parameters

Identifier	Parameter description	Value	Parameter value
<databits>	Databits value	8	8
		9	9

Example

- ▶ SET /MEDIA/UART/P1.DataBits=8
- ◀ pw /MEDIA/UART/P1.DataBits=8

7.8.4. Stopbits Setting

Command and Response

- ▶ SET·/MEDIA/UART/<port>.StopBits=<stopbits>
- ◀ pw·/MEDIA/UART/<port>.StopBits=<stopbits>

Parameters

Identifier	Parameter description	Value	Parameter value
<stopbits>	Stopbits value	0	1
		1	1,5
		2	2

Example

- ▶ SET /MEDIA/UART/P1.StopBits=0
- ◀ pw /MEDIA/UART/P1.StopBits=0

7.8.5. Parity Setting

Command and Response

- ▶ SET·/MEDIA/UART/ <port>.Parity=<parity>
- ◀ pw·/MEDIA/UART/<port>.Parity=<parity>

Parameters

Identifier	Parameter description	Value	Parameter value
		0	None
<parity>	Parity setting	1	Odd
		2	Even

Example

- ▶ SET /MEDIA/UART/P1.Parity=0
- ◀ pw /MEDIA/UART/P1.Parity=0

7.8.6. RS-232 Operation Mode

Command and Response

- ▶ SET·/MEDIA/UART/<port>.Rs232Mode=<mode>
- ◀ pw·/MEDIA/UART/<port>.Rs232Mode=<mode>

Parameters

Identifier	Parameter description	Value	Parameter value
		0	Pass-through
<stopbits>	Stopbits value	1	Control
		2	Command injection

Example

- ▶ SET /MEDIA/UART/P1.Rs232Mode=1
- ◀ pw /MEDIA/UART/P1.Rs232Mode=1

7.8.7. Query the Command Injection Mode

Command and Response

- ▶ GET·/MEDIA/UART/<port>.CommandInjectionStatus
- ◀ pr·/MEDIA/UART/<port>.CommandInjectionStatus=<logical_value>

Parameters

Identifier	Parameter description	Value	Parameter value
<logical_value>	Command injection mode status	true	Command injection mode is enabled.
		false	Command injection mode is disabled.

Example

- ▶ SET /MEDIA/UART/P1.CommandInjection=true
- ◀ pw /MEDIA/UART/P1.CommandInjectionEnable=true

7.8.8. Change the Command Injection Mode

Command and Response

- ▶ SET·/MEDIA/UART/<port>.CommandInjectionEnable=<logical_value>
- ◀ pw·/MEDIA/UART/<port>.CommandInjectionEnable=<logical_value>

Parameters

Identifier	Parameter description	Value	Parameter value
<logical_value>	Command injection mode setting	true	Command injection mode is enabled.
		false	Command injection mode is disabled.

Example

- ▶ SET /MEDIA/UART/P1.CommandInjectionEnable=true
- ◀ pw /MEDIA/UART/P1.CommandInjectionEnable=true

ATTENTION! The local RS-232 and TPS serial link are mirrored. If you change the RS-232 mode on P1 (local) port, the P2 (TPS serial link) will also be changed.

7.9. RS-232 Recognizer

DIFFERENCE: This feature is available only in the HDMI-TPS-RX110AY-Plus model.

This tool is able to recognize the incoming RS-232 message. It stores the incoming serial data from the first bit, until the previously defined string (delimiter) or the elapsing timeout after the last bit. The last incoming serial string is saved in different formats (string, hex, and hash).

7.9.1. Enable the Recognizer

- ▶ SET·/MEDIA/UART/<port>.RecognizerEnable=<logical_value>
- ◀ pw·/MEDIA/UART/<port>.RecognizerEnable=<logical_value>

Parameters

Identifier	Parameter description	Value	Parameter value
<logical_value>	Recognizer enable/disable setting	true false	Enabled Disabled

Example

- ▶ SET /MEDIA/UART/P1.RecognizerEnable=true
- ◀ pw /MEDIA/UART/P1.RecognizerEnable=true

7.9.2. Set the Delimiter Hex

When the delimiter hex string is detected in the incoming serial data, the device saves the RS-232 message data from the first bit, until the delimiter (or the data between the two delimiters).



- ▶ SET·/MEDIA/UART/RECOGNIZER.DelimiterHex=<delimiter>
- ◀ pw·/MEDIA/UART/RECOGNIZER.DelimiterHex=<delimiter>

Parameters

<delimiter> It can be max. 8-character long (or 16 hex digit) in hex format.

Example

- ▶ SET /MEDIA/UART/RECOGNIZER.DelimiterHex=3a
- ◀ pw /MEDIA/UART/RECOGNIZER.DelimiterHex=3a

7.9.3. Set the Timeout

When the set time is elapsed after the last received message, the device saves the data. It can be applied, when there is no special or easily defined delimiter string in the incoming serial data, but there is a time gap between the messages.

- ▶ SET·/MEDIA/UART/RECOGNIZER.Timeout=<timeout>
- ◀ pw·/MEDIA/UART/RECOGNIZER.Timeout=<timeout>

Parameters

<timeout> Timeout value in ms.; 0: disable the timeout; minimum value: 10.

Example

- ▶ SET /MEDIA/UART/RECOGNIZER.Timeout=20
- ◀ pw /MEDIA/UART/RECOGNIZER.Timeout=20

7.9.4. Query the Last Recognized Serial Message in String Format

The recognized data is stored in string format. They are stored until the next incoming message or until the RECOGNIZER:clear() method is called.

TIPS AND TRICKS: When one of these properties are set as a condition in the Event Manager, and the same strings follow each other, the action **will execute once**.

Command and Response

- ▶ GET·/MEDIA/UART/RECOGNIZER.Rx
- ◀ pr·/MEDIA/UART/RECOGNIZER.Rx=<recognized_string>

Parameters

<recognized_string> Max. 12 byte-long recognized data string.

Example

- ▶ GET /MEDIA/UART/RECOGNIZER.Rx
- ◀ pr /MEDIA/UART/RECOGNIZER.Rx=Login:
#recognizer_lw3 #rs232recognizer_lw3 #rs-232recognizer_lw3 #new

7.9.5. Query the Last Recognized Serial Message in Hex Format

The recognized data is stored in hex format. They are stored until the next incoming message or until the RECOGNIZER:clear() method is called.

TIPS AND TRICKS: When one of these properties are set as a condition in the Event Manager, and the same strings follow each other, the action **will execute once**.

Command and Response

- ▶ GET·/MEDIA/UART/RECOGNIZER.RxHex
- ◀ pr·/MEDIA/UART/RECOGNIZER.RxHex=<recognized_hex>

Parameters

<recognized_hex> Recognized data in hex format.

Example

- ▶ GET /MEDIA/UART/RECOGNIZER.RxHex
- ◀ pr /MEDIA/UART/RECOGNIZER.RxHex=FF1F4C6F67696E3A

7.9.6. Query the Last Recognized Serial Message in Hash Format

The recognized data is stored in hash format. They are stored until the next incoming message or until the RECOGNIZER:clear() method is called.

TIPS AND TRICKS: When one of these properties are set as a condition in the Event Manager, and the same strings follow each other, the action **will execute once**.

Command and Response

- ▶ GET·/MEDIA/UART/RECOGNIZER.Hash
- ◀ pr·/MEDIA/UART/RECOGNIZER.Hash=<recognized_hash>

Parameters

<recognized_hash> Fingerprint code, Max. 32 bit-long recognized data hash.

Example

- ▶ GET /MEDIA/UART/RECOGNIZER.Hash
- ◀ pr /MEDIA/UART/RECOGNIZER.Hash=997A659E

7.9.7. Clear the Stored Last Recognized Serial Message

This method deletes all the stored received serial messages.

Command and Response

- ▶ CALL /MEDIA/UART/RECOGNIZER:clear()
- ◀ mO /MEDIA/UART/RECOGNIZER:clear

Example

- ▶ CALL /MEDIA/UART/RECOGNIZER:clear()
- ◀ mO /MEDIA/UART/RECOGNIZER:clear

7.9.8. Query the Last Recognized Serial Message in String Format

The recognized data is stored in string, hex and hash format in a **temporary** storage. They are erased when the Active Timeout elapsed.

TIPS AND TRICKS: When these properties are set as a condition in the Event Manager, and the same strings follow each other, the action **will execute every occasion** if the active timeout set properly.

Command and Response

- ▶ GET /MEDIA/UART/RECOGNIZER.ActiveRx
- ◀ pr /MEDIA/UART/RECOGNIZER.ActiveRx=<recognized _string>

Parameters

<recognized _string> Max. 12 byte-long recognized data string.

Example

- ▶ GET /MEDIA/UART/RECOGNIZER.ActiveRx
- ◀ pr /MEDIA/UART/RECOGNIZER.ActiveRx=Login:

7.9.9. Query the Last Recognized Serial Message in Hex Format

The recognized data is stored in string, hex and hash format in a **temporary** storage. They are erased when the Active Timeout elapsed.

TIPS AND TRICKS: When these properties are set as a condition in the Event Manager, and the same strings follow each other, the action **will execute every occasion** if the active timeout set properly.

Command and Response

- ▶ GET /MEDIA/UART/RECOGNIZER.ActiveRxHex
- ◀ pr /MEDIA/UART/RECOGNIZER.ActiveRxHex=<recognized _hex>

Parameters

<recognized _hex> Recognized data in hex format.

Example

- ▶ GET /MEDIA/UART/RECOGNIZER.ActiveRxHex
- ◀ pr /MEDIA/UART/RECOGNIZER.ActiveRxHex= 4C6F67696E3A

7.9.10. Query the Last Recognized Serial Message in Hash Format

The recognized data is stored in string, hex and hash format in a **temporary** storage. They are erased when the Active Timeout elapsed.

TIPS AND TRICKS: When these properties are set as a condition in the Event Manager, and the same strings follow each other, the action **will execute every occasion** if the active timeout set properly.

Command and Response

- ▶ GET /MEDIA/UART/RECOGNIZER.ActiveHash
- ◀ pr /MEDIA/UART/RECOGNIZER.ActiveHash=<recognized _hash>

Parameters

<recognized _hash> Fingerprint code, Max. 32 bit-long recognized data hash.

Example

- ▶ GET /MEDIA/UART/RECOGNIZER.ActiveHash
 - ◀ pr /MEDIA/UART/RECOGNIZER.ActiveHash= 2D8A5E38
- #infra_lw3 #infrared_lw3 #new

7.9.11. Set the Active Timeout

This property is responsible for erasing the temporary storage (ActiveRx, ActiveRxHex, ActiveHash) after the elapsing time. Default value is 50ms.

Command and Response

- ▶ SET /MEDIA/UART/RECOGNIZER.ActivePropertyTimeout=<a_timeout>
- ◀ pw /MEDIA/UART/RECOGNIZER.ActivePropertyTimeout=<a_timeout>

Parameters

<a_timeout> Active timeout value (ms) between 0 and 255.

Example

- ▶ SET /MEDIA/UART/RECOGNIZER.ActivePropertyTimeout=255
- ◀ pw /MEDIA/UART/RECOGNIZER.ActivePropertyTimeout=255

7.10. Infrared Port Configuration

INFO: Infrared input and output port numbering can be found in the [Input/Output Port Numbering](#) section.

Parameters

Parameter	Description
<in>	IR input port, example: S1
<out>	IR output port, example: D1

7.10.1. Enable Command Injection Mode

Command and Response

- ▶ SET /MEDIA/IR/<in|out>.CommandInjectionEnable=<logical_value>
- ◀ pw /MEDIA/IR/<in|out>.CommandInjectionEnable=<logical_value>

Parameters

Identifier	Parameter description	Value	Explanation
<logical_value>	Command injection setting	true	CI is enabled.
		false	CI is disabled.

Example

- ▶ SET /MEDIA/IR/S1.CommandInjectionEnable=true
- ◀ pw /MEDIA/IR/S1.CommandInjectionEnable=true

7.10.2. Change Command Injection Port Number

Command and Response

- ▶ SET·/MEDIA/IR/<in|out>.CommandInjectionPort=<port_no>
- ◀ pw·/MEDIA/IR/<in|out>.CommandInjectionPort=<port_no>

Example

- ▶ SET /MEDIA/IR/S1.CommandInjectionPort=9001
- ◀ pw /MEDIA/IR/S1.CommandInjectionPort=9001

7.10.3. Enable/Disable Output Signal Modulation

Command and Response

- ▶ SET·/MEDIA/IR/<out>.EnableModulation=<logical_value>
- ◀ pw·/MEDIA/IR/<out>.EnableModulation=<logical_value>

Parameters

Identifier	Parameter description	Value	Explanation
<logical_value>	Signal modulation enable/disable setting	true	The signal modulation is enabled.
		false	The signal modulation is disabled.

Example

- ▶ SET /MEDIA/IR/D1.EnableModulation=false
- ◀ pw /MEDIA/IR/D1.EnableModulation=false

Signal modulation is turned off on IR output (D1).

■ INFO: The default setting value is **true** (enabled).

7.11. Sending Message via the Communication Ports

7.11.1. Sending a TCP Message (ASCII-format) via TCP Port

The command is for sending a command message in ASCII-format. This method allows escaping the control characters. For more information see the [Escaping](#) section.

Command and Response #message_lw3

- ▶ CALL·/MEDIA/ETHERNET:tcpMessage(<IP_address>:<port_no>=<message>)
- ◀ mO·/MEDIA/ETHERNET:tcpMessage

Example

- ▶ CALL /MEDIA/ETHERNET:tcpMessage(192.168.0.103:6107=C00)
- ◀ mO /MEDIA/ETHERNET:tcpMessage

The 'C00' message is sent to the indicated IP:port address.

Example with HEX codes

- ▶ CALL /MEDIA/ETHERNET:tcpMessage(192.168.0.20:5555=C00\x0a\x0d)
- ◀ mO /MEDIA/ETHERNET:tcpMessage

The 'C00' message with CrLf (Carriage return and Line feed) is sent to the indicated IP:port address. The \x sequence indicates the HEXA code; see more information in the [Using Hexadecimal Codes](#) section.

7.11.2. Sending a TCP Text (ASCII-format) via TCP Port

The command is for sending a text message in ASCII-format. This method **does not allow** sending message with control and non-printable characters.

Command and Response

- ▶ CALL·/MEDIA/ETHERNET:tcpText(<IP_address>:<port_no>=<text>)
- ◀ mO·/MEDIA/ETHERNET:tcpText

Example

- ▶ CALL /MEDIA/ETHERNET:tcpText(192.168.0.103:6107=pwr_on)
- ◀ mO /MEDIA/ETHERNET:tcpText

Explanation

The 'pwr_on' text is sent to the indicated IP:port address.

7.11.3. Sending a TCP Binary Message (HEX-format) via TCP Port

The command is for sending a binary message in Hexadecimal format. This method **does not require escaping** the control and non-printable characters.

Command and Response

- ▶ CALL·/MEDIA/ETHERNET:tcpBinary(<IP_address>:<port_no>=<HEX_message>)
- ◀ mO·/MEDIA/ETHERNET:tcpBinary

Example

- ▶ CALL /MEDIA/ETHERNET:tcpBinary(192.168.0.103:6107=0100000061620000cdcc2c40)
- ◀ mO /MEDIA/ETHERNET:tcpBinary

Explanation

The '0100000061620000cdcc2c40' message is sent to the indicated IP:port address.

■ INFO: There is no need to insert a space or other separator character between the binary messages.

7.11.4. Sending UDP Message (ASCII-format) via TCP Port

The command is for sending a UDP message in ASCII-format. This method **allows** escaping the control characters. For more information see the [Escaping](#) section.

Command and Response

- ▶ CALL·/MEDIA/ETHERNET:udpMessage(<IP_address>:<port_no>=<message>)
- ◀ mO·/MEDIA/ETHERNET:udpMessage

Example

- ▶ CALL /MEDIA/ETHERNET:udpMessage(192.168.0.103:6107=C00)
- ◀ mO /MEDIA/ETHERNET:udpMessage

The 'C00' message is sent to the indicated IP:port address.

Example with HEX codes

- ▶ CALL /MEDIA/ETHERNET:udpMessage(192.168.0.20:9988=C00\x0a\x0d)
- ◀ mO /MEDIA/ETHERNET:udpMessage

The 'C00' message with CrLf (Carriage return and Line feed) is sent to the indicated IP:port address. The \x sequence indicates the HEXA code; see more information in the [Using Hexadecimal Codes](#) section.

7.11.5. Sending a TCP Text (ASCII-format) via TCP Port

The command is for sending a text message in ASCII-format via UDP-protocol. This method **does not allow** sending message with control and non-printable characters.

Command and Response

- ▶ CALL·/MEDIA/ETHERNET:udpText(<IP_address>:<port_no>=<text>)
- ◀ mO·/MEDIA/ETHERNET:udpText

Example

- ▶ CALL /MEDIA/ETHERNET:udpText(192.168.0.20:9988=open)
- ◀ mO /MEDIA/ETHERNET:udpText

The 'open' text is sent to the indicated IP:port address.

7.11.6. Sending a UDP Binary Message (HEX-format) via TCP Port

The command is for sending a binary message in Hexadecimal format via UDP protocol. This method **does not require escaping** the control and non-printable characters.

Command and Response

- ▶ CALL·/MEDIA/ETHERNET:udpBinary(<IP_address>:<port_no>=<HEX_message>)
- ◀ mO·/MEDIA/ETHERNET:udpBinary

Example

- ▶ CALL /MEDIA/ETHERNET:udpBinary(192.168.0.20:9988=433030)
- ◀ mO /MEDIA/ETHERNET:udpBinary

The '433030' message is sent to the indicated IP:port address.

■ INFO: There is no need to insert a space or other separator character between the binary messages.

7.11.7. Sending a Message (ASCII-format) via Serial Port

The command is for sending a command message in ASCII-format. This method **allows** escaping the control characters. For more information see the [Escaping](#) section.

Command and Response

- ▶ CALL·/MEDIA/UART/<port>:sendMessage(<message>)
- ◀ mO·/MEDIA/UART/<port>:sendMessage

Example

- ▶ CALL /MEDIA/UART/P1:sendMessage(PWR0)
- ◀ mO /MEDIA/UART/P1:sendMessage

The 'PWR0' message is sent out via the P1 serial port.

7.12.2. Sending a CEC Command in Text Format

Command and Response

- ▶ CALL /MEDIA/CEC/<port>:send(<command>)
- ◀ mO /MEDIA/CEC/<port>:send

Parameters

The followings are accepted as <command>:

image_view_on	standby	ok	back	up
down	left	right	root_menu	setup_menu
contents_menu	favorite_menu	media_top_menu	media_context_menu	number_0
number_1	number_2	number_3	number_4	number_5
number_6	number_7	number_8	number_9	dot
enter	clear	channel_up	channel_down	sound_select
input_select	display_info	power_legacy	page_up	page_down
volume_up	volume_down	mute_toggle	mute	unmute
play	stop	pause	record	rewind
fast_forward	eject	skip_forward	skip_backward	3d_mode
stop_record	pause_record	play_forward	play_reverse	select_next_media
select_media_1	select_media_2	select_media_3	select_media_4	select_media_5
power_toggle	power_on	power_off	stop_function	f1
f2	f3	f4		

Example

- ▶ CALL /MEDIA/CEC/O1:send(power_on)
- ◀ mO /MEDIA/CEC/O1:send

7.12.3. Sending a CEC Command in Hexadecimal Format

Command and Response

- ▶ CALL /MEDIA/CEC/<port>:sendHex(<hex_code>)
- ◀ mO /MEDIA/CEC/<port>:sendHex

Parameters

<hex_code> Accepted command is max. 30 character long (15 byte) in hexadecimal format.

Example

- ▶ CALL /MEDIA/CEC/I1:sendHex(8700E091)
- ◀ mO /MEDIA/CEC/I1:sendHex

7.13. Relay Port Settings

7.13.1. Query the Connection State

Command and Response #relay_lw3

- ▶ GET·/MEDIA/RELAY/CTRL.Output
- ◀ pr·/MEDIA/RELAY/CTRL.Output=<connection_state>

Parameters

Identifier	Parameter description	Value	Explanation
<connection_state>	Connection state of the relay	O	Opened
		C	Closed

Example

- ▶ GET /MEDIA/RELAY/CTRL.Output
- ◀ pr /MEDIA/RELAY/CTRL.Output=C;O

P1 relay port is closed, the P2 relay port is opened.

7.13.2. Change the Connection State

Command and Response

- ▶ SET·/MEDIA/RELAY/<port>.Output=<connection_state>
- ◀ pw·/MEDIA/RELAY/<port>.Output=<connection_state>

Parameters

See at previous section.

Example

- ▶ SET /MEDIA/RELAY/P1.Output=C
- ◀ pw /MEDIA/RELAY/P1.Output=C

P1 relay port is set to be closed.

7.13.3. Toggle the Connection State

Command and Response

- ▶ CALL·/MEDIA/RELAY/<port>:toggle()
- ◀ mO·/MEDIA/RELAY/<port>:toggle

Example

- ▶ CALL /MEDIA/RELAY/P1:toggle()
- ◀ mO /MEDIA/RELAY/P1:toggle

The connection state of P1 port is **changed to closed** from opened.

7.14. EDID Management

Parameters

Parameter	Description
<emulated>	The emulated EDID memory of the desired input port. Example: E1.
<dynamic>	Dynamic EDID memory index. Example: D1
<user>	User EDID memory index. Example: U1
<factory>	Factory EDID memory index. Example: F1

7.14.1. Query the Emulated EDIDs

Command and Response *#edid_lw3*

- ▶ GET /EDID.EdidStatus
- ◀ pr /EDID.EdidStatus=<dynamic|user|factory>:<emulated>;...;<dynamic|user|factory>:<emulated>

Example

- ▶ GET /EDID.EdidStatus
- ◀ pr /EDID.EdidStatus=D1:E1;D1:E2;D1:E3;D1:E4

Emulated EDID memory for input port is listed with the EDID number that is currently emulated on the input.

7.14.2. Query the Validity of a Dynamic EDID

Command and Response

- ▶ GET /EDID/D/<dynamic>.Validity
- ◀ pr /EDID/D/<dynamic>.Validity=<logical_value>

Parameters

The <logical_value> can be **true** or **false**.

Example

- ▶ GET /EDID/D/D1.Validity
- ◀ pr /EDID/D/D1.Validity=true

7.14.3. Query the Preferred Resolution of an User EDID

Command and Response

- ▶ GET /EDID/U/<user>.PreferredResolution
- ◀ pr /EDID/U/<user>.PreferredResolution=<resolution>

Example

- ▶ GET /EDID/U/U2.PreferredResolution
- ◀ pr /EDID/U/U2.PreferredResolution=1920x1080p60.00Hz

7.14.4. Emulating an EDID to an Input Port

Command and Response

- ▶ CALL /EDID:switch(<dynamic|user|factory>:<emulated>)
- ◀ mO /EDID:switch

Example

- ▶ CALL /EDID:switch(F49:E2)
- ◀ mO /EDID:switch

7.14.5. Emulating an EDID to All Input Ports

Command and Response

- ▶ CALL /EDID:switchAll(<dynamic|user|factory>)
- ◀ mO /EDID:switchAll

Example

- ▶ CALL /EDID:switchAll(F47)
- ◀ mO /EDID:switchAll

7.14.6. Copy an EDID to User Memory

Command and Response

- ▶ CALL /EDID:copy(<dynamic|emulated|factory|user>:<user>)
- ◀ mO /EDID:copy

Example

- ▶ CALL /EDID:copy(D1:U1)
- ◀ mO /EDID:copy

The EDID of the last connected sink of D1 (Output 1) has been copied to U1.

7.14.7. Deleting an EDID from User Memory

Command and Response

- ▶ CALL·/EDID:delete(<user>)
- ◀ mO·/EDID:delete

Example

- ▶ CALL /EDID:delete(U1)
- ◀ mO /EDID:delete

7.14.8. Resetting the Emulated EDIDs

Command and Response

- ▶ CALL·/EDID:reset()
- ◀ mO·/EDID:reset

Example

- ▶ CALL /EDID:reset()
- ◀ mO /EDID:reset

Calling this method switches all emulated EDIDs to factory default one. See the table in the [Factory EDID List](#) section.

7.15. LW3 Commands - Quick Summary

System Commands

Query the Product Name

- ▶ GET·/.ProductName

Set the Device Label

- ▶ SET·/MANAGEMENT/UID/DeviceLabel=<Custom_name>

Query the Serial Number

- ▶ GET·/.SerialNumber

Query the Firmware Version

- ▶ GET·/SYS/MB.FirmwareVersion

Identify the Device

- ▶ CALL·/MANAGEMENT/UI:identifyMe()

Dark Mode

- ▶ SET·/MANAGEMENT/UI/DARKMODE.DarkModeEnable=<status>

Restarting the Device

- ▶ CALL·/SYS:reset()

Restore the Factory Default Settings

- ▶ CALL·/SYS:factoryDefaults()

Video Port Settings

Query the Status of Source Ports

- ▶ GET·/MEDIA/VIDEO/XP.SourcePortStatus

Query the Status of Destination Port

- ▶ GET·/MEDIA/VIDEO/XP.DestinationPortStatus

Mute Input

- ▶ CALL·/MEDIA/VIDEO/XP:muteSource(<in>)

Unmute Input

- ▶ CALL·/MEDIA/VIDEO/XP:unmuteSource(<in>)

Lock Input

- ▶ CALL·/MEDIA/VIDEO/XP:lockSource(<in>)

Unlock Input

- ▶ CALL·/MEDIA/VIDEO/XP:unlockSource(<in>)

Mute Output

- ▶ CALL·/MEDIA/VIDEO/XP:muteDestination(<out>)

Unmute Output

- ▶ CALL·/MEDIA/VIDEO/XP:unmuteDestination(<out>)

Lock Output

- ▶ CALL·/MEDIA/VIDEO/XP:lockDestination(<out>)

Unlock Output

- ▶ CALL·/MEDIA/VIDEO/XP:unlockDestination(<out>)

HDCP Setting (Input Port)

- ▶ SET·/MEDIA/VIDEO/<in>.HdcpEnable=<logical_value>

HDCP Setting (Output Port)

- ▶ SET·/MEDIA/VIDEO/<out>.HdcpModeSetting=<HDCP_mode>

Test Pattern Generator Mode

- ▶ SET·/MEDIA/VIDEO/<out>.TpgMode=<mode>

Test Pattern Generator Clock Source

- ▶ SET·/MEDIA/VIDEO/<out>.TpgClockSource=<clock_frequency>

Test Pattern Setting

- ▶ SET·/MEDIA/VIDEO/<out>.TpgPattern=<pattern>

HDMI Mode Settings (Output Port)

- ▶ SET·/MEDIA/VIDEO/<out>.HdmiModeSetting=<mode>

Query the Recent TPS Mode

- ▶ GET·/REMOTE/<port>.tpsMode

TPS Mode Settings

- ▶ SET·/REMOTE/<port>.tpsModeSetting=<TPS_mode>

Audio Port Settings

Query the Status of Source Ports

- ▶ GET·/MEDIA/AUDIO/XP.SourcePortStatus

Query the Status of Destination Port

- ▶ GET·/MEDIA/AUDIO/XP.DestinationPortStatus

Mute Input

- ▶ CALL·/MEDIA/AUDIO/XP:muteSource(<in>)

Unmute Input

- ▶ CALL·/MEDIA/AUDIO/XP:unmuteSource(<in>)

Lock Input

- ▶ CALL·/MEDIA/AUDIO/XP:lockSource(<in>)

Unlock Input

- ▶ CALL·/MEDIA/AUDIO/XP:unlockSource(<in>)

Mute Output

- ▶ CALL·/MEDIA/AUDIO/XP:muteDestination(<out>)

Unmute Output

- ▶ CALL·/MEDIA/AUDIO/XP:unmuteDestination(<out>)

Lock Output

- ▶ CALL·/MEDIA/AUDIO/XP:lockDestination(<out>)

Unlock Output

- ▶ CALL·/MEDIA/AUDIO/XP:unlockDestination(<out>)

Analog Audio Output Settings**Volume Setting (dB)**

- ▶ SET·/MEDIA/AUDIO/<out>.VolumedB=<level>

Volume Setting (dB) in Steps

- ▶ CALL·/MEDIA/AUDIO/<out>.stepVolumedB(<step>)

Volume Setting (Percent)

- ▶ SET·/MEDIA/AUDIO/<out>.VolumePercent=<percent>

Volume Setting (Percent) in Steps

- ▶ CALL·/MEDIA/AUDIO/<out>.stepVolumePercent(<percent>)

Balance Setting

- ▶ SET·/MEDIA/AUDIO/<out>.Balance=<level>

Balance Setting in Steps

- ▶ CALL·/MEDIA/AUDIO/<out>.stepBalance(<level>)

Network Configuration**Query the DHCP State**

- ▶ GET·/MANAGEMENT/NETWORK.DhcpEnabled

Change the DHCP State

- ▶ SET·/MANAGEMENT/NETWORK.DhcpEnabled=<logical_value>

Query the IP Address

- ▶ GET·/MANAGEMENT/NETWORK.IpAddress

Change the IP Address (Static)

- ▶ SET·/MANAGEMENT/NETWORK.StaticIpAddress=<IP_address>

Query the Subnet Mask

- ▶ GET·/MANAGEMENT/NETWORK.NetworkMask

Change the Subnet Mask (Static)

- ▶ SET·/MANAGEMENT/NETWORK.StaticNetworkMask=<netmask>

Query the Gateway Address

- ▶ GET·/MANAGEMENT/NETWORK.GatewayAddress

Change the Gateway Address (Static)

- ▶ SET·/MANAGEMENT/NETWORK.StaticGatewayAddress=<gw_address>

Query the MAC Address

- ▶ GET·/MANAGEMENT/NETWORK.MacAddress

Apply Network Settings

- ▶ CALL·/MANAGEMENT/NETWORK.ApplySettings()

RS-232 Port Configuration**Protocol Setting**

- ▶ SET·/MEDIA/UART/<port>.ControlProtocol=<protocol>

BAUD Rate Setting

- ▶ SET·/MEDIA/UART/<port>.Baudrate=<baudrate>

Databits Setting

- ▶ SET·/MEDIA/UART/<port>.DataBits=<databits>

Stopbits Setting

- ▶ SET·/MEDIA/UART/<port>.StopBits=<stopbits>

Parity Setting

- ▶ SET·/MEDIA/UART/ <port>.Parity=<parity>

RS-232 Operation Mode

- ▶ SET·/MEDIA/UART/<port>.Rs232Mode=<mode>

Query the Command Injection Mode

- ▶ GET·/MEDIA/UART/<port>.CommandInjectionStatus

Change the Command Injection Mode

- ▶ SET:/MEDIA/UART/<port>.CommandInjectionEnable=<logical_value>

RS-232 Recognizer

Enable the Recognizer

- ▶ SET:/MEDIA/UART/<port>.RecognizerEnable=<logical_value>

Set the Delimiter Hex

- ▶ SET:/MEDIA/UART/RECOGNIZER.DelimiterHex=<delimiter>

Set the Timeout

- ▶ SET:/MEDIA/UART/RECOGNIZER.TimeOut=<timeout>

Query the Last Recognized Serial Message in String Format

- ▶ GET:/MEDIA/UART/RECOGNIZER.Rx

Query the Last Recognized Serial Message in Hex Format

- ▶ GET:/MEDIA/UART/RECOGNIZER.RxHex

Query the Last Recognized Serial Message in Hash Format

- ▶ GET:/MEDIA/UART/RECOGNIZER.Hash

Clear the Stored Last Recognized Serial Message

- ▶ CALL:/MEDIA/UART/RECOGNIZER:clear()

Query the Last Recognized Serial Message in String Format

- ▶ GET:/MEDIA/UART/RECOGNIZER.ActiveRx

Query the Last Recognized Serial Message in Hex Format

- ▶ GET:/MEDIA/UART/RECOGNIZER.ActiveRxHex

Query the Last Recognized Serial Message in Hash Format

- ▶ GET:/MEDIA/UART/RECOGNIZER.ActiveHash

Set the Active Timeout

- ▶ SET:/MEDIA/UART/RECOGNIZER.ActivePropertyTimeout=<a_timeout>

Infrared Port Configuration

Enable Command Injection Mode

- ▶ SET:/MEDIA/IR/<in|out>.CommandInjectionEnable=<logical_value>

Change Command Injection Port Number

- ▶ SET:/MEDIA/IR/<in|out>.CommandInjectionPort=<port_no>

Enable/Disable Output Signal Modulation

- ▶ SET:/MEDIA/IR/<out>.EnableModulation=<logical_value>

Sending Message via the Communication Ports

Sending a TCP Message (ASCII-format) via TCP Port

- ▶ CALL:/MEDIA/ETHERNET:tcpMessage(<IP_address>:<port_no>=<message>)

Sending a TCP Text (ASCII-format) via TCP Port

- ▶ CALL:/MEDIA/ETHERNET:tcpText(<IP_address>:<port_no>=<text>)

Sending a TCP Binary Message (HEX-format) via TCP Port

- ▶ CALL:/MEDIA/ETHERNET:tcpBinary(<IP_address>:<port_no>=<HEX_message>)

Sending UDP Message (ASCII-format) via TCP Port

- ▶ CALL:/MEDIA/ETHERNET:udpMessage(<IP_address>:<port_no>=<message>)

Sending a TCP Text (ASCII-format) via TCP Port

- ▶ CALL:/MEDIA/ETHERNET:udpText(<IP_address>:<port_no>=<text>)

Sending a UDP Binary Message (HEX-format) via TCP Port

- ▶ CALL:/MEDIA/ETHERNET:udpBinary(<IP_address>:<port_no>=<HEX_message>)

Sending a Message (ASCII-format) via Serial Port

- ▶ CALL:/MEDIA/UART/<port>:sendMessage(<message>)

Sending a Text (ASCII-format) via Serial Port

- ▶ CALL:/MEDIA/UART/<port>:sendText(<message>)

Sending a Binary Message (HEX-format) via Serial Port

- ▶ CALL:/MEDIA/UART/<port>:sendBinaryMessage(<message>)

Using Hexadecimal Codes

Sending Pronto Hex Codes in Little-endian Format via IR Port

- ▶ CALL:/MEDIA/IR/<output_port>:sendProntoHex(<hex_code>)

Sending Pronto Hex Codes in Big-endian Format via IR Port

- ▶ CALL:/MEDIA/IR/<output_port>:sendProntoHexBigEndian(<hex_code>)

Sending CEC Commands

Sending an OSD String

- ▶ SET:/MEDIA/CEC/<port>.OsdString=<text>
- ▶ CALL:/MEDIA/CEC/<port>:send(set_osd)

Sending a CEC Command in Text Format

- ▶ CALL /MEDIA/CEC/<port>:send(<command>)

Sending a CEC Command in Hexadecimal Format

- ▶ CALL /MEDIA/CEC/<port>:sendHex(<hex_code>)

Relay Port Settings

Query the Connection State

- ▶ GET-/MEDIA/RELAY/CTRL.Output

Change the Connection State

- ▶ SET-/MEDIA/RELAY/<port>.Output=<connection_state>

Toggle the Connection State

- ▶ CALL-/MEDIA/RELAY/<port>.toggle()

EDID Management

Query the Emulated EDIDs

- ▶ GET-/EDID.EdidStatus

Query the Validity of a Dynamic EDID

- ▶ GET-/EDID/D/<dynamic>.Validity

Query the Preferred Resolution of a User EDID

- ▶ GET-/EDID/U/<user>.PreferredResolution

Emulating an EDID to an Input Port

- ▶ CALL-/EDID:switch(<dynamic|user|factory>:<emulated>)

Emulating an EDID to All Input Ports

- ▶ CALL-/EDID:switchAll(<dynamic|user|factory>)

Copy an EDID to User Memory

- ▶ CALL-/EDID:copy(<dynamic|emulated|factory|user>:<user>)

Deleting an EDID from User Memory

- ▶ CALL-/EDID:delete(<user>)

Resetting the Emulated EDIDs

- ▶ CALL-/EDID:reset()

8

Firmware Upgrade

The receiver can be upgraded by using Lightware Device Updater V2 (LDU2) software via Ethernet. The firmware pack with the necessary components (*.lfp2 file) for your specific product, the LDU2 application, and the User's manual can be downloaded from the Support page of our website www.lightware.com.

- ▶ [ABOUT THE FIRMWARE PACKAGE \(LFP2 FILE\)](#)
- ▶ [SHORT INSTRUCTIONS](#)
- ▶ [INSTALLATION OF LDU2](#)
- ▶ [DETAILED INSTRUCTIONS](#)
- ▶ [KEEPING THE CONFIGURATION SETTINGS](#)
- ▶ [REMOTE FIRMWARE UPGRADE OF CONNECTED LIGHTWARE DEVICES](#)

ATTENTION! While the firmware is being upgraded, the normal operation mode is suspended as the receiver is switched to bootload mode. Signal processing is not performed. Do not interrupt the firmware upgrade. If any problem occurs, reboot the receiver and restart the process.

ATTENTION! The firmware upgrade process has an effect on the configuration and the settings of the device. For more details, please see the [Keeping the Configuration Settings](#) section before the upgrade.

8.1. About the Firmware Package (LFP2 File)

The firmware files are packed in an LFP2 package. You need only this file to do the upgrade on your device.

- The package contains all the necessary components, binary, and other files;
- The package also contains each firmware with version number and a list showing the compatible devices.

8.2. Short Instructions

Step 1. Get the firmware pack and the Lightware Device Updater v2 (LDU2) application.

Step 2. Install the LDU2 application.

Step 3. Establish connection between the computer and the device(s) via Ethernet.

Step 4. Start LDU2 and follow the instructions shown on the screen.

8.3. Installation of LDU2

Minimum System Requirement

RAM: 1 GB

Installation Modes

LDU2 has two installation modes: **Normal** and **Snapshot**.

Normal install	Snapshot install
Available for Windows and macOS	Available for Windows
The installer can update only this instance	Cannot be updated
Only one updateable instance can exist for all users	More than one different version can be installed for each user

Comparison of install types

ATTENTION! Using the Normal install as the default value is highly recommended.

Installation for Windows OS

Run the installer. If the User Account Control drops a pop-up message click **Yes**. During the installation you will be prompted to select the type of the installation.

Installation for macOS

Mount the DMG file with double clicking on it and drag the LDU2 icon over the Applications icon to copy the program into the Applications folder. If you want to copy the LDU2 into another location just drag the icon over the desired folder.

INFO: After the installation the Windows and the macOS application has the same look and functionality.

8.4. Detailed Instructions

8.4.1. Establish Connection

Make sure that the computer and the device are connected over Ethernet and the connection is established between them.

8.4.2. Start the LDU2 Application and Follow the Steps

The Steps of the Upgrade in Quick Summary:

Step 1. Select the firmware package file.

Step 2. Select the unit(s) for upgrading.

Step 3. Check the upgrade parameters.

Step 4. Start the update and wait until it is finished.

Step 5. Wait until the unit reboots with the new firmware.

Discovering the Devices

After launching LDU2 the device discovery an empty window appears. Click on the **Search for devices** button to start finding the Lightware devices on the network.

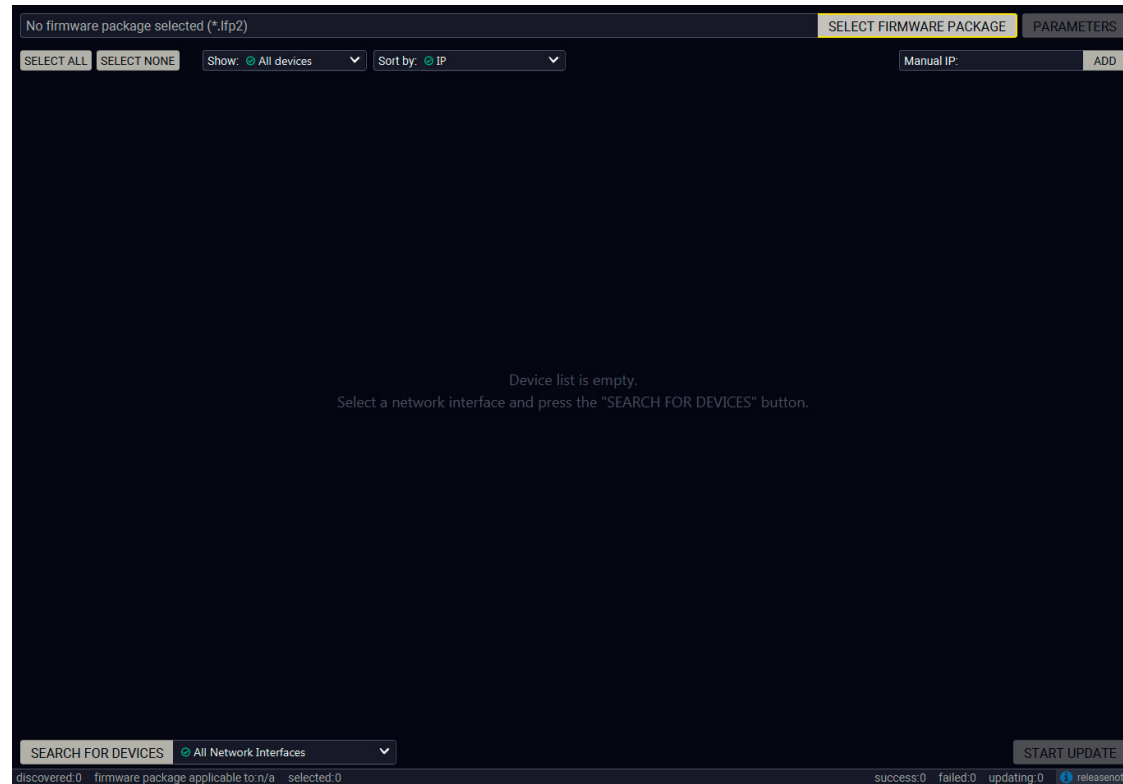

Device discovery is in progress in LDU2

Device List

When the discovery has completed, the devices available on the network are listed in the application.

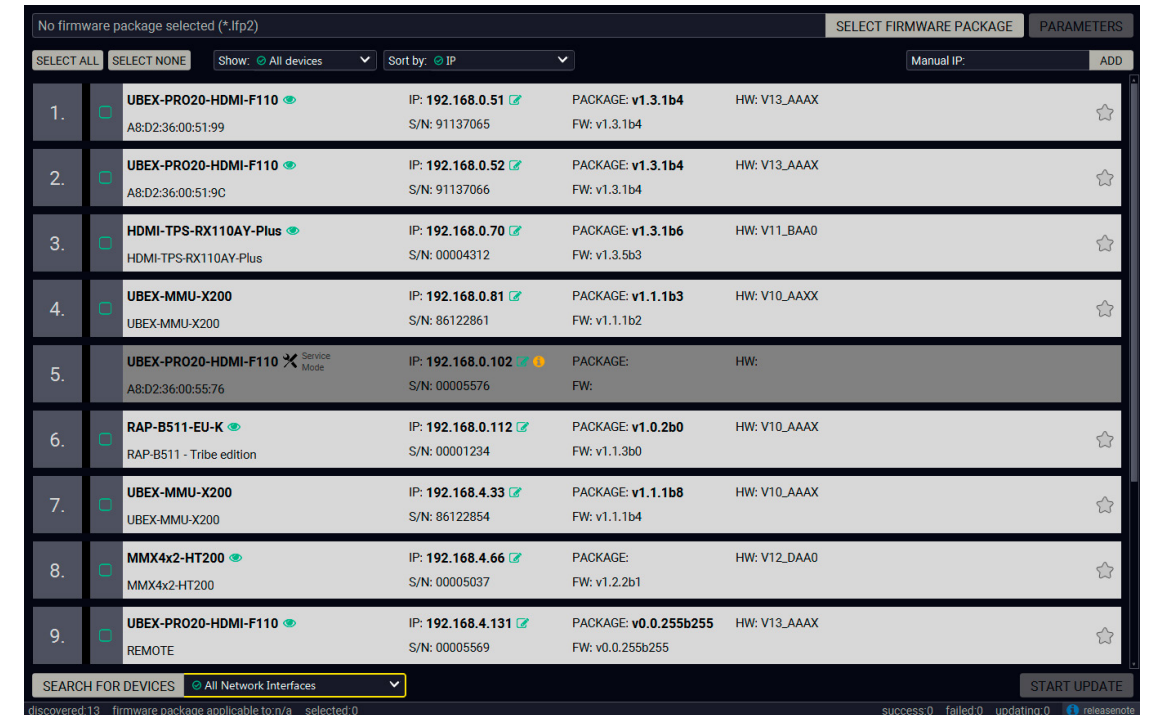

Legend of the Icons

Icon	Name	Description
	Identify the device	Clicking on the icon causes all front panel LEDs blink in green for 10 seconds. The feature helps to identify the device itself in the rack shelf.
	IP address editor	To modify IP address settings quickly it is not necessary to enter the device's settings/network menu, you can set them by clicking the pencil icon beside the IP address.
	Further information available	Device is unreachable. Change the IP address using the front panel LCD menu or the IP address editor of the LDU2.
	Service mode	The device is in bootload (service) mode. The firmware upgrade procedure can be continued in this mode.
	Favorite device	Frequently used devices can be highlighted with the star icon as favorite unit. In this case the star becomes orange filled.

Upgrade Steps

Step 1. Select the firmware package.

Click on the **Select Firmware Package** button and navigate to the location where the LFP2 file of the device is saved. When you click on the name of package, the preview of the release notes are displayed on the right side.

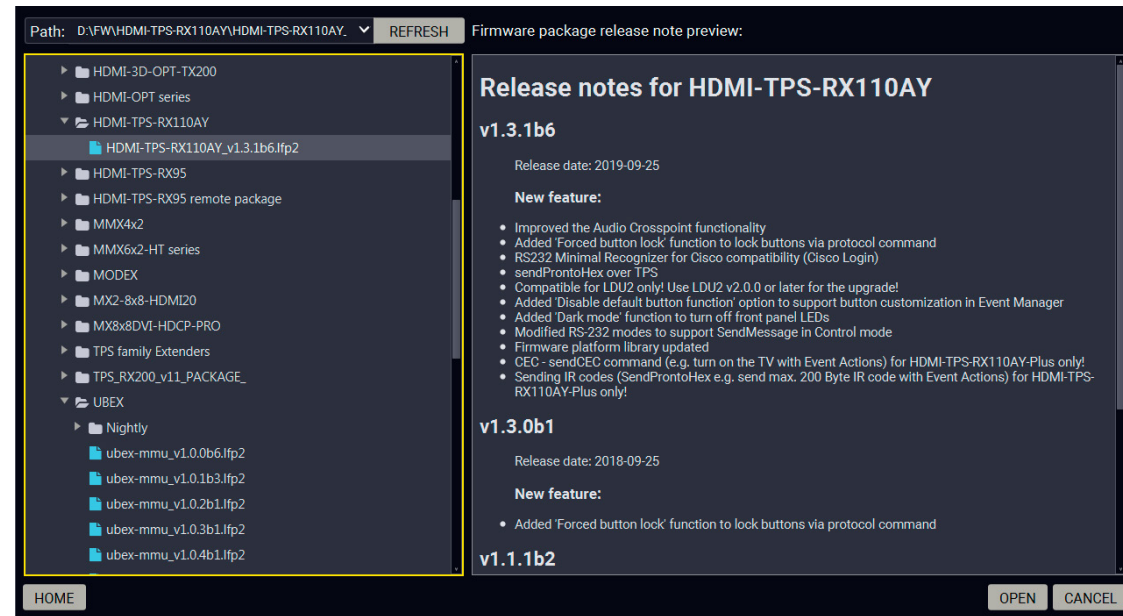

Firmware file browser and the release notes window

After the package file is loaded, the list is filtered to show compatible devices only. The current firmware version of the device is highlighted in orange if it is different from the version of the package loaded.

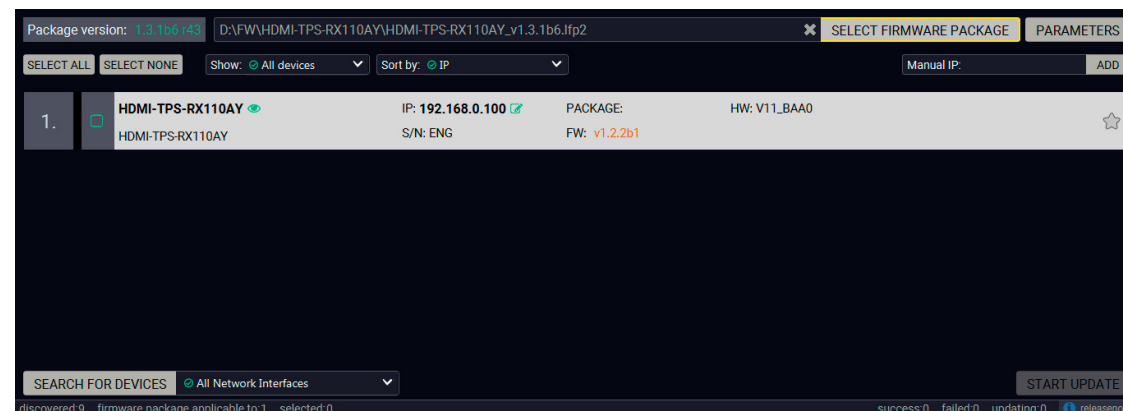

Filtered device list based on the selected firmware package

Step 2. Select the unit for upgrading.

Pick the device for upgrading. The selected line will be highlighted in green.

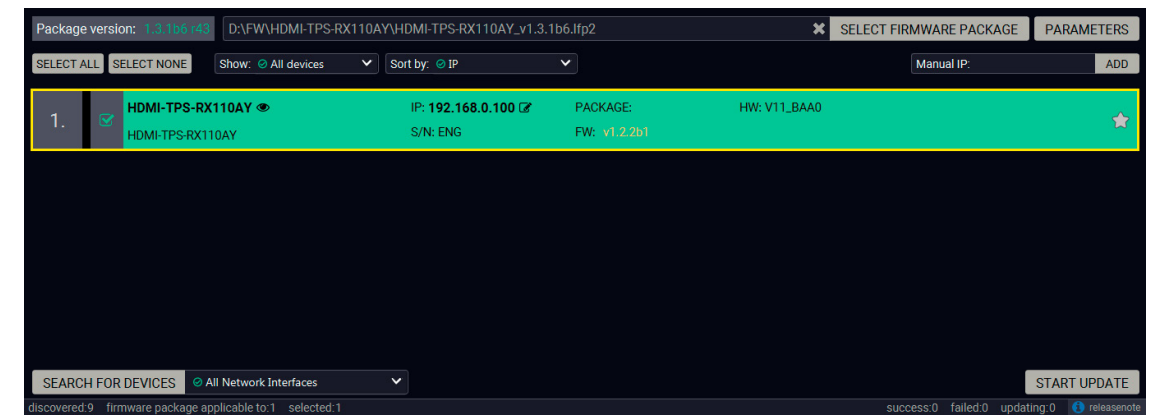

The unit is selected for upgrading

TIPS AND TRICKS: If you are not sure which device is connected to your controller device directly, use the **Identify me** feature clicking on the  button. It makes the four front panel LEDs blink in green for 10 seconds. The feature helps to identify the device itself in the rack shelf or on the desk.

Step 3. Check the upgrade parameters.

ATTENTION! The default settings in the Parameters window should be fine for most cases. Please do not modify them if it is not necessary.

Click on the **Parameters** button to configure the firmware upgrade.

Backup and Restore settings

Restore device configuration: restore device configuration from the backup file created at the beginning of the update process.

Factory default: if it is selected, all user settings and parameters will be cleared and the factory default settings will be applied to the device when the upgrade is done. See the whole list of factory default settings of the endpoint device in the [Factory Default Settings](#) section.

Once the parameters are set, click on the **Apply** button to save the settings.

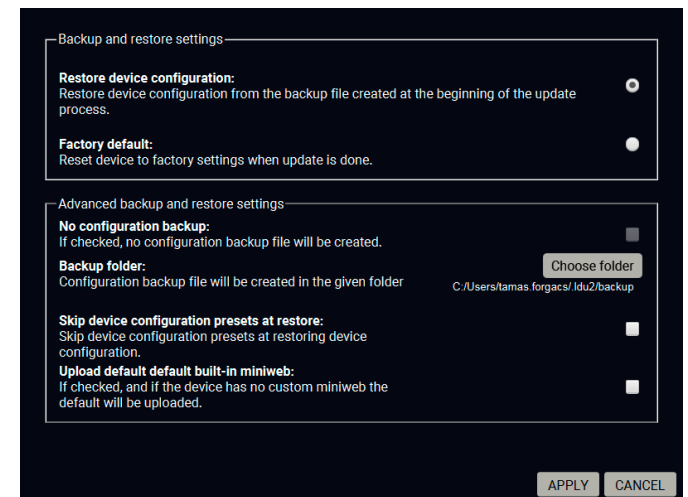

Step 4. Start the update and wait until it is finished.

Click on the **Start Update** button to start the procedure. The status is shown in percent in the right side of the device line and the status of the all procedures in the lower light green progress bar.

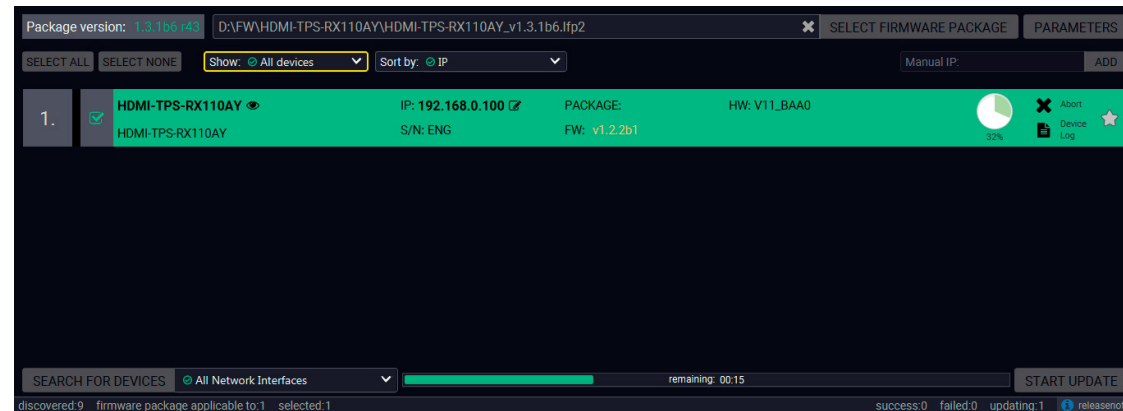

Firmware upgrade is in progress

INFO: The device might reboot several times during the firmware upgrade procedure.

Step 5. Wait until the unit reboots with the new firmware.

Once the firmware upgrade procedure is completed, the unit reboot with the new firmware.

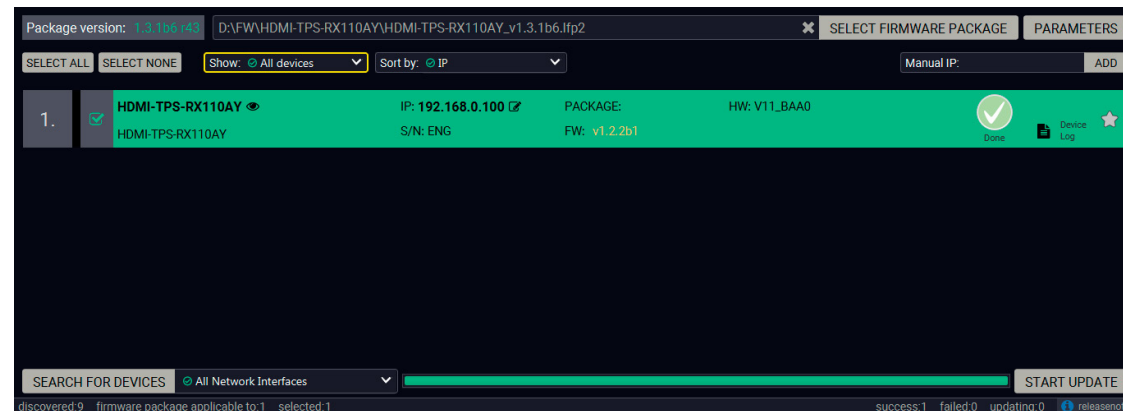

Firmware upgrade procedure is done

8.5. Keeping the Configuration Settings

By default, device configuration settings are restored when firmware upgrade is finished. If factory reset has been chosen in the parameters window, all device settings will be erased. In the case of factory reset you can save the settings of the device in the Lightware Device Controller software and restore it later. See the details in the [Configuration Cloning \(Backup Tab\)](#) section.

The following flow chart demonstrates how this function works in the background.

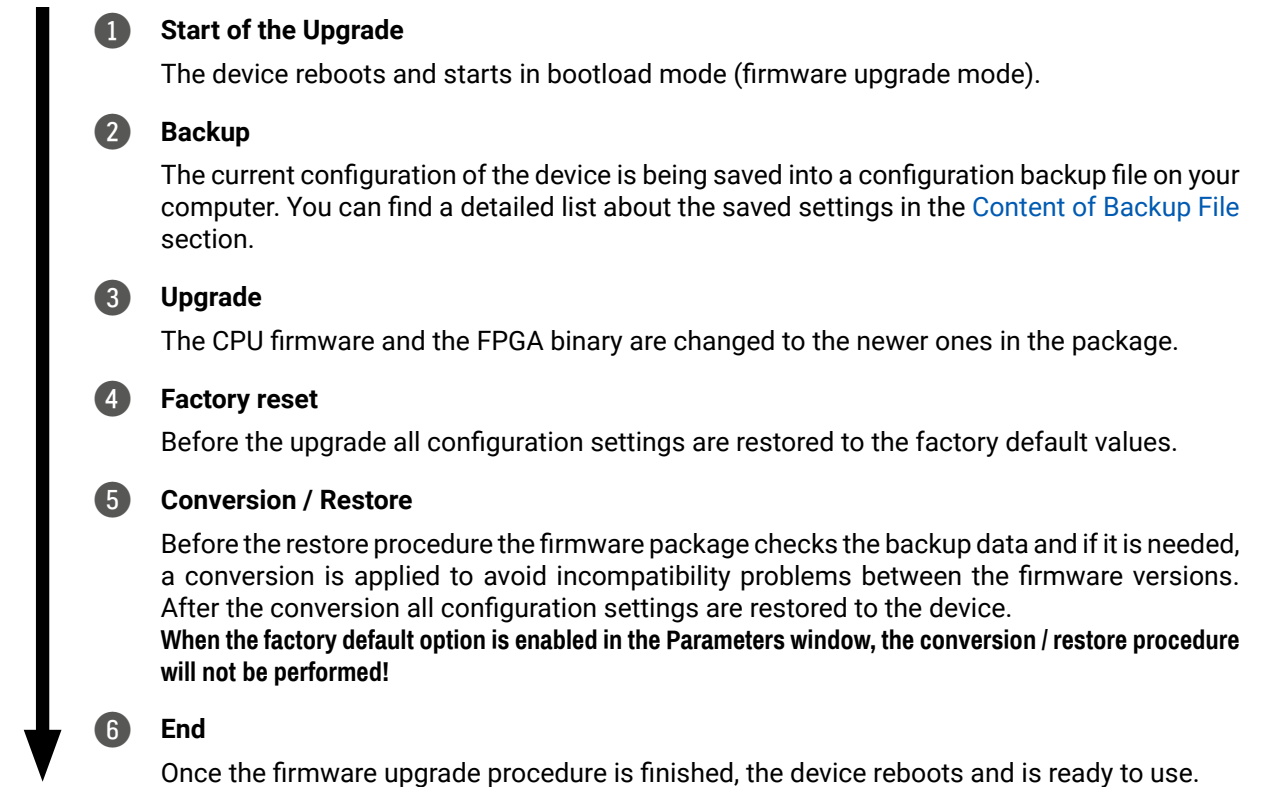

The details about the procedure: when firmware upgrade starts, the first step is making a backup of the settings of the device. The firmware package checks the backup data and if it is needed, a conversion is applied to avoid incompatibility problems between the firmware versions. If you do not want to keep configuration settings, you can set the **Factory default** option enabled.

8.6. Remote Firmware Upgrade of Connected Lightware Devices

Firmware of Lightware devices can be upgraded via another connected Lightware device without removing the device from the system. It means user does not have to connect directly to the upgradable device, it can be reached and flashed through other devices. It's a more comfortable way to keep up-to-date your Lightware devices.



There are two types of remote upgrading:

Extended Upgrade

- Intelligent devices can be upgraded via another intelligent or basic device via TPS or OPTS/OPTM link.
- For example, HDMI-TPS-RX110AY series extenders can be upgraded via MMX6x2-HT series matrix or a HDMI-TPS-TX95 extender.

Hosted Upgrade





- Basic devices can be upgraded only via an intelligent device via TPS link.
- For example, TPS 95 series extenders can be upgraded via MMX6x2-HT series matrix or HDMI-TPS-RX110AY series extenders.
- In case of hosted upgrade, the procedure is almost the same as described in Firmware upgrade – [Start the LDU2 Application and Follow the Steps](#). The only difference is that the host device's name, and IP address appears beside the name of the device to be upgraded.

ATTENTION! During hosted upgrade the host device turned to bootload mode when the extender is upgraded. During the upgrade normal operation mode is suspended. When the upgrade is successfully finished, the normal operation mode is restored.

9

Troubleshooting

Usually, if the system seems not to transport the signal as expected, the best strategy for troubleshooting is to check signal integrity through the whole signal chain starting from source side and moving forward to receiver end.















-  Link to connections/cabling section.
-  Link to front panel operation section.
-  Link to LDC software section.
-  Link to LW2 protocol commands section.
-  Link to LW3 protocol commands section.





















The following sections are available in the chapter:





- ▶ [USE CASE STUDIES](#)
- ▶ [HOW TO SPEED UP THE TROUBLESHOOTING PROCESS](#)

9.1. Use Case Studies

At first, check front panel LEDs and take the necessary steps according to their states. For more information about status, LEDs refer to the [Front View](#) and [Rear View](#) sections.

Symptom	Root cause	Action	Refer to
Video signal			
No picture on the video output	Device or devices are not powered properly	Check the receiver and the other devices if they are properly powered; try to unplug and reconnect them.	 3.3.1
	Cable connection problem	Cables must fit very well, check all the connectors (video and TPS cables).	 3.3
	No incoming signal	If the TPS LINK LED does not light, no signal is present on the TPS input port. Check the source device and the CATx cable.	 3.3
	TPS mode problem	Check the actual TPS mode and the selected modes of the extenders.	 5.4.1
	The output is muted	Check the mute state of output port.	 5.4.1  6.3.5  7.4.2
	Display is not able to receive the video format	Check the emulated EDID; select another (e.g. emulate the EDID of the display on the input port).	 5.6  7.14
	HDCP is disabled	Enable HDCP on the input and output port.	 5.4.1  7.4.11  7.4.12
Not the desired picture displayed on the video output	Video output is set to test pattern (no sync screen) statically	Check Test Pattern settings in the HDMI output properties.	 5.4.1  7.4.13
	Video output is set to test pattern (no sync screen) as there is no picture on video source	Check video settings of the source.	

Symptom	Root cause	Action	Refer to
Audio signal			
No audio is present on output	Source audio volume is low or muted	Check the audio settings of the source.	
	Output port is muted	Check the output port properties.	 5.4.3  6.3.5  7.5.2
	Analog audio volume is set low	Check the Analog audio output port settings (volume).	 5.4.3  7.6
HDMI output signal contains no audio	HDMI mode was set to DVI	Check the properties of the output port and set to HDMI or Auto.	 5.4.1  7.4.16
	DVI EDID is emulated	Check the EDID and select and HDMI EDID to emulate.	 5.6  7.14
RS-232 signal			
Connected serial device does not respond	Cable connection problem	Check the connectors to fit well; check the wiring of the plugs.	 3.3.7
	RS-232 settings are different	Check the port settings of the transmitter and/or the receiver and the connected serial device(s). Pay attention to Link and/or Local ports.	 5.7.1  6.5  7.8
	RS-232 mode is not right	Check the RS-232 mode settings (pass-through, control or command injection)	 5.7.1  6.5.1  7.8.6
Network			
No LAN connection can be established	Incorrect IP address is set (fix IP)	Use dynamic IP address by enabling DHCP option.	 4.1.2  5.9.2  6.4.2  7.7.2
			Restore the factory default settings (with fix IP).
	IP address conflict	Check the IP address of the other devices, too.	

Symptom	Root cause	Action	Refer to
Miscellaneous			
Function button is out of operation	Function button is locked	Unlock the button	 5.9.1
Error messages received always	Different protocol is set	Check the port protocol settings (LW2 / LW3) and use the proper protocol commands.	 5.7.1
			 6.5.4
			 6.5.5
			 7.8.1

9.2. How to Speed Up the Troubleshooting Process

Lightware's technical support team is always working hard to provide the fastest support possible. Our team's response time is one of the best in the industry and in the toughest of cases we can directly consult with the hardware or software engineer who designed the product to get the information from the most reliable source.

However, the troubleshooting process can be even faster... with your help.

There are certain pieces of information that push us in the right direction to finding the root cause of the problem. If we receive most of this information in the first e-mail or it is gathered at the time when you call us, then there is a pretty high chance that we will be able to respond with the final solution right away.

This information is the following:

- Schematic (a pdf version is preferred, but a hand drawing is sufficient).
- Serial number(s) of the device(s) (it is either printed somewhere on the box or you can query it in the Device Controller software or on the built-in website).
- Firmware versions of the devices (please note that there may be multiple CPUs or controllers in the device and we need to know all of their firmware versions, a screenshot is the best option).
- Cable lengths and types (in our experience, it's usually the cable).
- Patch panels, gender changers or anything else in the signal path that can affect the transmission.
- Signal type (resolution, refresh rate, color space, deep color).
- Emulated EDID(s) (please save them as file and send them to us).
- Actions to take in order to re-create the problem (if we cannot reproduce the problem, it is hard for us to find the cause).
- Photo or video about the problem ('image noise' can mean many different things, it's better if we see it too).
- Error logs from the Device Controller software.
- In the case of Event Manager issue the event file and/or backup file from the Device Controller software.

The more of the above information you can give us the better. Please send these information to the Lightware Support Team (support@lightware.com) to speed up the troubleshooting process.

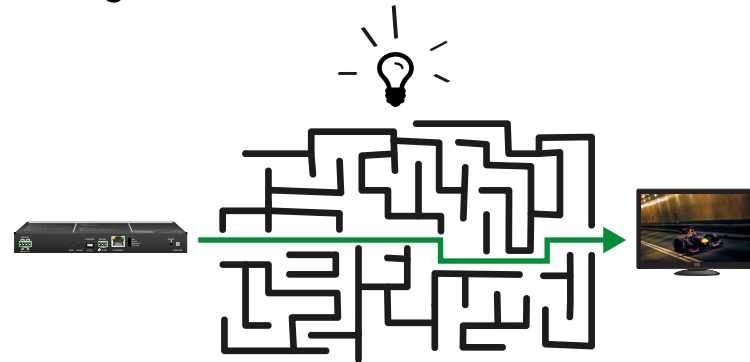

10

Technologies

The following sections contain descriptions and useful technical information how the devices work in the background. The content is based on experiences and cases we met in the practice. These sections help to understand features and technical standards like the followings:

- ▶ EDID MANAGEMENT
- ▶ HDCP MANAGEMENT
- ▶ PIXEL ACCURATE RECLOCKING

10.1. EDID Management

10.1.1. Understanding the EDID

The Extended Display Identification Data (EDID) is the passport of display devices (monitors, TV sets, projectors). It contains information about the capabilities of the display, such as supported resolutions, refresh rates (these are called Detailed Timings), the type and manufacturer of the display device, etc.

After connecting a source to a display (DVI, HDMI, DP), the source reads out the EDID to determine the resolution and refresh rate of the image to be transmitted.

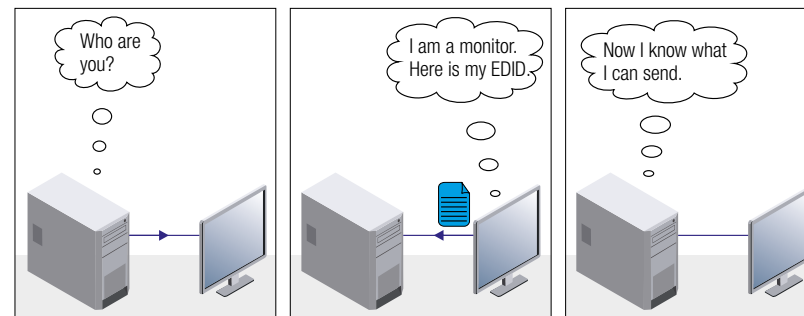

EDID Communication

Most DVI computer displays have 128-byte long EDID structure. However, Digital Televisions and HDMI capable displays may have another 128 bytes, which is called E-EDID and defined by CEA (Consumer Electronics Association). This extension contains information about additional Detailed Timings, audio capabilities, speaker allocation and HDMI capabilities. It is important to know that all HDMI capable devices must have CEA extension, but not all devices with CEA extension are HDMI capable.

Common Problems Related to EDID

Problem: “My system consists of the following: a computer, a Lightware device, a WUXGA (1920x1200) LCD monitor, and an SXGA (1280x1024) projector. I would like to see the same image on the monitor and the projector. What EDID should I choose on the Lightware device?”

Solution: If you want to see the image on both displays, you need to select the resolution of the smaller display (in this case SXGA), otherwise the smaller display may not show the higher resolution image.

Problem: “I have changed to a different EDID on an input port of the Lightware device to have a different resolution but nothing happens.”

Solution: Some graphics cards and video sources read out the EDID only after power-up and later they do not sense that EDID has been changed. You need to restart your source to make it read out the EDID again.

10.1.2. Advanced EDID Management

Each DVI sink (e.g. monitors, projectors, plasma displays, etc...) must support the EDID data structure. Source BIOS and operating systems are likely to query the sink using DDC2B protocol to determine what pixel formats and interface are supported. DVI standard uses EDID data structure to identify the monitor type and capabilities. Most DVI sources (VGA cards, set top boxes, etc.) will output DVI signal after accepting the connected sink's EDID information. In the case of EDID readout failure or missing EDID, the source will not output DVI video signal.

Lightware devices provide the Advanced EDID Management function that helps system integration. The built-in EDID Router can store and emulate factory pre-programmed- and User programmable EDIDs. The EDID of the attached monitors or projectors for each output are stored in a non-volatile memory. This way the EDID of a monitor is available when the monitor is unplugged or switched off.

Any EDID can be emulated on any input. An emulated EDID can be copied from the EDID router's memory (static EDID emulation), or from the last attached monitor's memory (dynamic EDID emulation). For example, the Lightware device can be set up to emulate a sink device, which is connected to one of the outputs. In this case, the EDID automatically changes, if the monitor is replaced with another display device (as long as it has a valid EDID).

EDID is independently programmable for all inputs without affecting each other. All inputs have their own EDID circuit.

INFO: The user is not required to disconnect the video cable to change an EDID as opposed to other manufacturer's products. EDID can be changed even if a source is connected to the input and powered ON.

INFO: When EDID has been changed, the router toggles the HOTPLUG signal for 2 seconds. Some sources do not sense this signal. In such cases, the source device must be restarted or powered OFF and ON again.

10.2. HDCP Management

Lightware Visual Engineering is a legal HDCP adopter. Several functions have been developed which helps to solve HDCP related problems. Complex AV systems often have both HDCP and non-HDCP components. The receiver allows transmitting HDCP encrypted and unencrypted signals. The devices will be still HDCP compliant as they will never output an encrypted signal to a non-HDCP compliant display device. If an encrypted signal is switched to a non-compliant output, a red screen alert or muted screen will appear.

10.2.1. Protected and Unprotected Content

Many video sources send HDCP protected signal if they detect that the sink is HDCP capable – even if the content is not copyrighted. This can cause trouble if an HDCP capable device is connected between the source and the display. In this case, the content cannot be viewed on non-HDCP capable displays and interfaces like event controllers. Rental and staging technicians often complain about certain laptops, which are always sending HDCP encrypted signals if the receiver device (display, matrix router, etc.) reports HDCP compliancy. However, HDCP encryption is not required all the time e.g. computer desktop image, certain laptops still do that.

To avoid unnecessary HDCP encryption, Lightware introduced the HDCP enabling/disabling function: the HDCP capability can be disabled in the Lightware device. If HDCP is disabled, the connected source will detect that the sink is not HDCP capable, and turn off authentication.

10.2.2. Disable Unnecessary Encryption

HDCP Compliant Sink

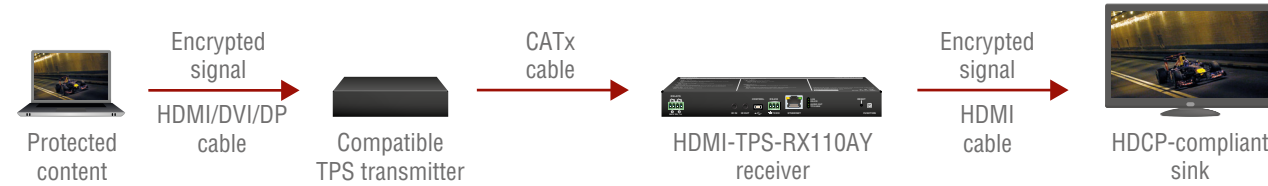

All the devices are HDCP-compliant, no manual setting is required, both protected and unprotected contents are transmitted and displayed on the sink.

Not HDCP-compliant Sink 1.

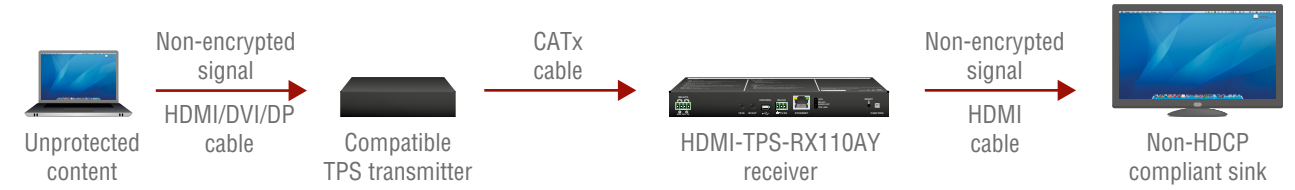

Non-HDCP compliant sink is connected to the receiver. Some sources (e.g. computers) always send HDCP encrypted signals if the receiver device reports HDCP compliancy, however, HDCP encryption is not required all the time (e.g. computer desktop image). If HDCP is enabled in the receiver, the image will not be displayed on the sink.

Setting the HDCP parameter to Auto on the output port and disable HDCP on the input port, the transmitted signal will not be encrypted if the content is not protected. Thus, non-HDCP compliant sinks will display non-encrypted signal.

Not HDCP-compliant Sink 2.

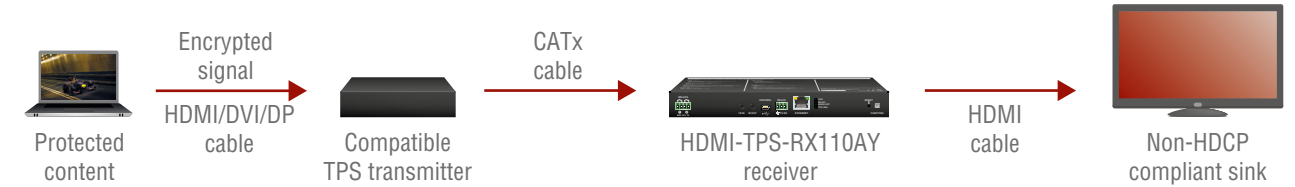

The layout is the same as in the previous case: non-HDCP compliant display device is connected to the receiver but the source would send protected content with encryption. If HDCP is enabled on the input port of the receiver, the source will send encrypted signal. The sink is not HDCP compliant, thus, it will not display the video signal (but blank/red/muted/etc. screen). If HDCP is disabled on the input port of the receiver, the source will not send the signal. The solution is to replace the display device to an HDCP-capable one.

10.3. Pixel Accurate Reclocking

Signal reclocking is an essential important procedure in digital signal transmission. After passing the reclocking circuit, the signal becomes stable, jitter-free, and can be transmitted over more equipment like processors, or event controllers. Without reclocking, sparkles, noise, and jaggies appear on the image.

Lightware's sophisticated Pixel Accurate Reclocking technology fixes more problems than general TMDS reclocking. It removes not only intra-pair skew but inter-pair skew as well. The Pixel Accurate Reclocking circuit eliminates the following errors:

Intra-pair skew

Skew between the + and - wires within a differential wire pair (e.g. Data2- and Data2+). It's caused by different wire lengths or slightly different wire construction (impedance mismatch) in DVI cable. It results in jitter.

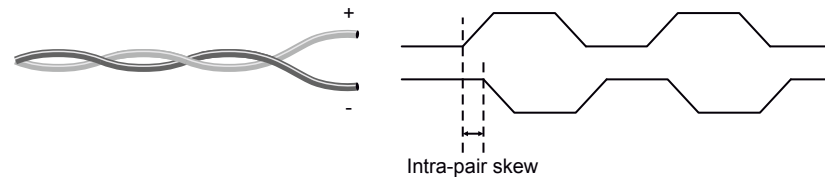

Inter-pair skew

Skew between two differential wire pairs in a cable. It is caused by different wire pair lengths or different number of twists in the DVI cable. Too much inter-pair skew results color shift in the picture or sync loss.

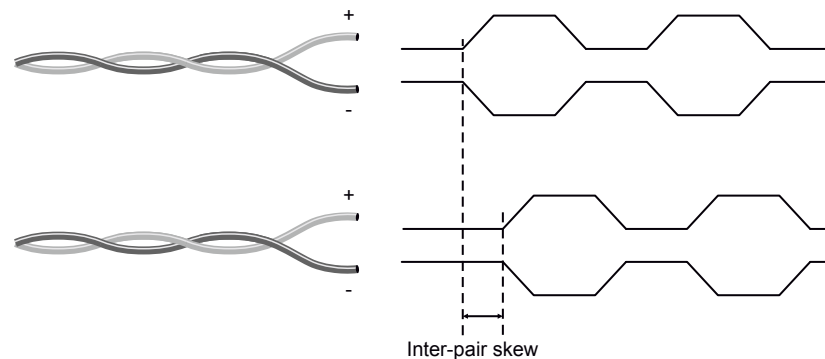

Jitter

Signal instability in the time domain. The time difference between two signal transitions should be a fixed value, but noise and other effects cause variations.

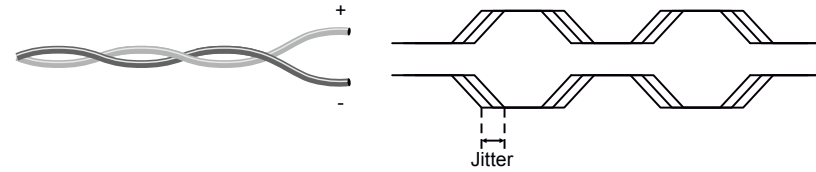

Noise

Electromagnetic interference between other electronic devices such as mobile phones, motors, etc. and the DVI cable are coupled onto the signal. Too much noise results in increased jitter.

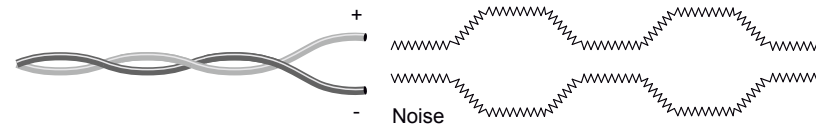

11

Appendix

Tables, drawings, guides, and technical details as follows:

- ▶ [SPECIFICATION](#)
- ▶ [INPUT/OUTPUT PORT NUMBERING](#)
- ▶ [CONTENT OF BACKUP FILE](#)
- ▶ [FACTORY DEFAULT SETTINGS](#)
- ▶ [MAXIMUM EXTENSION DISTANCES](#)
- ▶ [MECHANICAL DRAWINGS](#)
- ▶ [CABLE WIRING GUIDE](#)
- ▶ [FACTORY EDID LIST](#)
- ▶ [RELEASE NOTES OF THE FIRMWARE PACKAGES](#)
- ▶ [FURTHER INFORMATION](#)

11.1. Specification

General

Compliance	CE
EMC compliance (emission)	IEC/EN 55032:2015
EMC compliance (immunity)	IEC/EN 55024:2011
Warranty	3 years
Cooling	Passive
Operating temperature	0 to +50°C (+32 to +122°F)
Operating humidity	10% to 90%, non-condensing

Power

Power supply	External power adaptor or PoE remote powering
Power adaptor	In 100-240 V AC 50/60 Hz, Out 12V DC, 2 A
Power connector	Locking DC connector (2.1 mm pin)
Power over TPS	DC 48V, 1A (IEEE 802.3af)
Power consumption	10 W (typ)

Enclosure

Rack mountable	Yes
Material	1 mm steel
Dimensions in mm	221W x 100.4D x 26H
Dimensions in inch	8.7 W x 3.95 D x 1.02 H
Weight	607 g

Audio/Video Ports

HDCP compliant	Yes, HDCP 1.4
----------------------	---------------

TPS Input Port

TPS port connector type	RJ45 connector
Power over Ethernet (PoE)	Yes (IEEE 802.3af)
Compliance	HDBaseT™
Transferred signals (TPS)	Video, Audio, RS-232, Infrared, Ethernet
Max. video resolutions	1920x1080@120 Hz, 24 bit
.....	1600x1200@60 Hz, 36 bit
.....	3840x2160@30 Hz, 24 bit

Audio formats	8 channel PCM
.....	Dolby TrueHD
.....	DTS-HD Master Audio 7.1
Reclocking	Pixel Accurate Reclocking
HDCP compliant	Yes

HDMI Output Port

HDMI port connector type	19-pole HDMI Type A receptacle
Standard	DVI 1.0, HDMI 1.4
Max. video resolutions	1920x1080@120 Hz, 24 bit
.....	1600x1200@60 Hz, 36 bit
.....	3840x2160@30 Hz, 24 bit
Audio formats	8 channel PCM
.....	Dolby TrueHD
.....	DTS-HD Master Audio 7.1
Reclocking	Pixel Accurate Reclocking
HDCP compliant	Yes

Analog Audio Output Port

Audio port connector	5-pole Phoenix connector
Signal transmission	Balanced and unbalanced audio
Volume	-95.62 – 0 dB

Control Ports

RS-232 Control

Serial port connector	3-pole Phoenix connector
Available Baud rates	between 4800 and 115200
Available Data bits	8 or 9
Available Parity	None / Odd / Even
Available Stop bits	1 / 1.5 / 2

USB Control

USB connector	USB mini B type
USB 2.0 compliance	Yes

Infrared Control

Number of IR ports 2 (1x RX, 1x TX)
 Connector type..... 3.5mm TRS (approx. 1/8" jack)
 Connector type..... Locking RJ45
 Ethernet data rate 10/100Base-T, full duplex with autodetect
 Power over Ethernet (PoE) Not supported

Relay Port

Port connector 4-pole Phoenix connector
 Number of relays 2
 Type Normally open contacts
 Maximum ratings..... 30 V, 1 A, AC/DC
 Default connection state Open

11.2. Input/Output Port Numbering

The following table contains the input and output ports with their ID numbers which shall be used when protocol command sending or in Lightware Device Controller.

Audio/Video Ports

Port name	Video port nr.		Emulated EDID memory	Audio port nr.	
	LW2	LW3		LW2	LW3
TPS Link in	1	I1	E1	1	I1
HDMI out	1	O1	-	1	O1
Audio out	-	-	-	2	O2

RS-232 Ports

Port name	Port nr. (LW2 / LW3)
Local	P1
TPS link	P2

Infrared Ports

Port name	Port nr. (LW3)
Local IR input	S1
Local IR output	D1
TPS link input	S2
TPS link output	D2

11.3. Content of Backup File

The backup file contains numerous settings and parameters saved from the device. When the file is uploaded to a device, the followings will be overwritten:

TPS input port
Video port name, Audio port name, HDCP setting
Ethernet port name, Ethernet port status (enable / disable)
Remote port name, Remote port status (enable / disable)
Analog audio output port
Port name, Volume, Balance
HDMI output port
Port name, HDCP mode, HDMI mode, Power +5V mode
Test pattern mode, clock source, and type
Audio port name, Audio output enabled, S/PDIF mode
Port parameters
Mute video ports
Mute audio ports, Lock audio ports
Local and TPS serial port
RS-232 mode, Control protocol, Baud rate, Data bits, Stop bits, Parity
Port name and CI (Command Injection) port number
Local and TPS IR port
Port status (enable / disable), Code length, Repetition code, Enable modulation
Input port name, Output port name
CI status (enable / disable), CI port number
USB port
Port name, Port status (enable / disable)
Relay ports
Port name, Connection state
Network settings
DHCP status (enable / disable)
Static IP address, Network mask, Gateway address
Further settings
User EDID data (U1-U15)
Event manager: settings of all Events (E1-E100)

11.4. Factory Default Settings

Parameter	Setting/Value
Video port settings	
TPS mode	Auto
HDCP	Enabled
Test pattern mode	Disabled
Test pattern clock source	480p
Test pattern	Bar
Output HDMI mode	Auto
Output HDCP mode	Auto
Power 5V mode	Always on
Analog audio port settings	
Volume	0.00 dB (100%)
Balance	0 (center)
Network settings	
IP address	192.168.0.100
Subnet mask	255.255.255.0
Static gateway	192.168.0.1
DHCP	Disabled
Port numbers (LW2 / LW3 / HTTP)	10001 / 6107 / 80
TPS Ethernet status	Enabled
Relay port settings	
Connection state	Open
RS-232 settings	
Control protocol	LW2
Baud rate	57600
Databits	8
Parity	No
Stopbits	1
Operation mode (Link and Local)	Pass-through
Command injection port nr. (Local / TPS)	8001 / 8002
IR port settings	
Command injection status	Enabled
Comm. inj. input port nr. (Local / TPS)	9001 / 9002
Comm. inj. output port nr. (Local / TPS)	9003 / 9004

11.5. Maximum Extension Distances

Resolution	Pixel clock rate	Cable lengths (Auto / Longreach TPS mode)		
		CAT5e AWG24	CAT7 AWG26**	CAT7 AWG23
1024x768@60Hz	65 MHz	100 m / 130 m*	90 m / 120 m*	120 m / 170 m*
1280x720p@60Hz	73.8 MHz	100 m / 130 m*	90 m / 120 m*	120 m / 170 m*
1920x1080p@60Hz / 24bpp	148.5 MHz	100 m / 130 m*	90 m / 120 m*	120 m / 170 m*
1920x1200@60Hz	152.9 MHz	100 m / NA	90 m / NA	120 m / NA
1600x1200@60Hz	162 MHz	100 m / NA	90 m / NA	120 m / NA
1920x1080@60Hz / 36bpp	223.6 MHz	70 m / NA	70 m / NA	100 m / NA
3840x2160@30Hz UHD	297 MHz	70 m / NA	70 m / NA	100 m / NA
4096x2160@30Hz 4K	297 MHz	70 m / NA	70 m / NA	100 m / NA

* With Long reach operation mode which supports pixel clock frequencies up to 148.5 MHz.

** When remote powering is used with AWG26 cables, distances are 20% shorter.

11.6. Mechanical Drawings

The following drawings present the physical dimensions of the receiver. Dimensions are in mm.

Bottom View

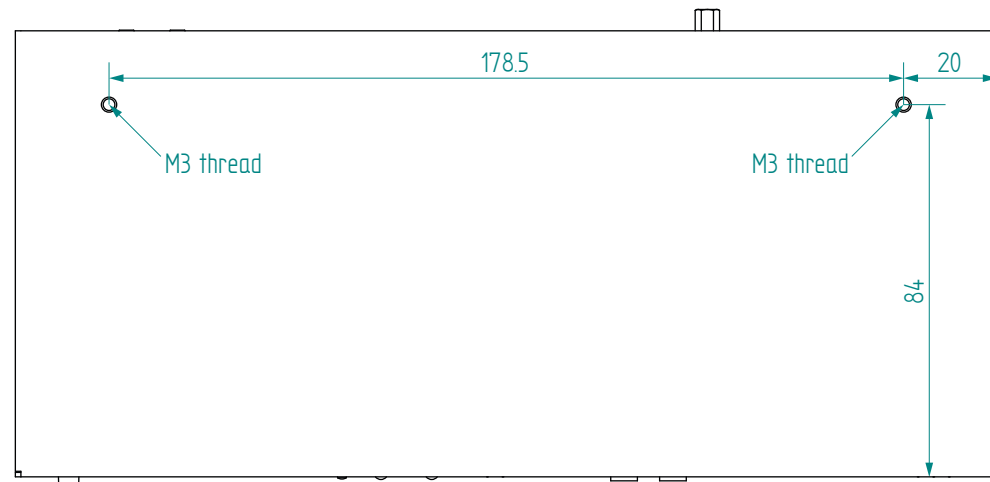

Front View

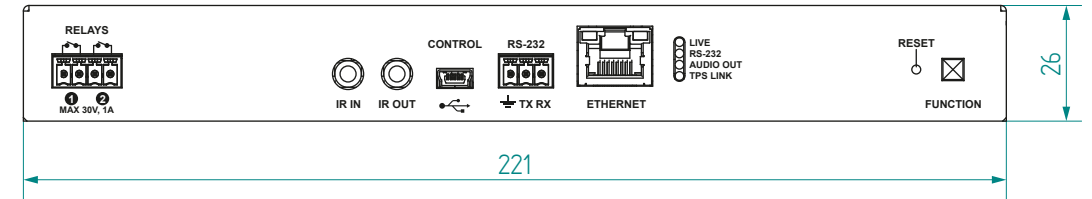

Top View

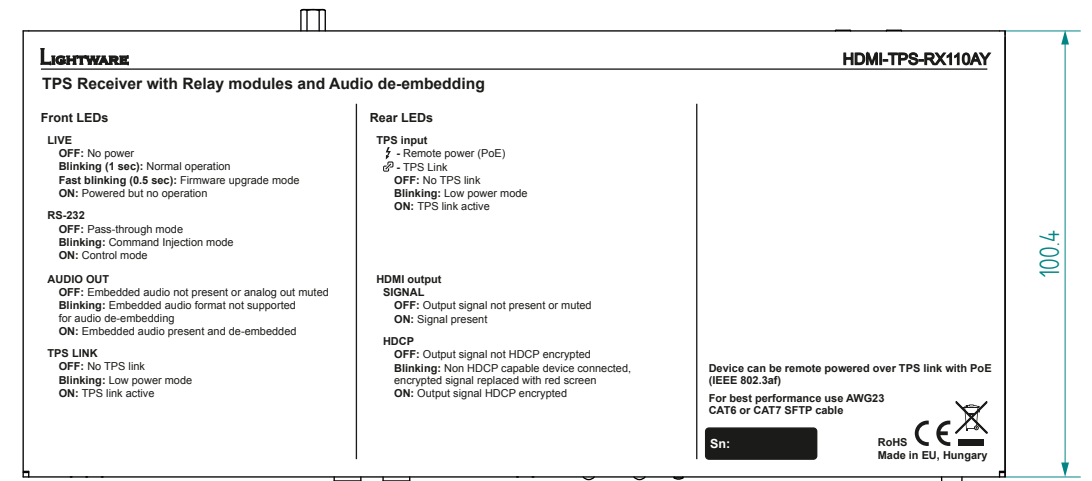

Rear View



Side View

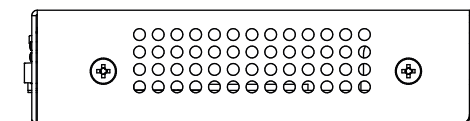

11.7. Cable Wiring Guide

11.7.1. Cable Wiring Guide for Serial Data Transmission

The receivers are built with 3-pole Phoenix connector. See below the two examples of the most common assembling cases.

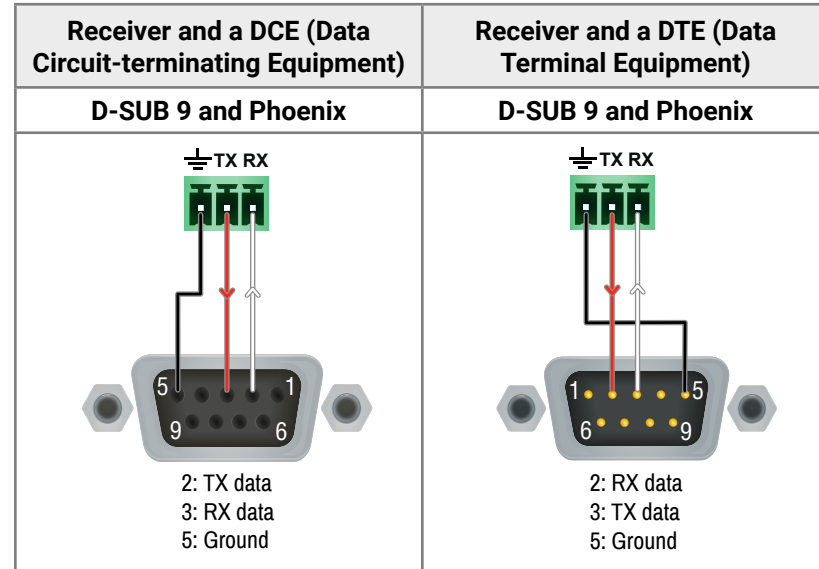

11.7.2. Audio Cable Wiring Guide

Inputs and outputs of audio devices are symmetric or asymmetric. The main advantage of the symmetric lines is the better protection against the noise therefore, they are widely used in the professional audio industry. Symmetric audio is most often referred to as balanced audio, as opposed to asymmetric, which is referred to as unbalanced audio. Lightware products are usually built with 5-pole Phoenix connectors so we would like to help users assembling their own audio cables. See the most common cases below.

ATTENTION! Symmetric and asymmetric lines can be linked with passive accessories (e.g. special cables), but in this case half of the line level is lost.

ATTENTION! There are numerous types of regularly used connector and cable types to connect audio devices. Please always make sure that a connector or cable fits your system before use.

ATTENTION! Never join the phase-inverted (negative, cold or -) poles (either right and left) to the ground or to each other on the output side, as this can damage the unit.

INFO: Use a galvanic isolation in case of a ground loop.

From Unbalanced Output to Balanced Input

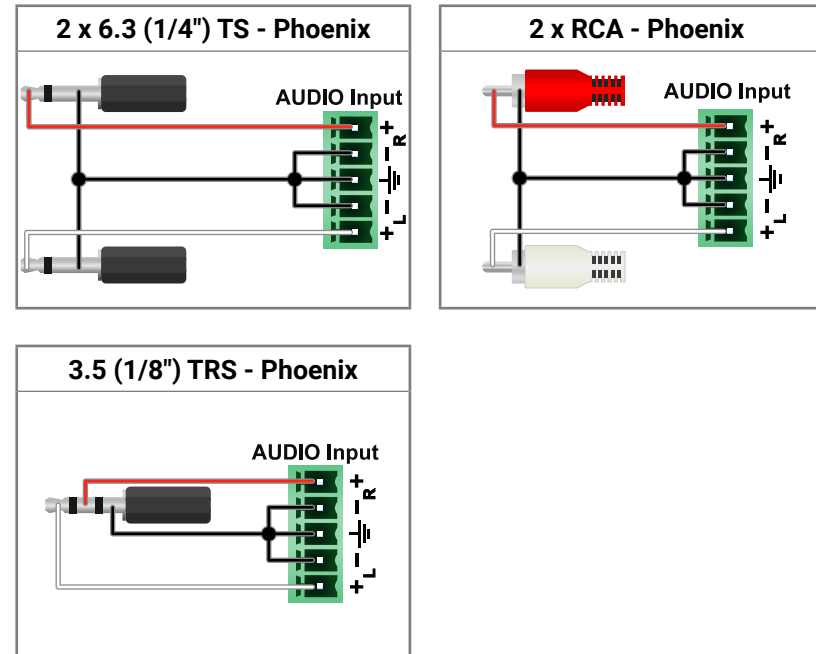

From Balanced Output to Unbalanced Input

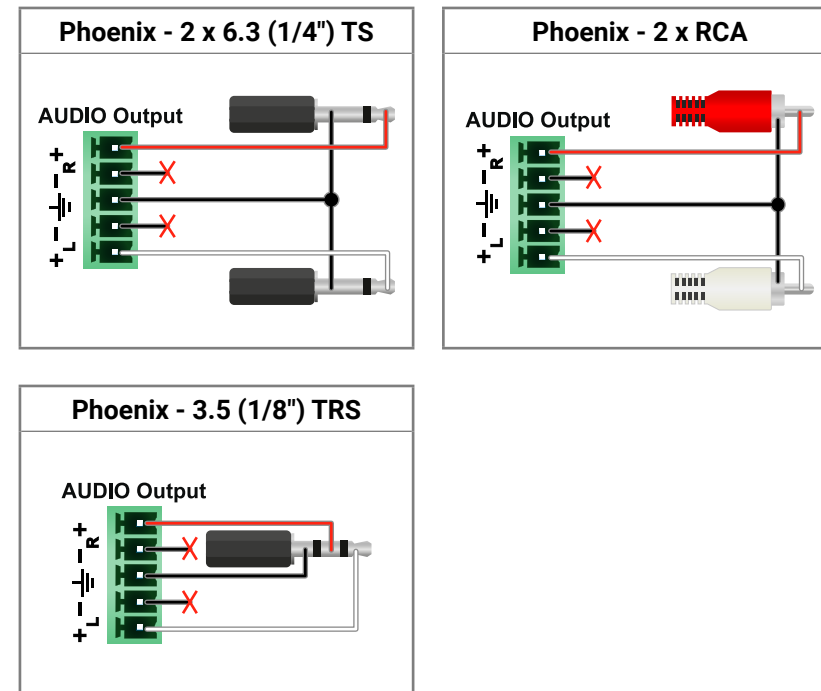

From Balanced Output to Balanced Input

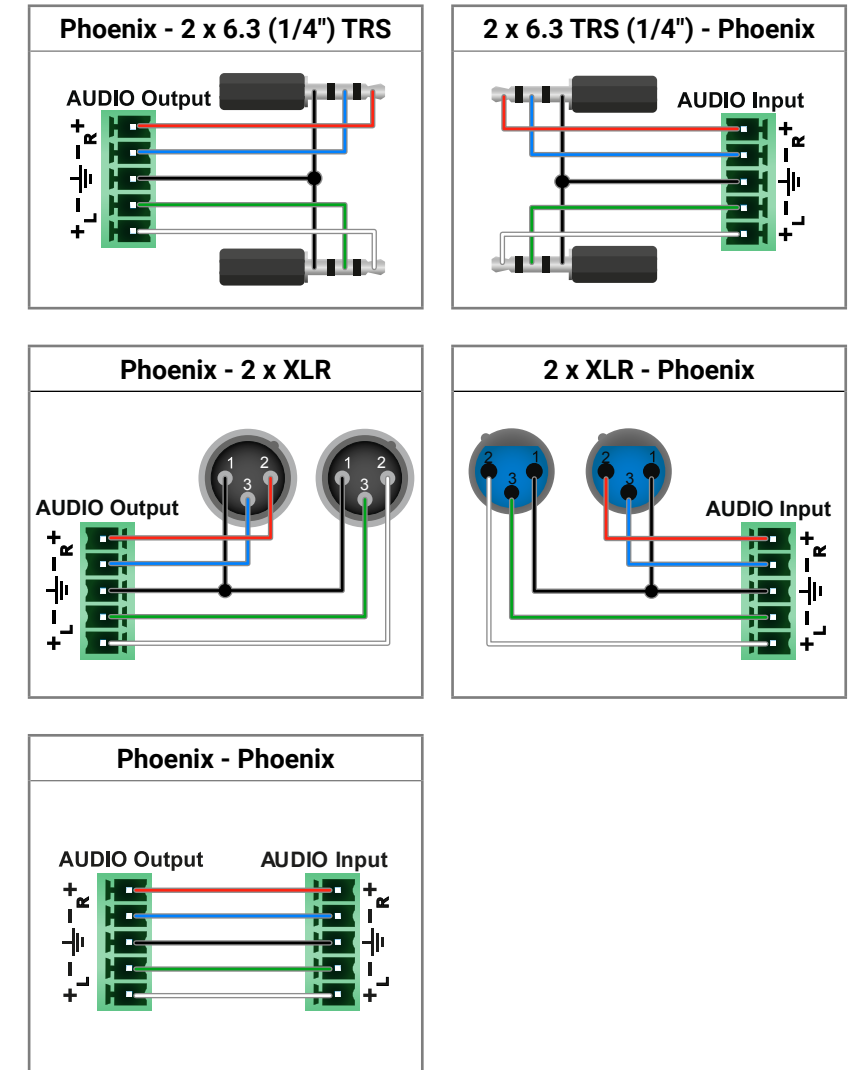

For more information about the cable wiring see the **Cable Wiring Guide** on our website <https://lightware.com/support/guides-and-white-papers>.

11.8. Factory EDID List

Mem.	Resolution				Type	Mem.	Resolution				Type
F1	640 x	480	@ 60.00	Hz	D	F34	720 x	576	@ 50.00	Hz	H
F2	848 x	480	@ 60.00	Hz	D	F35	1280 x	720	@ 50.00	Hz	H
F3	800 x	600	@ 60.32	Hz	D	F36	1280 x	720	@ 60.00	Hz	H
F4	1024 x	768	@ 60.00	Hz	D	F37	1920 x	1080i	@ 50.04	Hz	H
F5	1280 x	768	@ 50.00	Hz	D	F38	1920 x	1080i	@ 50.00	Hz	H
F6	1280 x	768	@ 59.94	Hz	D	F39	1920 x	1080i	@ 60.05	Hz	H
F7	1280 x	768	@ 75.00	Hz	D	F40	1920 x	1080i	@ 60.05	Hz	H
F8	1360 x	768	@ 60.02	Hz	D	F41	1920 x	1080	@ 24.00	Hz	H
F9	1280 x	1024	@ 50.00	Hz	D	F42	1920 x	1080	@ 25.00	Hz	H
F10	1280 x	1024	@ 60.02	Hz	D	F43	1920 x	1080	@ 30.00	Hz	H
F11	1280 x	1024	@ 75.02	Hz	D	F44	1920 x	1080	@ 50.00	Hz	H
F12	1400 x	1050	@ 50.00	Hz	D	F45	1920 x	1080	@ 60.00	Hz	H
F13	1400 x	1050	@ 60.00	Hz	D	F46	1920 x	1080	@ 60.00	Hz	H
F14	1400 x	1050	@ 75.00	Hz	D	F47	Universal_HDMI_PCM			H	
F15	1680 x	1050	@ 60.00	Hz	D	F48	Universal_HDMI_ALL			H	
F16	1920 x	1080	@ 50.00	Hz	D	F49	Universal_HDMI_DC			H	
F17	1920 x	1080	@ 60.00	Hz	D	F50-F89	Reserved				
F18	2048 x	1080	@ 50.00	Hz	D	F90	1920 x	2160	@ 59.99	Hz	D
F19	2048 x	1080	@ 60.00	Hz	D	F91	1024 x	2400	@ 60.01	Hz	D
F20	1600 x	1200	@ 50.00	Hz	D	F92-F93	Reserved				
F21	1600 x	1200	@ 60.00	Hz	D	F94	2048 x	1536	@ 60.00	Hz	D
F22	1920 x	1200	@ 50.00	Hz	D	F95	Reserved				
F23	1920 x	1200	@ 59.56	Hz	D	F96	2560 x	1600	@ 59.86	Hz	D
F24	2048 x	1200	@ 59.96	Hz	D	F97	3840 x	2400	@ 24.00	Hz	D
F25-F28	Reserved					F98	1280 x	720	@ 60.00	Hz	H3D
F29	Universal_DVI			D		F99	1920 x	1080	@ 60.00	Hz	H3D
F30	1440 x	480i	@ 60.05	Hz	H	F100	1024 x	768	@ 60.00	Hz	H
F31	1440 x	576i	@ 50.08	Hz	H	F101	1280 x	1024	@ 50.00	Hz	H
F32	640 x	480	@ 59.95	Hz	H	F102	1280 x	1024	@ 60.02	Hz	H
F33	720 x	480	@ 59.94	Hz	H	F103	1280 x	1024	@ 75.02	Hz	H

Mem.	Resolution				Type	Mem.	Resolution				Type
F104	1600 x	1200	@ 50.00	Hz	H	F111	3840 x	2160	@ 25.00	Hz	H
F105	1600 x	1200	@ 60.00	Hz	H	F112	3840 x	2160	@ 30.00	Hz	H
F106	1920 x	1200	@ 59.56	Hz	H	F113-F117	Reserved				
F107	2560 x	1440	@ 59.95	Hz	H	F118	Universal_4K_PCM			H4K	
F108	2560 x	1600	@ 59.86	Hz	H	F119	Universal_4K_ALL			H4K	
F109	3840 x	2400	@ 24.00	Hz	H	F120	3840 x	2160	@ 60.00	Hz	H4K
F110	3840 x	2160	@ 24.00	Hz	H						

Legend

Type	Description
D	DVI EDID
H	HDMI EDID
A	Analog EDID
DL	Dual-Link DVI EDID
H3D	HDMI EDID with 3D support
H4K	HDMI EDID with 4K resolution support

11.9. Release Notes of the Firmware Packages

v1.3.1b6

Release date: 2019-09-25

New feature:

- Improved the Audio Crosspoint functionality
- Added 'Forced button lock' function to lock buttons via protocol command
- RS232 Minimal Recognizer for Cisco compatibility (Cisco Login)
- sendProntoHex over TPS
- Compatible for LDU2 only! Use LDU2 v2.0.0 or later for the upgrade!
- Added 'Disable default button function' option to support button customization in Event Manager
- Added 'Dark mode' function to turn off front panel LEDs
- Modified RS-232 modes to support SendMessage in Control mode
- Firmware platform library updated
- CEC - sendCEC command (e.g. turn on the TV with Event Actions) for HDMI-TPS-RX110AY-Plus only!
- Sending IR codes (SendProntoHex e.g. send max. 200 Byte IR code with Event Actions) for HDMI-TPS-RX110AY-Plus only!

v1.3.0b1

Release date: 2018-09-25

New feature:

- Added 'Forced button lock' function to lock buttons via protocol command

v1.1.1b2

Release date: 2018-04-21

New feature:

- Improved the Audio Crosspoint functionality

v1.1.0b3

Release date: 2018-04-09

New feature:

- #TBD

11.10. Further Information

Limited Warranty Statement

1. Lightware Visual Engineering LLC (Lightware) warrants to all trade and end user customers that any Lightware product purchased will be free from manufacturing defects in both material and workmanship for three (3) years from purchase unless stated otherwise below. The warranty period will begin on the latest possible date where proof of purchase/delivery can be provided by the customer. In the event that no proof can be provided (empty 'Date of purchase' field or a copy of invoice), the warranty period will begin from the point of delivery from Lightware.

1.1. 25G and MODEX product series will be subject to a seven (7) year warranty period under the same terms as outlined in this document.

1.2. If during the first three (3) months of purchase, the customer is unhappy with any aspect of a Lightware product, Lightware will accept a return for full credit.

1.3. Any product that fails in the first six (6) months of the warranty period will automatically be eligible for replacement and advanced replacement where available. Any replacements provided will be warranted for the remainder of the original unit's warranty period.

1.4. Product failures from six (6) months to the end of the warranty period will either be repaired or replaced at the discretion of Lightware. If Lightware chooses to replace the product then the replacement will be warranted for the remainder of the original unit's warranty period.

2. The above-stated warranty and procedures will not apply to any product that has been:

2.1. Modified, repaired or altered by anyone other than a certified Lightware engineer unless expressly agreed beforehand.

2.2. Used in any application other than that for which it was intended.

2.3. Subjected to any mechanical or electrical abuse or accidental damage.

2.4. Any costs incurred for repair/replacement of goods that fall into the above categories (2.1., 2.2., 2.3.) will be borne by the customer at a pre-agreed figure.

3. All products to be returned to Lightware require a return material authorization number (RMA) prior to shipment and this number must be clearly marked on the box. If an RMA number is not obtained or is not clearly marked on the box, Lightware will refuse the shipment.

3.1. The customer will be responsible for in-bound and Lightware will be responsible for out-bound shipping costs.

3.2. Newly repaired or replaced products will be warranted to the end of the originally purchased products warranty period.

Document Revision History

Rev.	Release date	Changes	Editor
1.0	22-12-2016	Initial version	Tamas Forgacs
1.1	06-02-2017	Added detailed audio function description in LW3 programmer's reference, added RS-232 commands in LW2 programmer's reference	Tamas Forgacs
2.0	19-09-2017	New document format, updated LW3 prog. ref. chapter	Tamas Forgacs
2.1	04-12-2017	Major updates for firmware v1.2.0, updated Troubleshooting chapter	Tamas Forgacs
2.2	31-10-2018	1080p120Hz signal support info added	Judit Barsony
2.3	08-10-2019	Added supplement in connection with HDMI-TPS-RX110AY-Plus model, implemented hashtag keywords for the optimized information search	Tamas Forgacs

Contact Us

sales@lightware.com

+36 1 255 3800

support@lightware.com

+36 1 255 3810

Lightware Visual Engineering LLC.

Peterdy 15, Budapest H-1071, Hungary

www.lightware.com

©2019 Lightware Visual Engineering. All rights reserved. All trademarks mentioned are the property of their respective owners. Specifications subject to change without notice.